

USB-PD TYPE-C RECEPTACLE

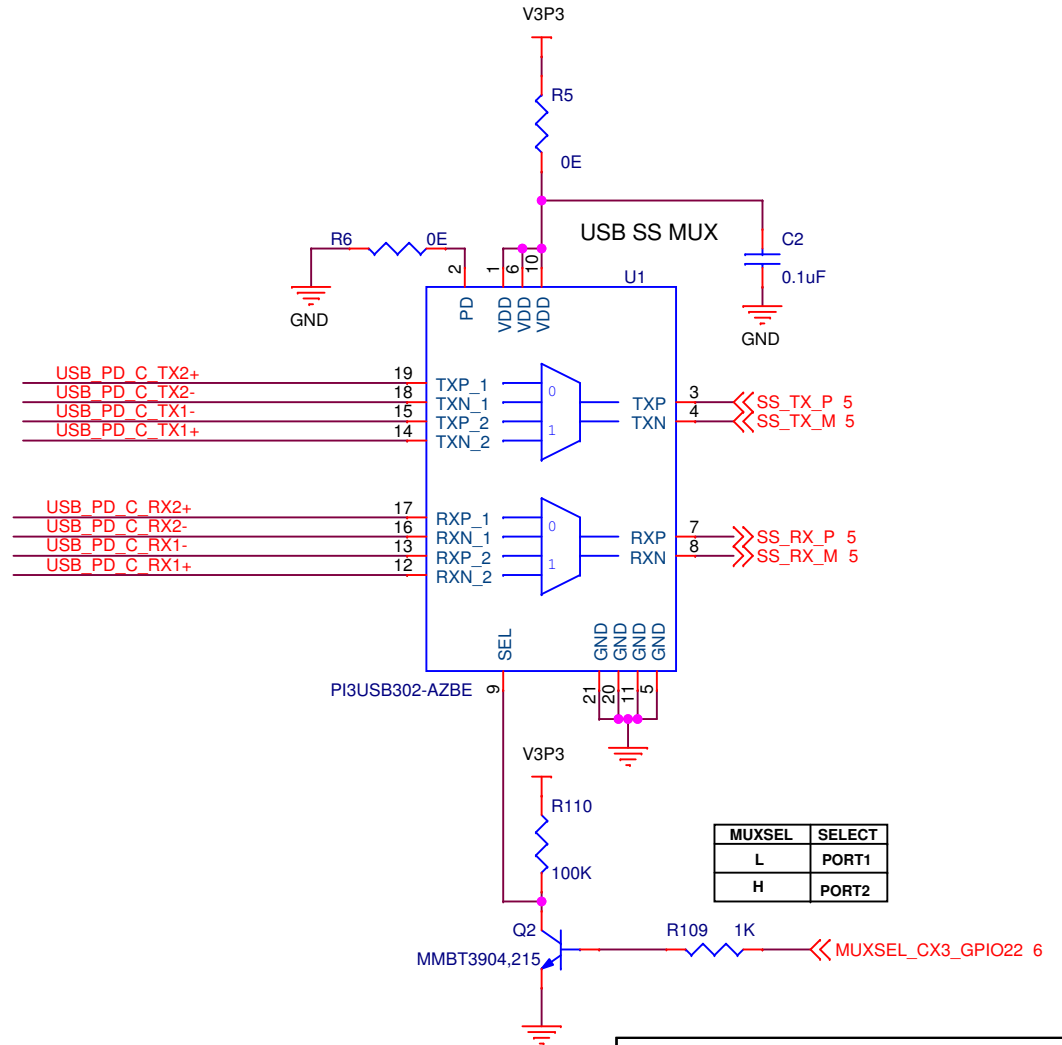
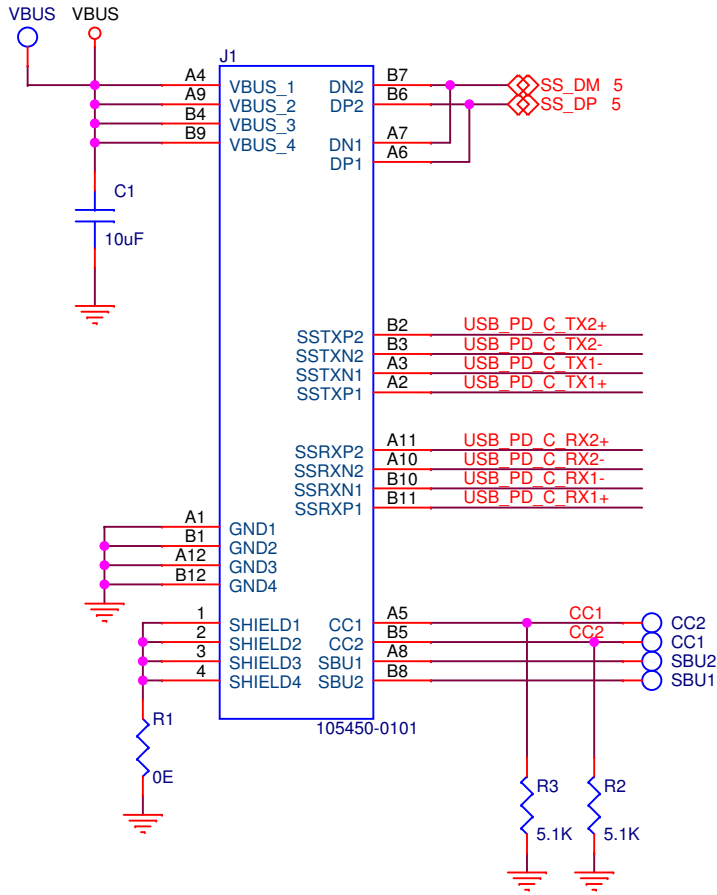

Project Name
TANIA- Cypress® CX3™ Socionext® ISP Dual AF CAMERA RDK

Size A4	Page Title USB-C CONNECTOR AND MUX	Rev 1.0
------------	---------------------------------------	------------

Date: Tuesday, October 03, 2017 | Sheet 2 of 14

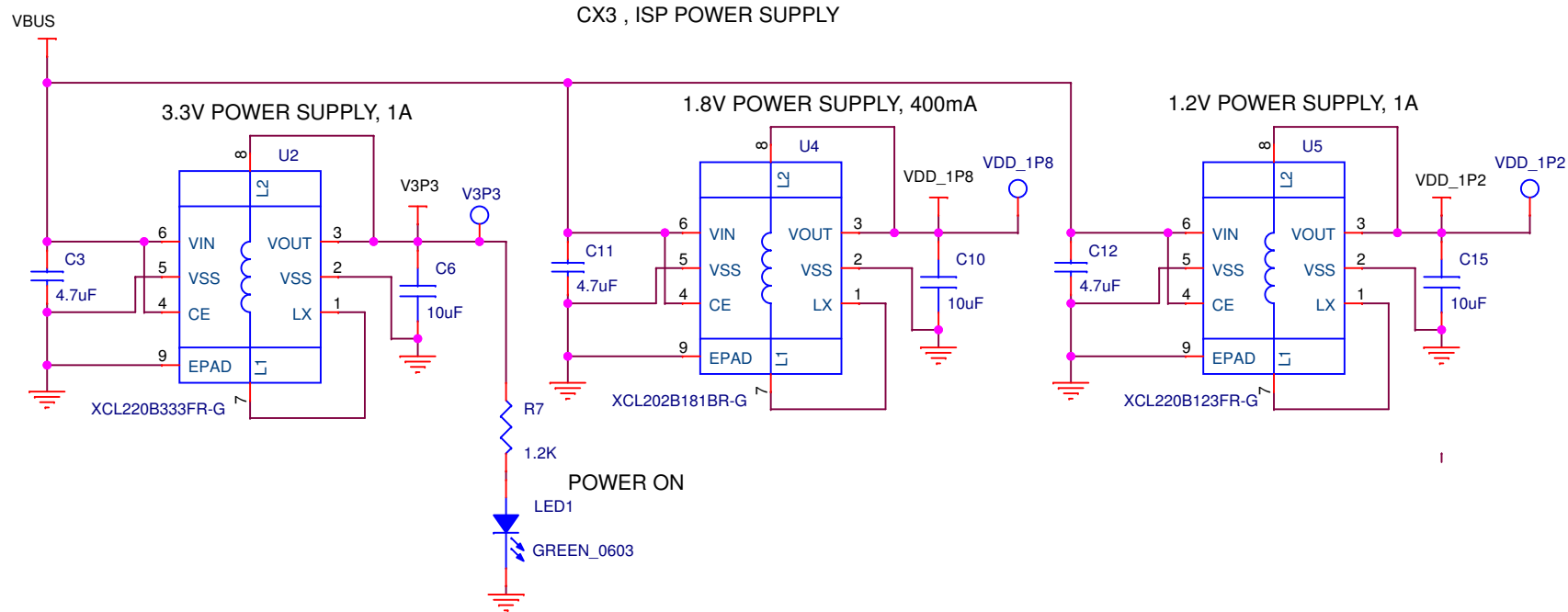



e-con Systems
Your Product Development Partner

Project Name		
TANIA- Cypress® CX3™ Socionext® ISP Dual AF CAMERA RDK		
Size A4	Page Title CX3, ISP CORE & IO POWER SUPPLY	Rev 1.0
Date: Tuesday, October 03, 2017		Sheet 3 of 14

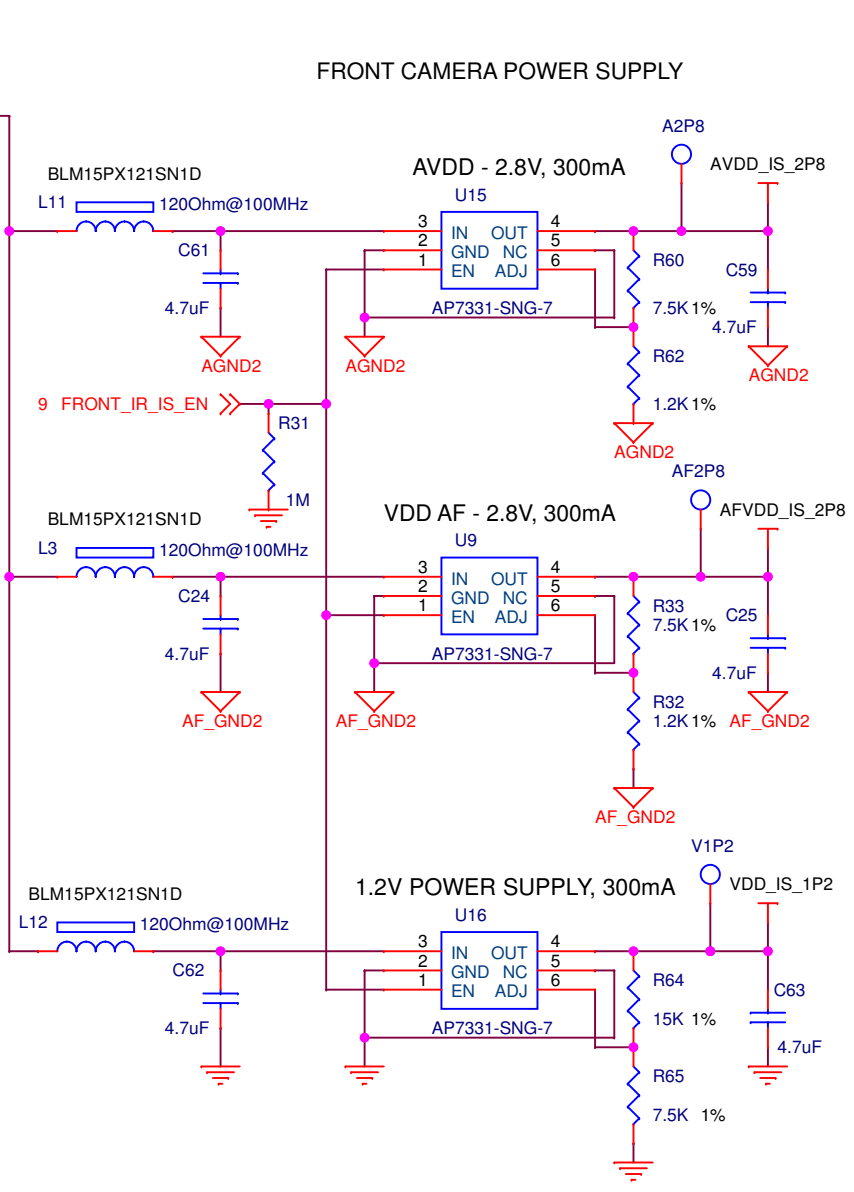
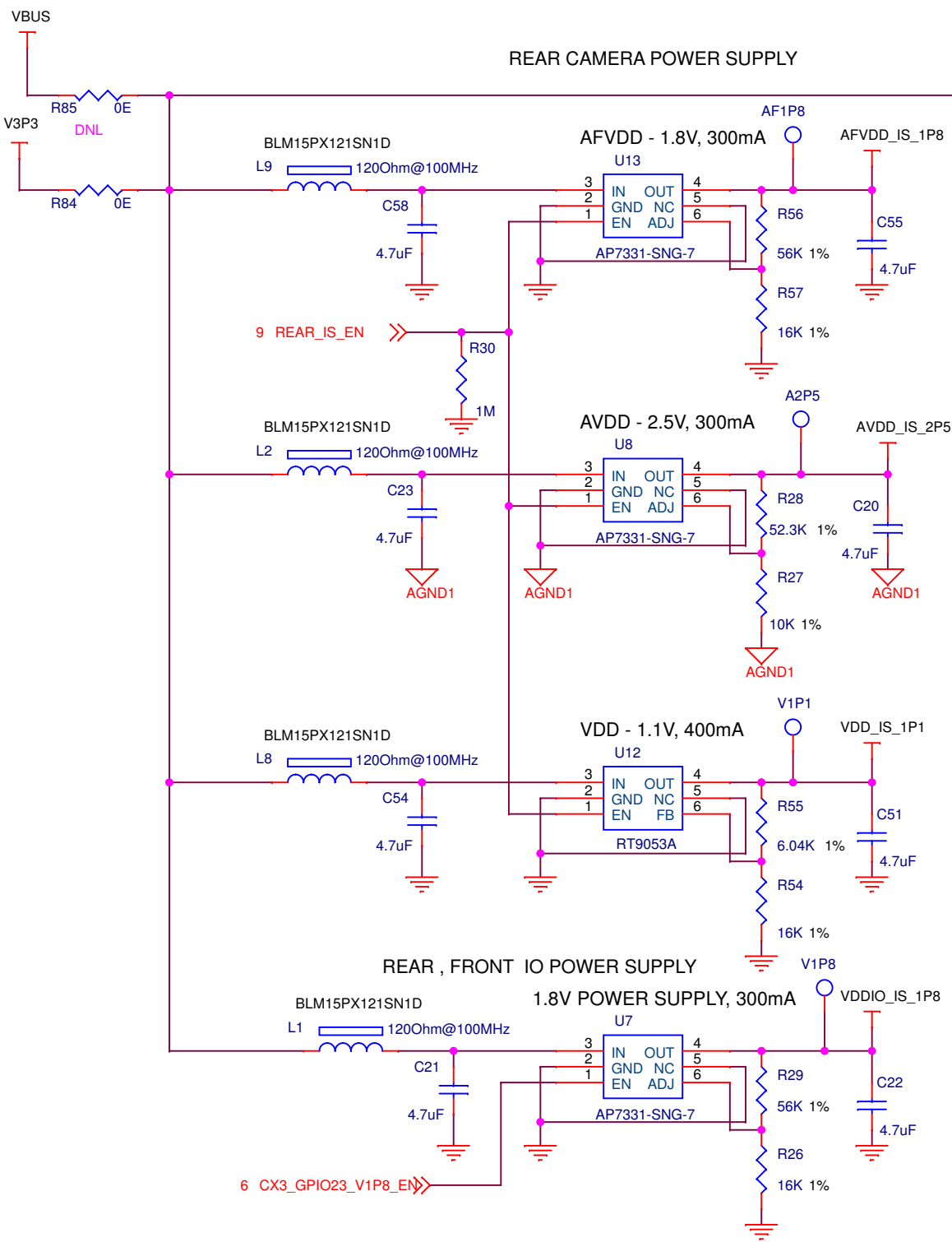

Project Name		
TANIA- Cypress® CX3™ Socionext® ISP Dual AF CAMERA RDK		
Size A4	Page Title	Rev 1.0
IMAGE SENSOR POWER SUPPLY		
Date: Tuesday, October 03, 2017		Sheet 4 of 14

CX3 POWER SUPPLY INTERFACE

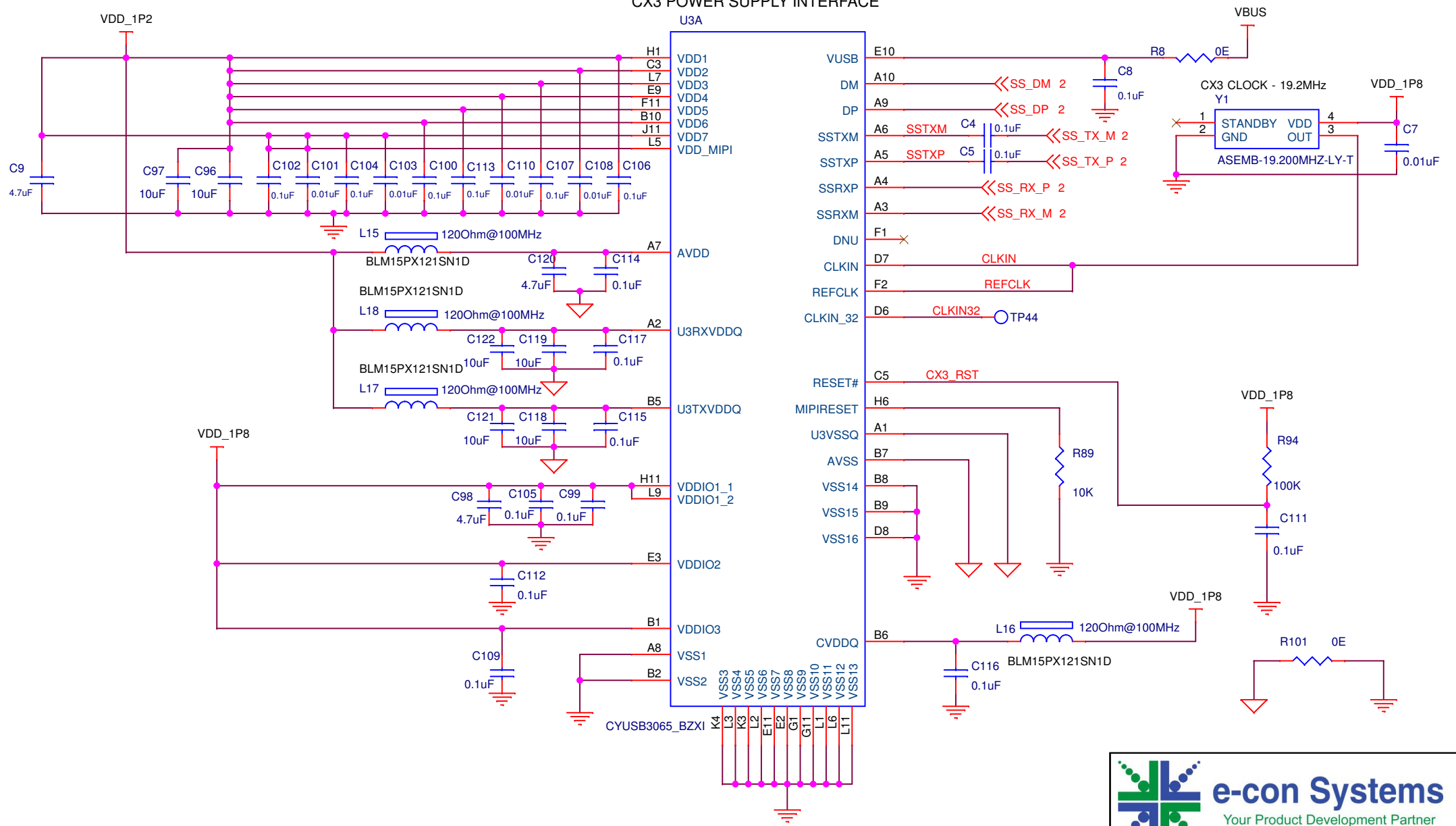

Project Name		
TANIA- Cypress® CX3™ Socionext® ISP Dual AF CAMERA RDK		
Size A4	Page Title	Rev 1.0
CX3 - POWER INTERFACE		
Date: Tuesday, October 03, 2017	Sheet	5 of 14

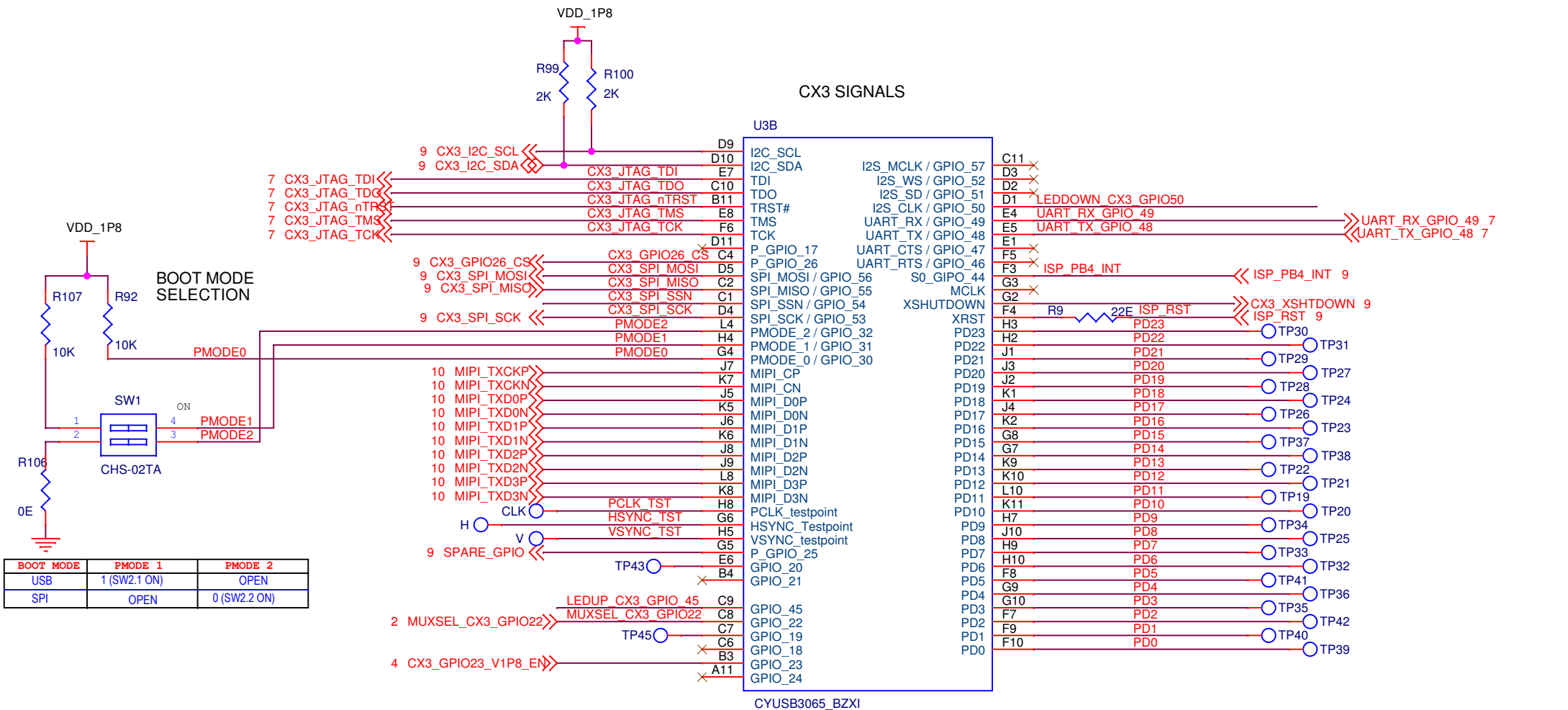

BOOT MODE	PMODE 1	PMODE 2
USB	1 (SW2.1 ON)	OPEN
SPI	OPEN	0 (SW2.2 ON)

e-con Systems
Your Product Development Partner

Project Name
TANIA- Cypress® CX3™ Socionext® ISP Dual AF CAMERA RDK

Size A4	Page Title CX3 - SIGNALS	Rev 1.0
------------	-----------------------------	------------

Date: Tuesday, October 03, 2017 Sheet 6 of 14

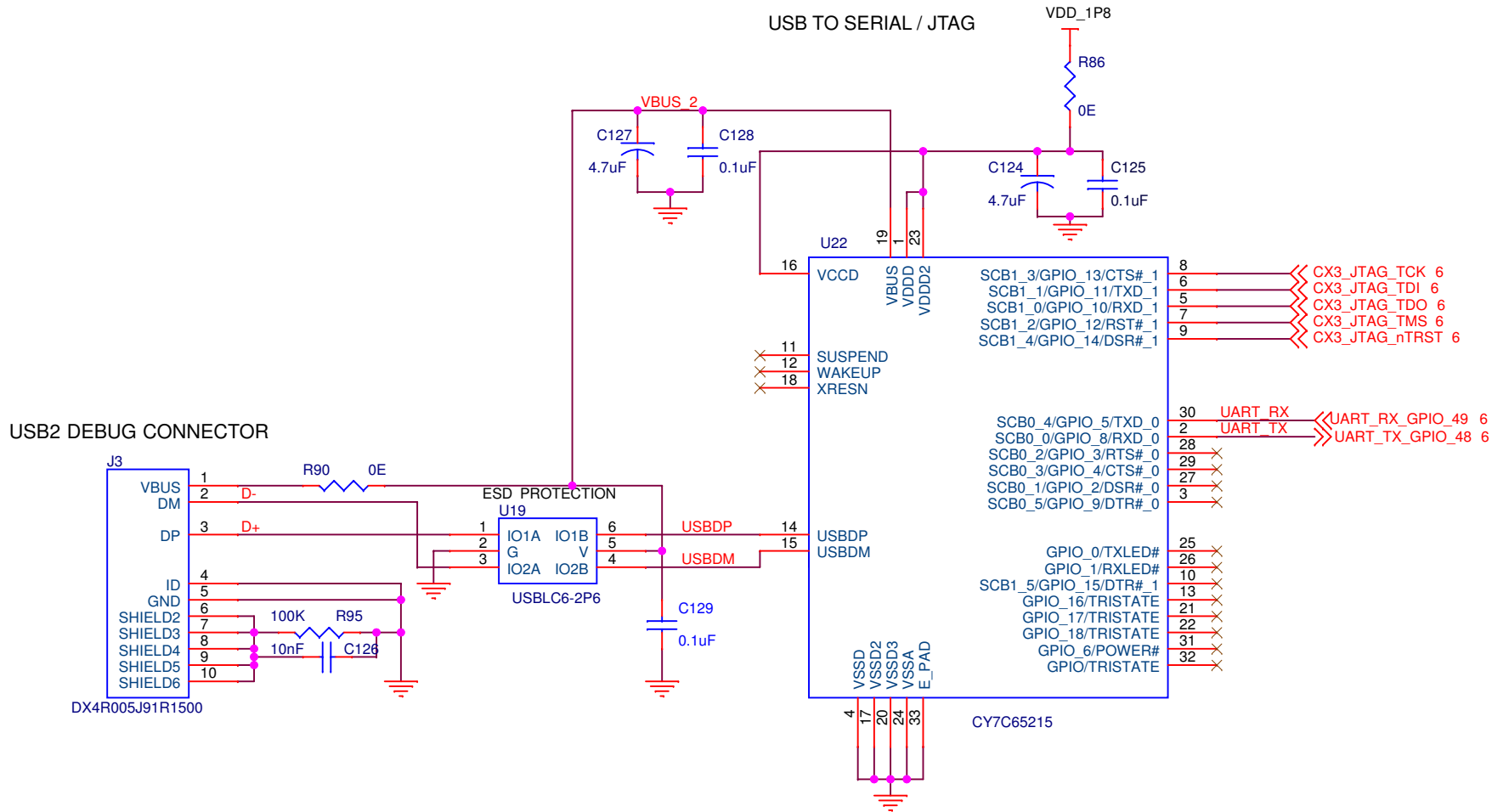

USB2 DEBUG CONNECTOR

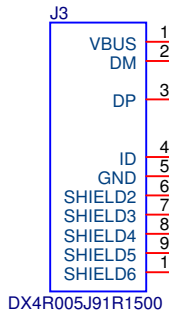

e-con Systems
Your Product Development Partner

Project Name
TANIA- Cypress® CX3™ Socionext® ISP Dual AF CAMERA RDK

Size A4	Page Title DEBUG BOARD - SERIAL, JTAG	Rev 1.0
Date: Tuesday, October 03, 2017		Sheet 7 of 14

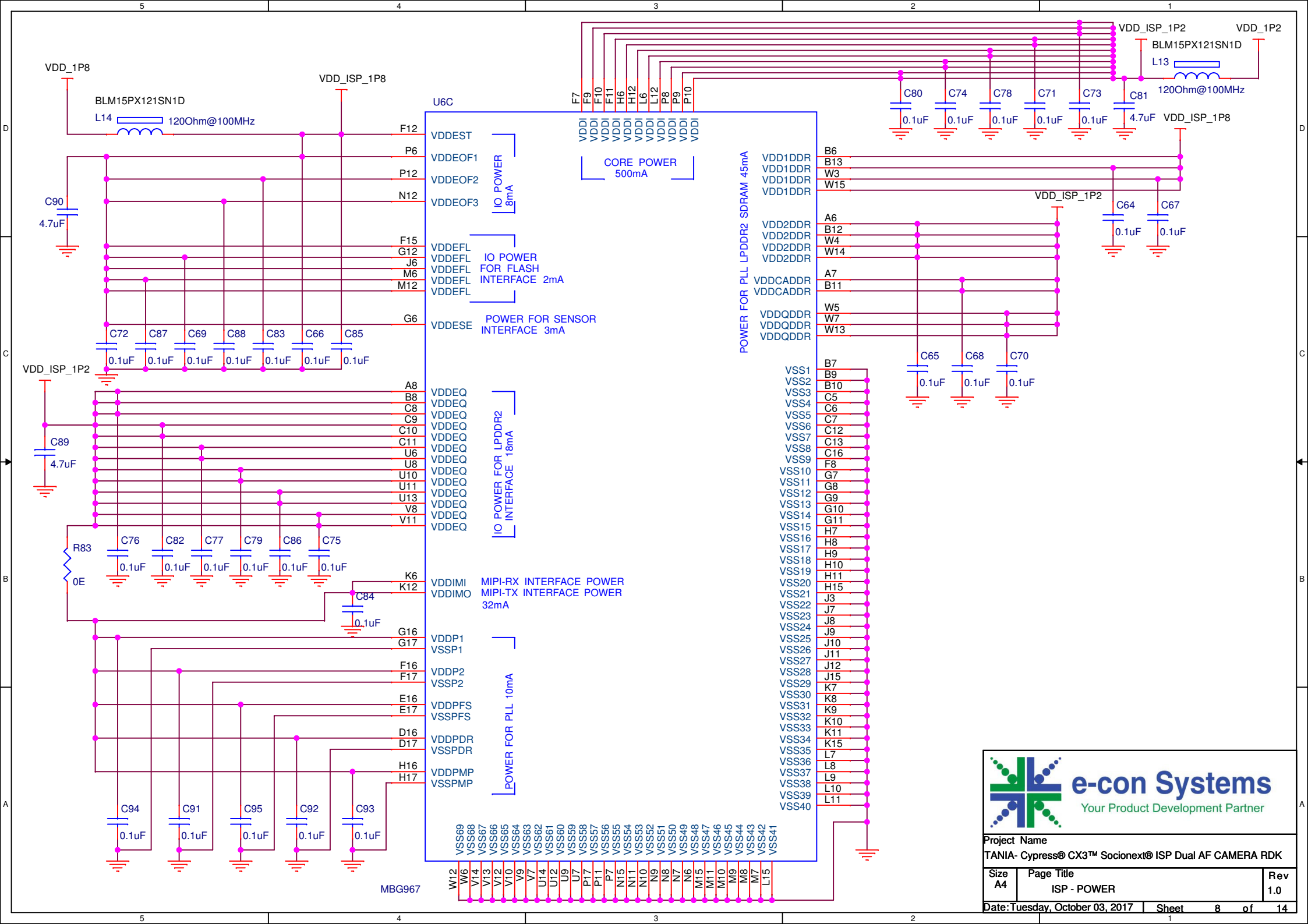

Project Name		
TANIA- Cypress® CX3™ Socionext® ISP Dual AF CAMERA RDK		
Size A4	Page Title	Rev
	ISP - POWER	1.0
Date: Tuesday, October 03, 2017		Sheet 8 of 14

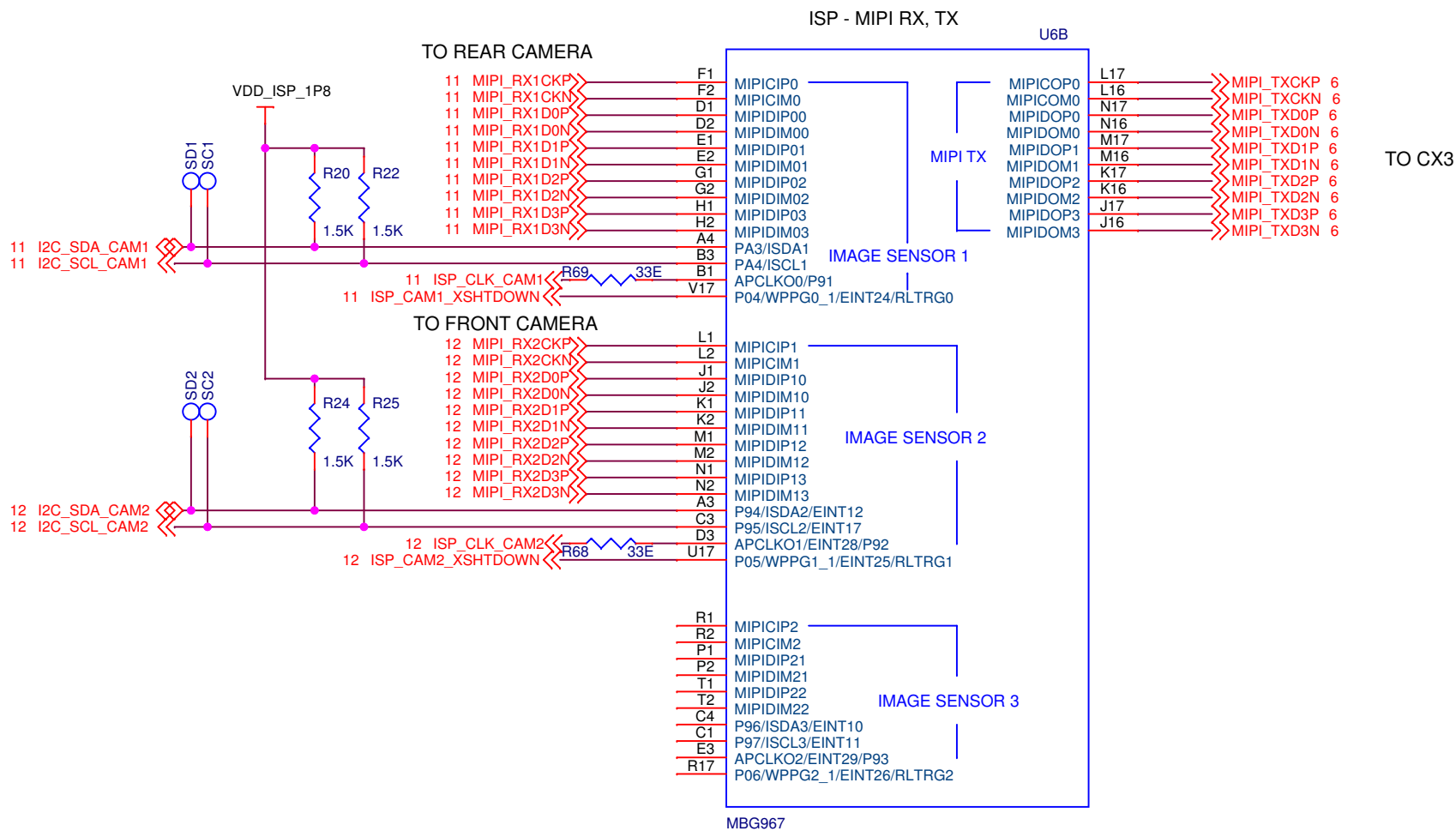

NOTE:
 Following pin no's not present in U7.
 D4-D14
 E4-E14
 F4-5, F13-14
 G4-5, G13-14
 H4-5, H13-14
 J4-5, J13-14
 K4-5, K13-14
 L4-5, L13-14
 M4-5, M13-14
 N4-5, N13-14
 P4-5, P13-14
 R4-14
 T4-14

e-con Systems
 Your Product Development Partner

Project Name		
TANIA- Cypress® CX3™ Socionext® ISP Dual AF CAMERA RDK		
Size	Page Title	Rev
A4	ISP - MIPI RX, TX	1.0
Date: Tuesday, October 03, 2017		Sheet 10 of 14

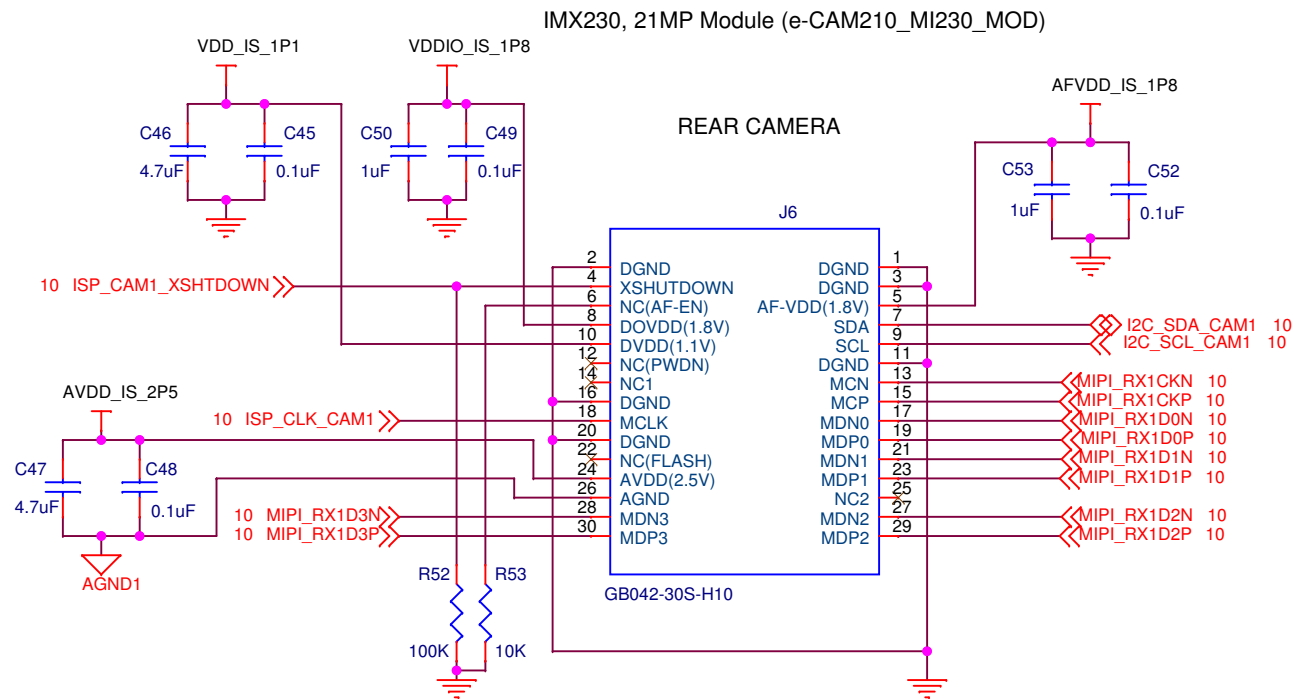



e-con Systems

Your Product Development Partner

Project Name		
TANIA- Cypress® CX3™ Socionext® ISP Dual AF CAMERA RDK		
Size A4	Page Title IMAGE SENSOR - PRIMARY	Rev 1.0
Date: Tuesday, October 03, 2017		Sheet 11 of 14

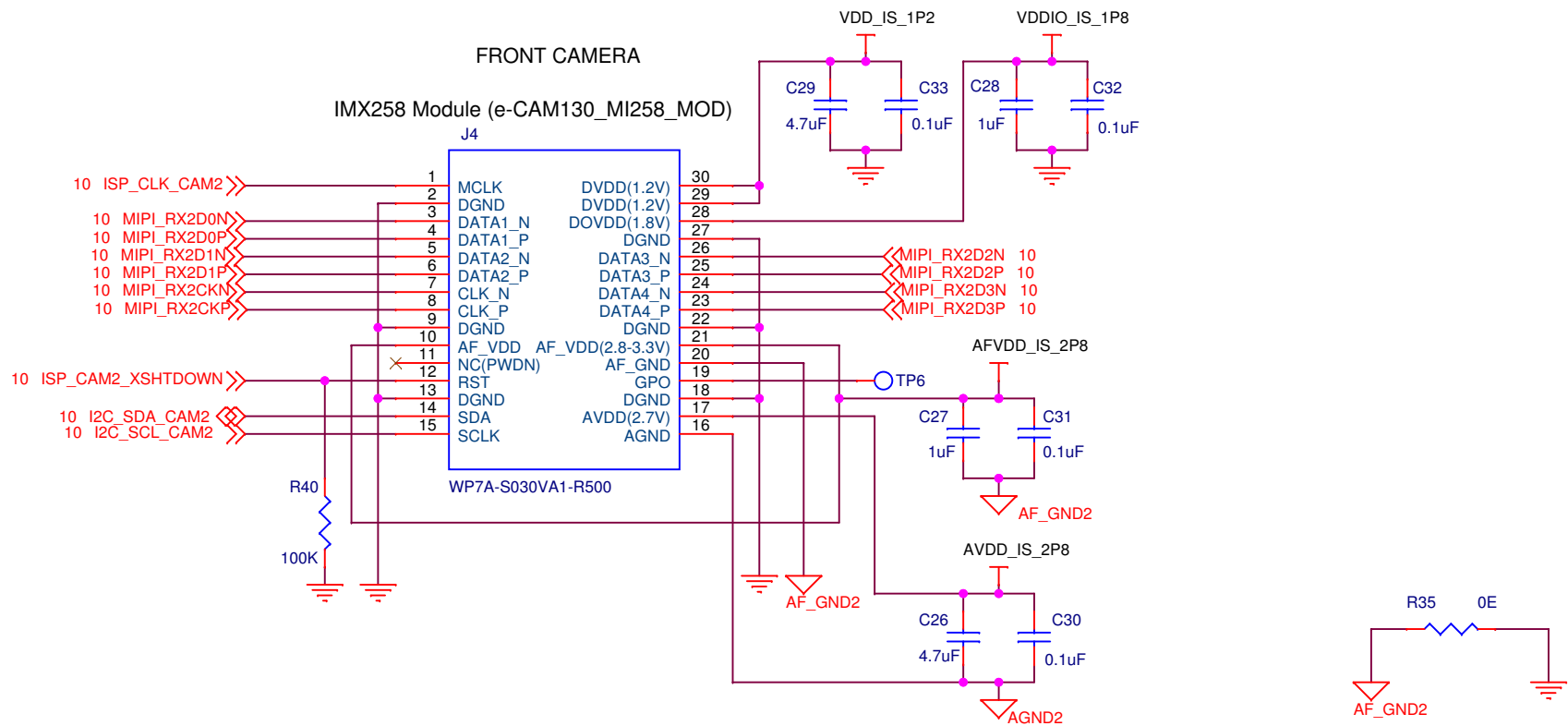

Project Name
TANIA- Cypress® CX3™ Socionext® ISP Dual AF CAMERA RDK

Size A4	Page Title IMAGE SENSOR - SECONDARY	Rev 1.0
------------	--	------------

Date: Tuesday, October 03, 2017 | Sheet 12 of 14

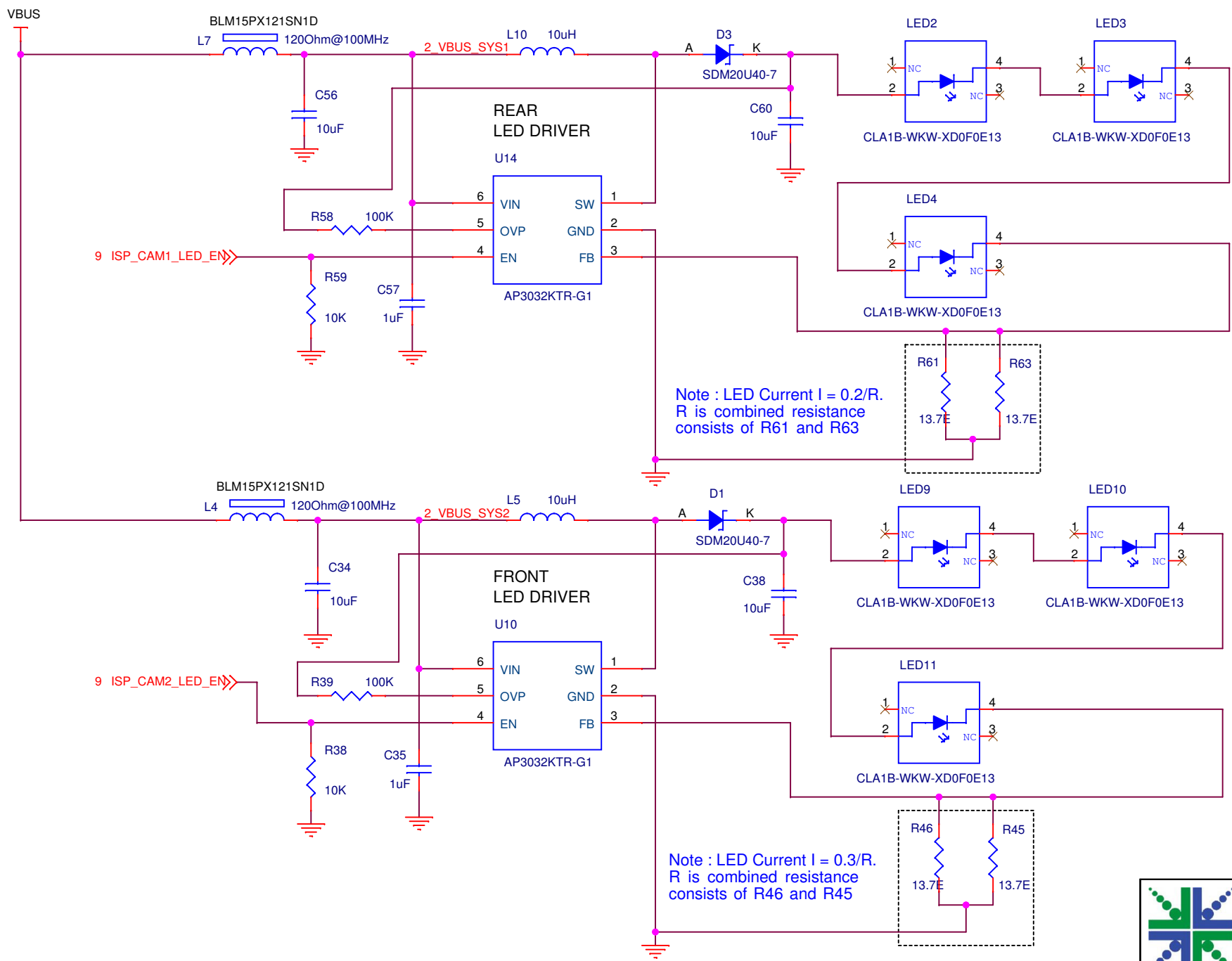

Note : LED Current $I = 0.2/R$.
 R is combined resistance
 consists of R61 and R63

Note : LED Current $I = 0.3/R$.
 R is combined resistance
 consists of R46 and R45



Project Name		
TANIA- Cypress® CX3™ Socionext® ISP Dual AF CAMERA RDK		
Size A4	Page Title LED FLASH DRIVER	Rev 1.0
Date: Tuesday, October 03, 2017		
Sheet 13 of 14		

Revision	Description of the change
1.0	Initial Release

