

FX3 DVK DEVICE BOARD

REV - 3.0

PAGE 01 : INDEX PAGE
PAGE 02 : P-PORT CONNECTIONS 1
PAGE 03 : P/S0/S1 PORT TO SAMTEC
PAGE 04 : MICTOR CONNECTIONS
PAGE 05 : S0/S1 PORT CONNECTIONS
PAGE 06 : S1 TO UART/I2C EEPROM
PAGE 07 : CLOCK SIGNALS
PAGE 08 : JTAG CONNECTIONS
PAGE 09 : USB CONNECTIONS
PAGE 10 : FX3 POWER
PAGE 11 : 5V INPUT / 3.3V - 2.5V REG
PAGE 12 : 1.2V / 1.8V REG
PAGE 13 : POWER CONNECTORS
PAGE 14 : POWER LED'S

PCB NUMBER : 600-60015-01 REV03

FAB DRAWING NUMBER : 610-60012-01 REV03

ASSEMBLY DRAWING NUMBER : 620-60013-01 REV03

SCHEMATIC NUMBER : 630-60013-01 REV03

| | | |
|----------------------|------------------------------|---------------|
| Title | | |
| FX3 DVK DEVICE BOARD | | |
| Size | Document Number | Rev |
| B | 630-60013-01 REV02 | 2.0 |
| Date: | Thursday, September 08, 2011 | Sheet 1 of 14 |

P-PORT CONNECTIONS

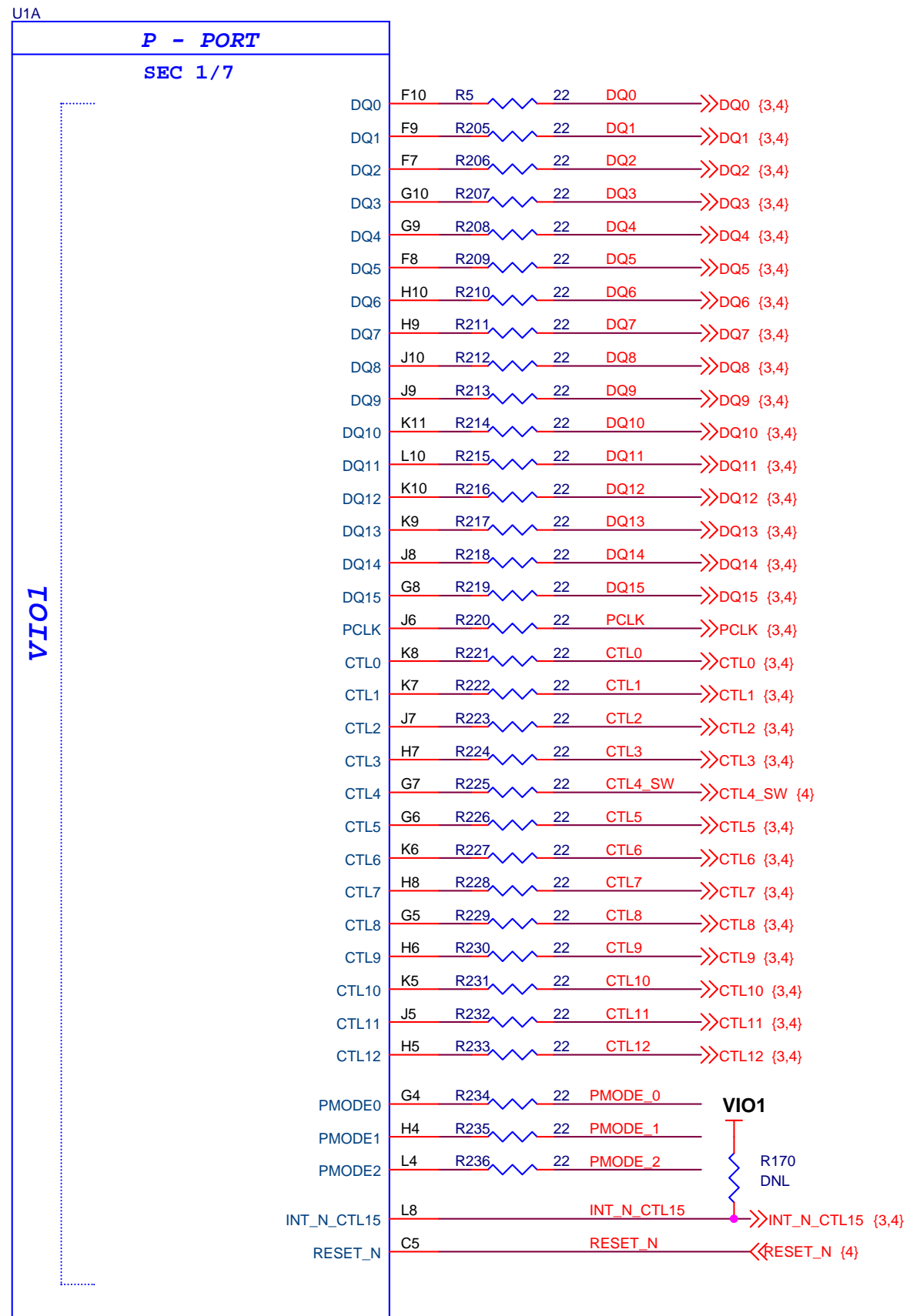

FX3_121_BUMP

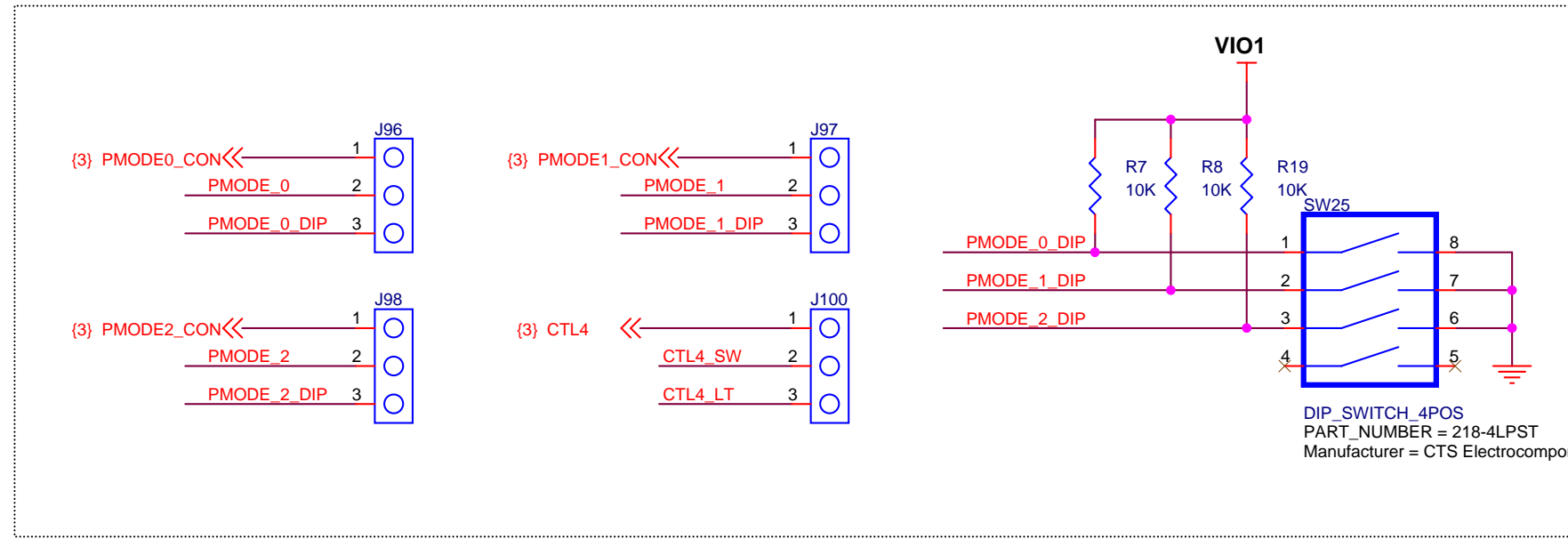

RESET_CONNECTION

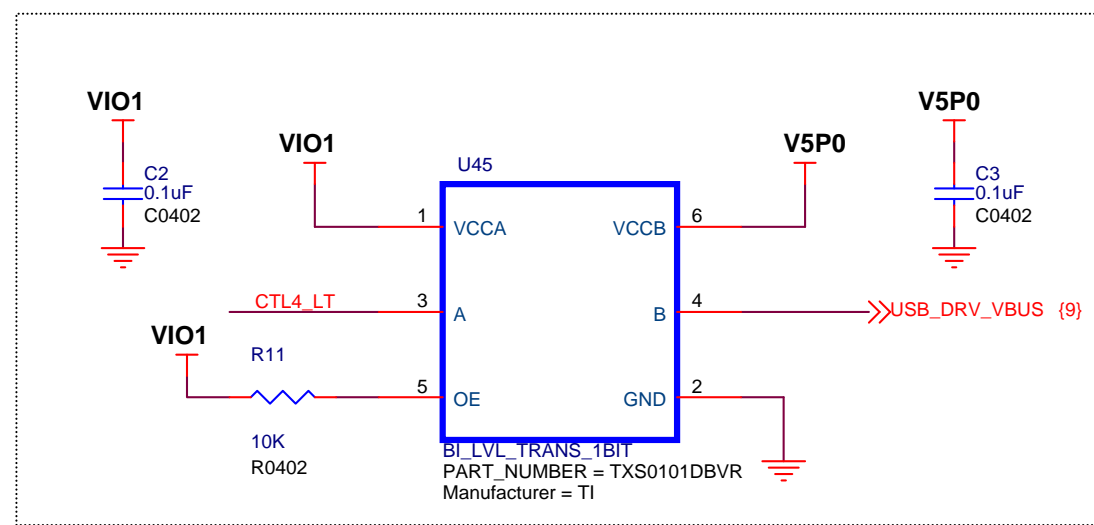
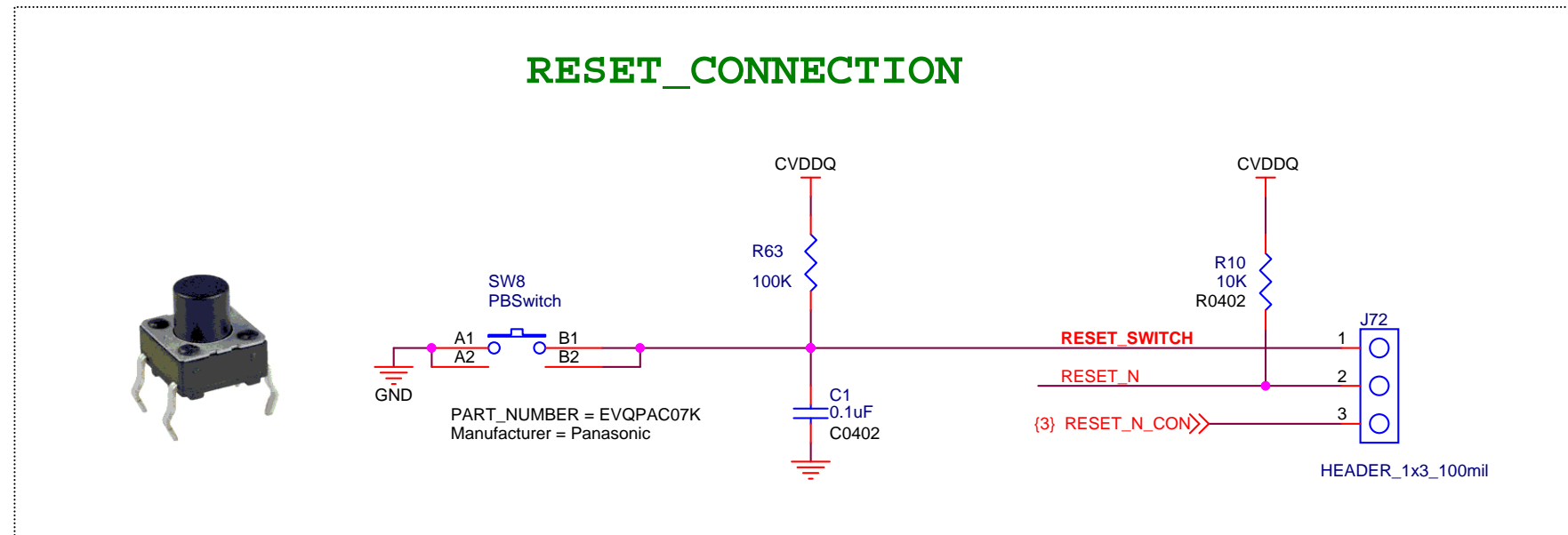

| | | |
|----------------------|------------------------------|---------------|
| Title | | |
| FX3 DVK DEVICE BOARD | | |
| Size B | Document Number | Rev |
| | 630-60013-01 REV02 | 2.0 |
| Date: | Thursday, September 08, 2011 | Sheet 2 of 14 |

P PORT TO SAMTEC

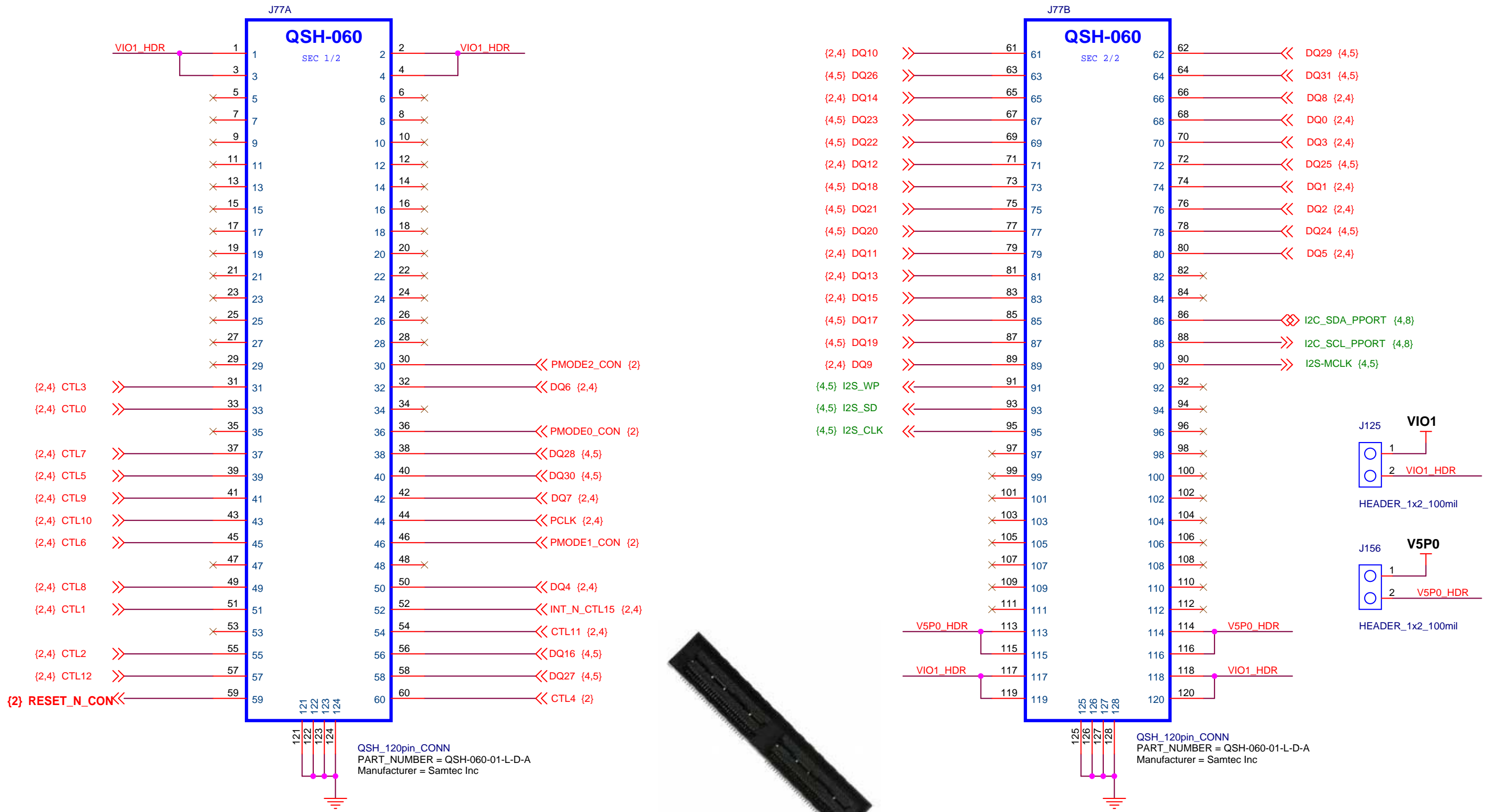

| | | |
|----------------------|------------------------------|---------------|
| Title | | |
| FX3 DVK DEVICE BOARD | | |
| Size | Document Number | Rev |
| B | 630-60013-01 REV02 | 2.0 |
| Date: | Thursday, September 08, 2011 | Sheet 3 of 14 |

MICTOR CONNECTIONS

P-PORT SIGNALS

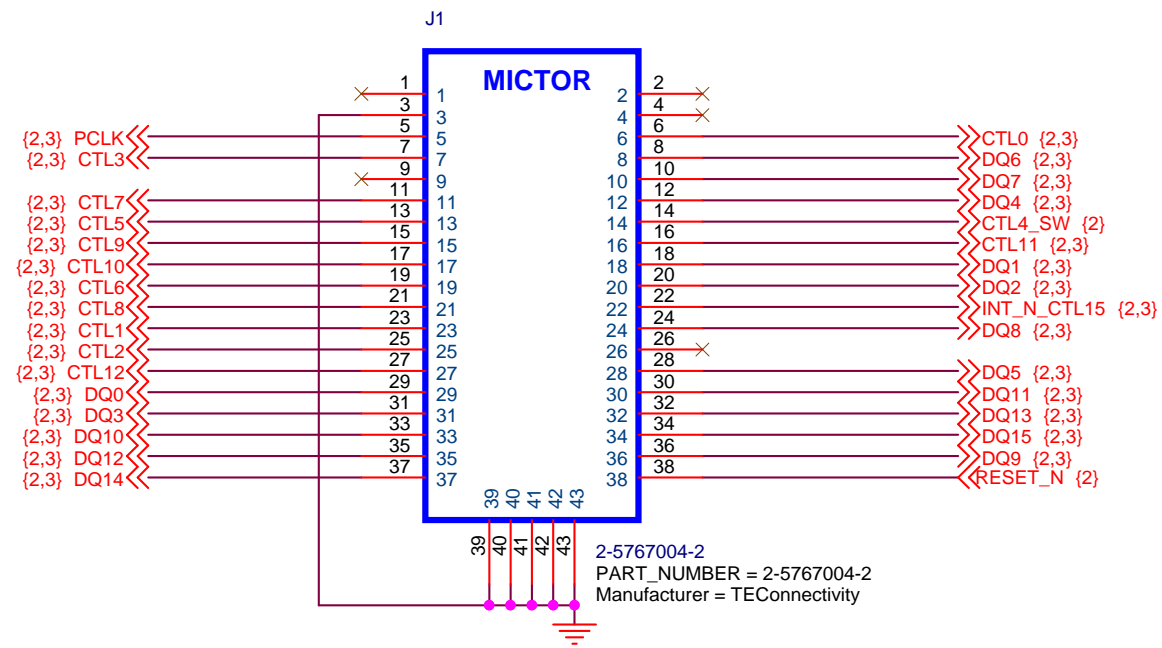

S0/S1-PORT SIGNALS

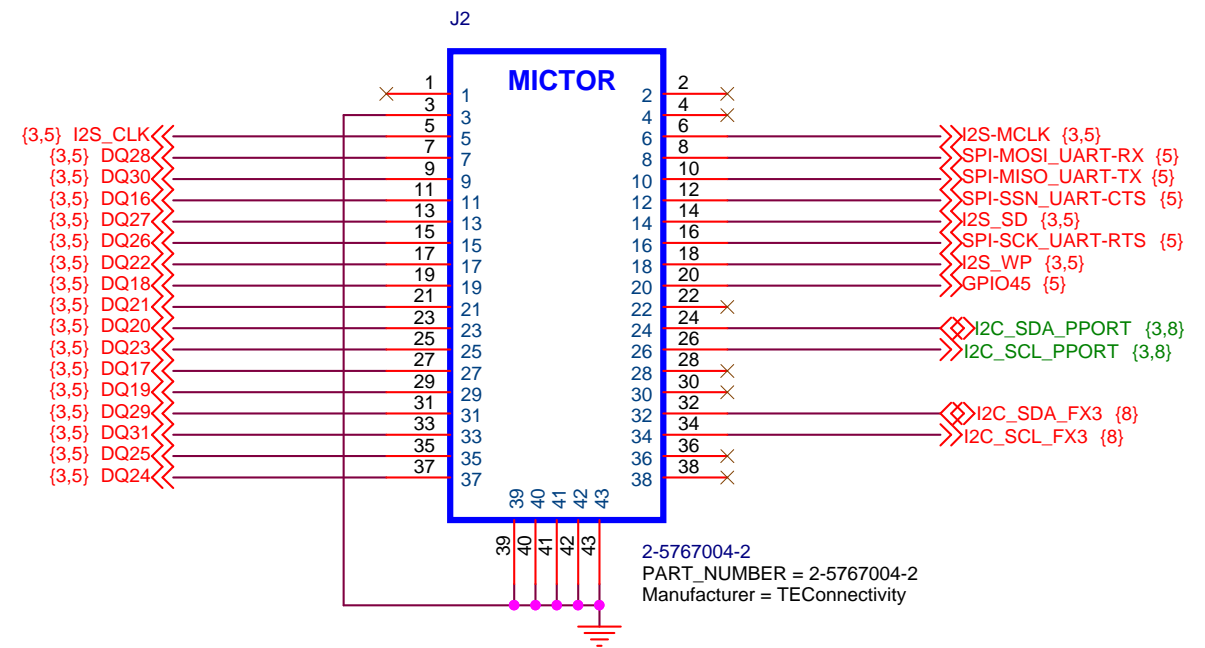

| | | |
|----------------------|------------------------------|---------------|
| Title | | |
| FX3 DVK DEVICE BOARD | | |
| Size | Document Number | Rev |
| B | 630-60013-01 REV03 | 3.0 |
| Date: | Thursday, September 08, 2011 | Sheet 4 of 14 |

S0-PORT CONNECTIONS

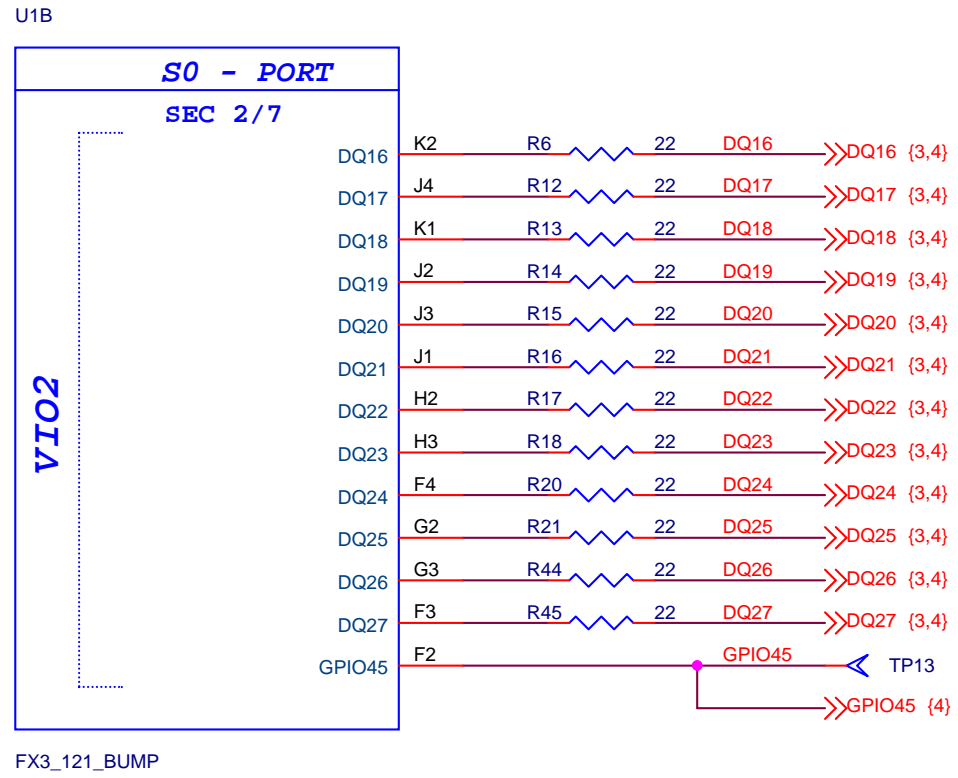

S1-PORT CONNECTIONS

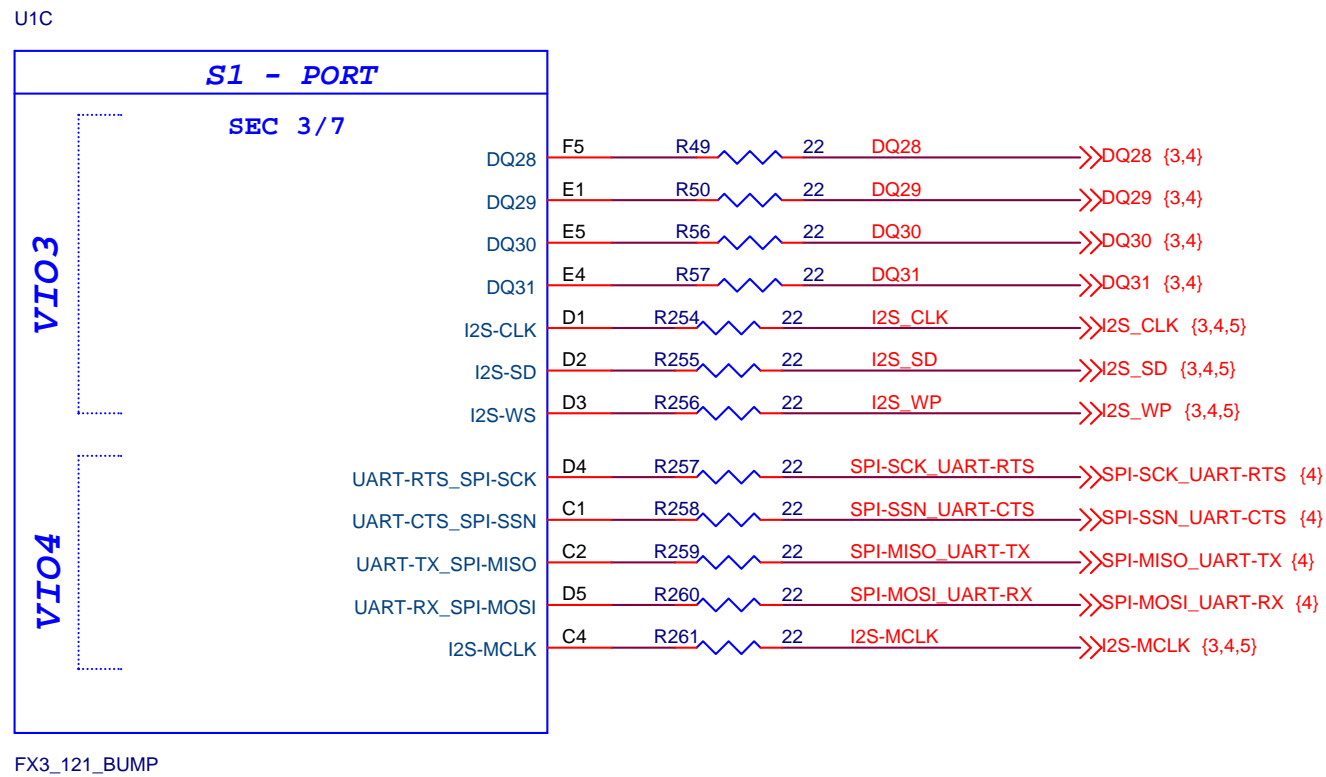

I2S HEADER

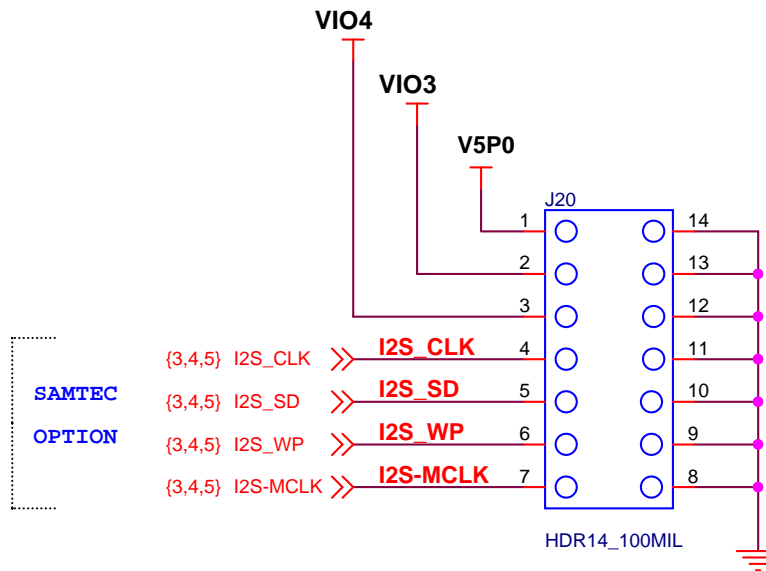

SPI HEADER

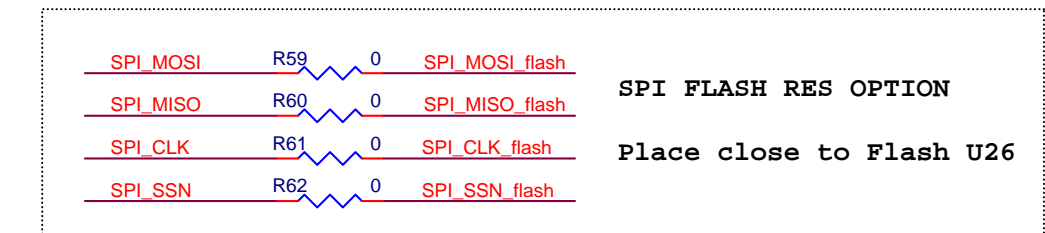
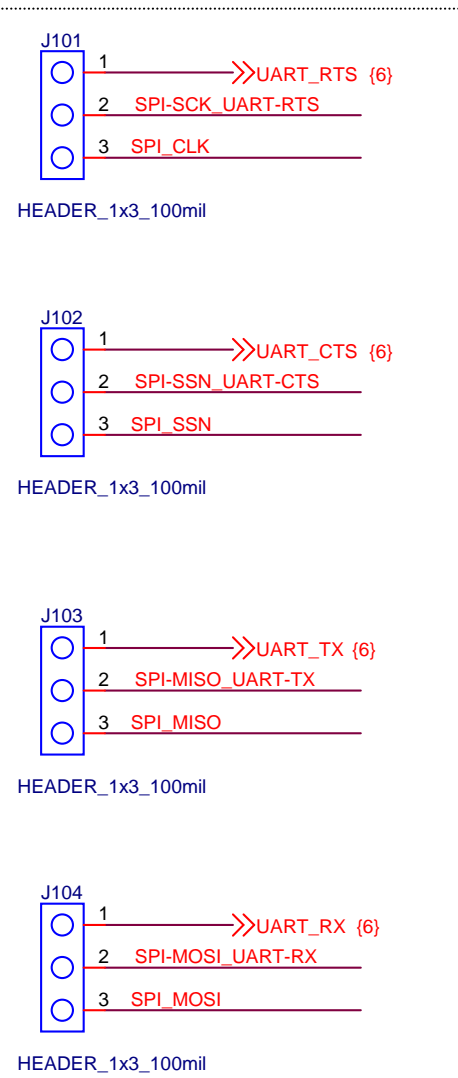
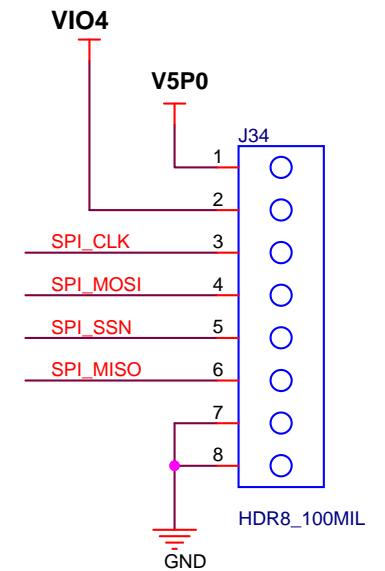

SPI Flash

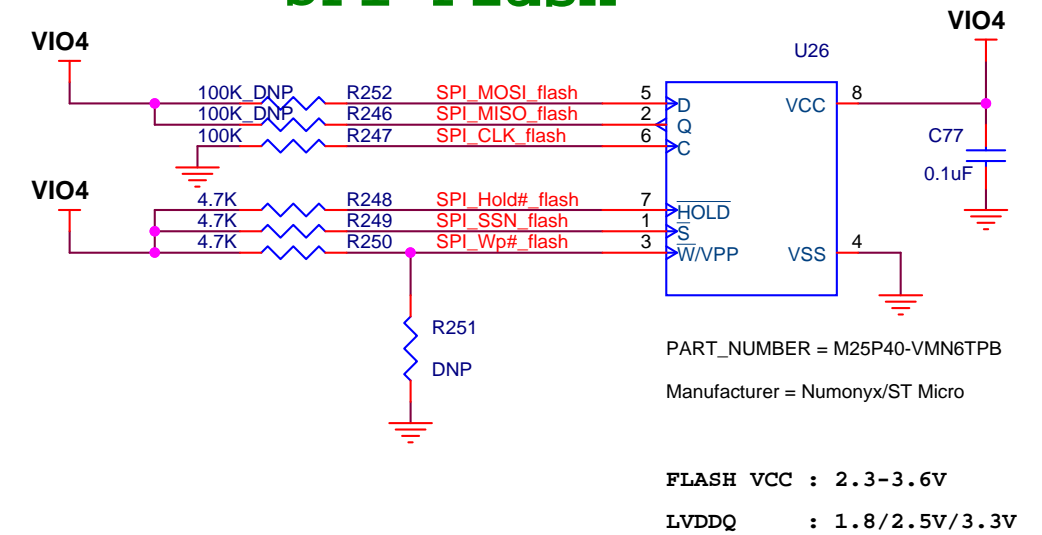

| | | |
|----------------------|---------------------------------------|---------------|
| Title | | |
| FX3 DVK DEVICE BOARD | | |
| Size B | Document Number 630-60013-01 REV02 | Rev 2.0 |
| Date: | Thursday, June 21, 2012 | Sheet 5 of 14 |

S1 UART CONNECTIONS

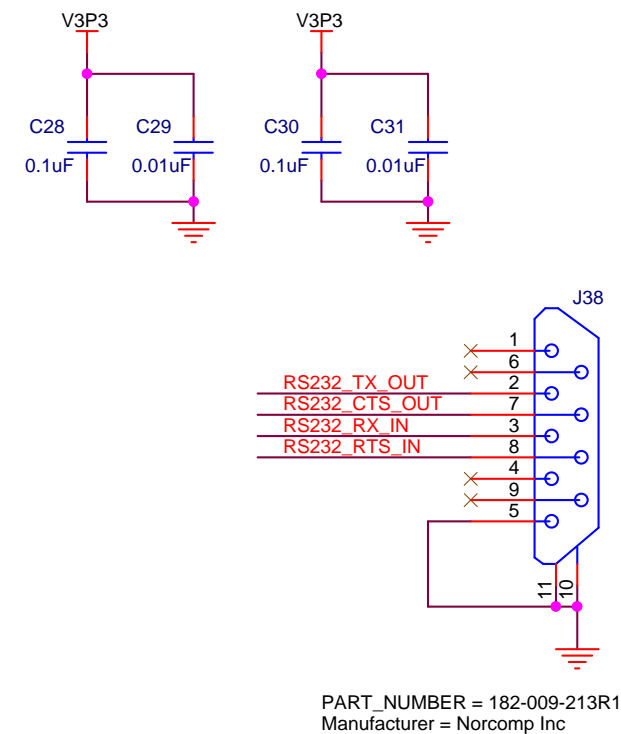
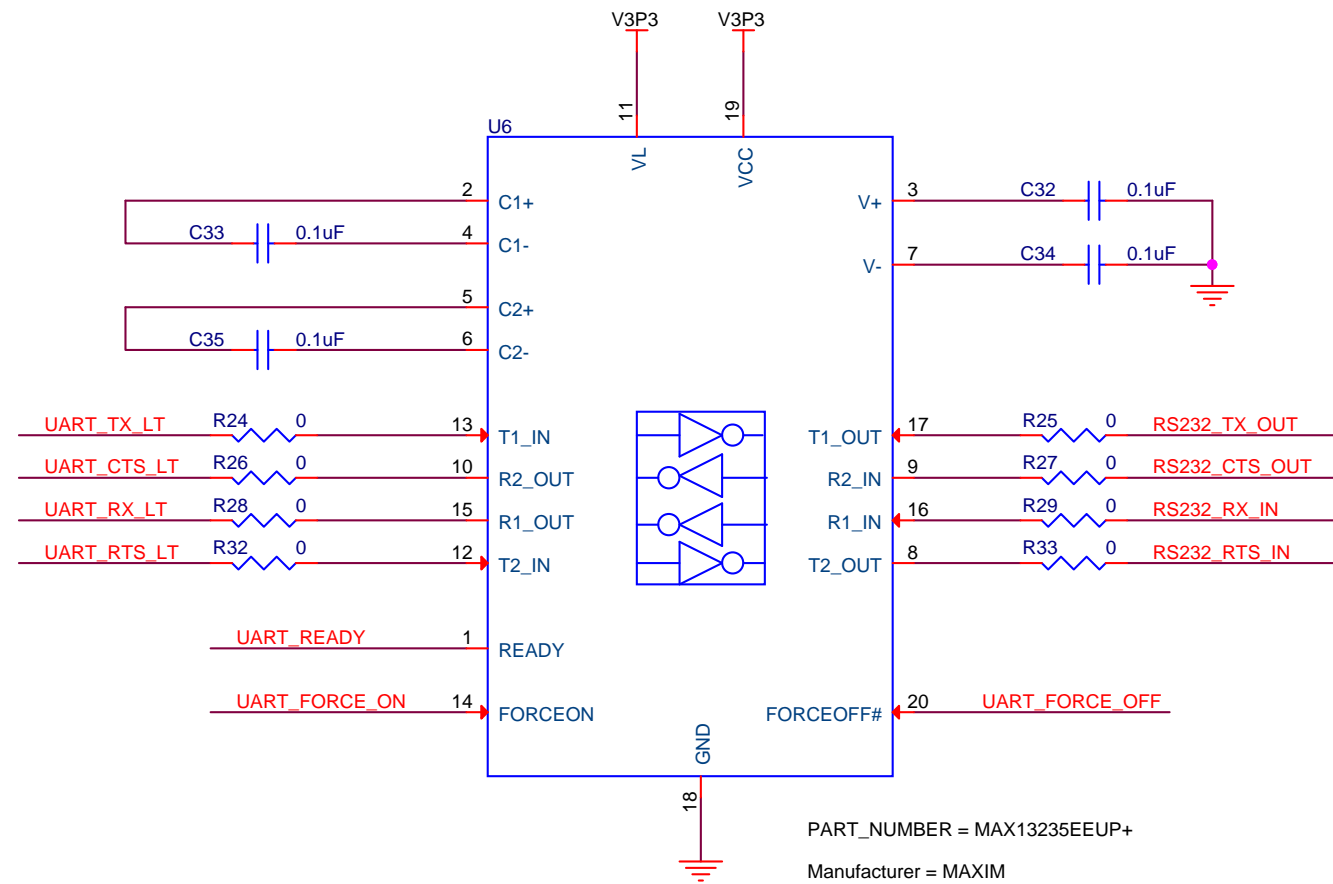
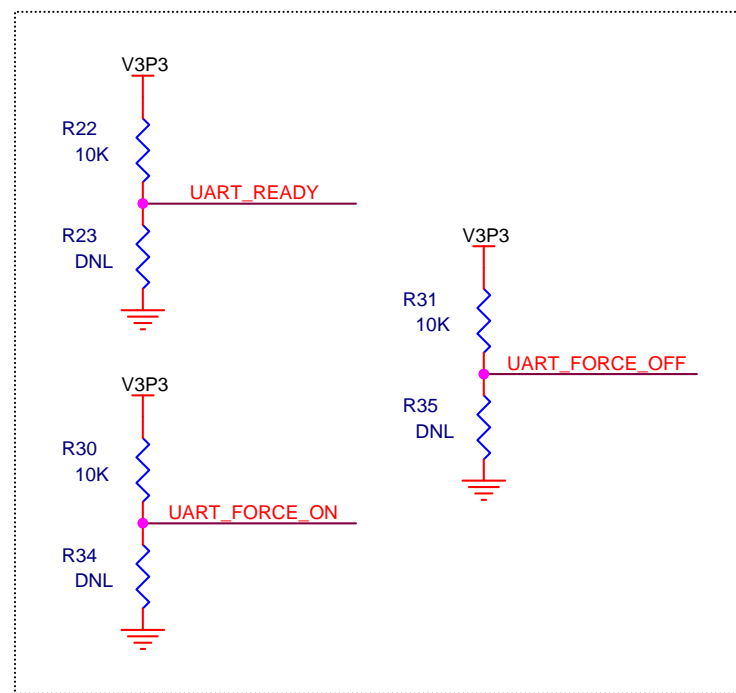

LEVEL TRANSLATOR

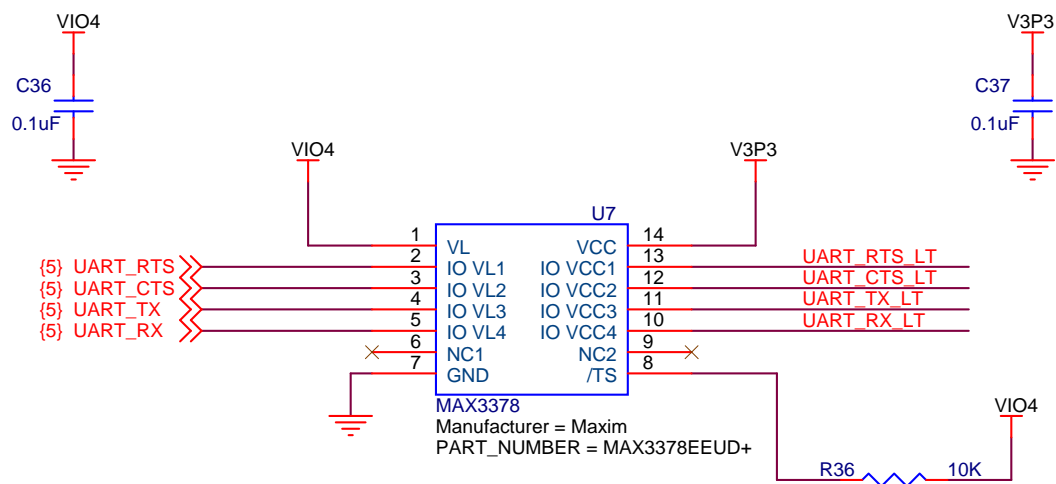

I2C EEPROM

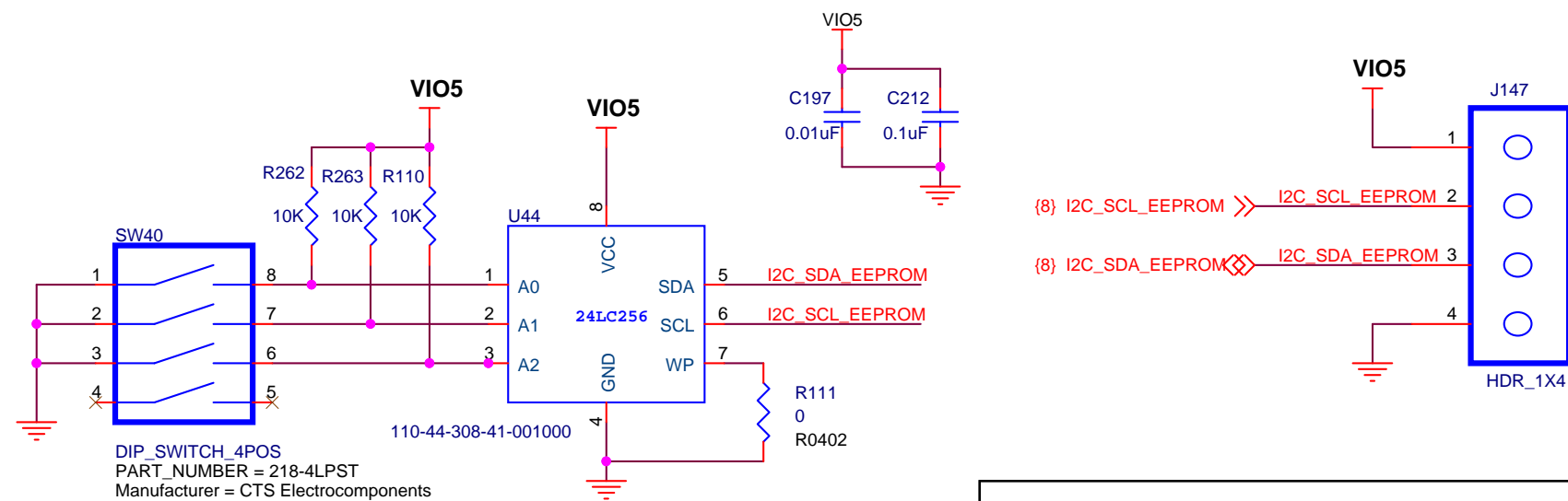

| | | |
|----------------------|------------------------------|---------------|
| Title | | |
| FX3 DVK DEVICE BOARD | | |
| Size | Document Number | Rev |
| B | 630-60013-01 REV03 | 3.0 |
| Date: | Thursday, September 08, 2011 | Sheet 6 of 14 |

CLOCK SIGNALS

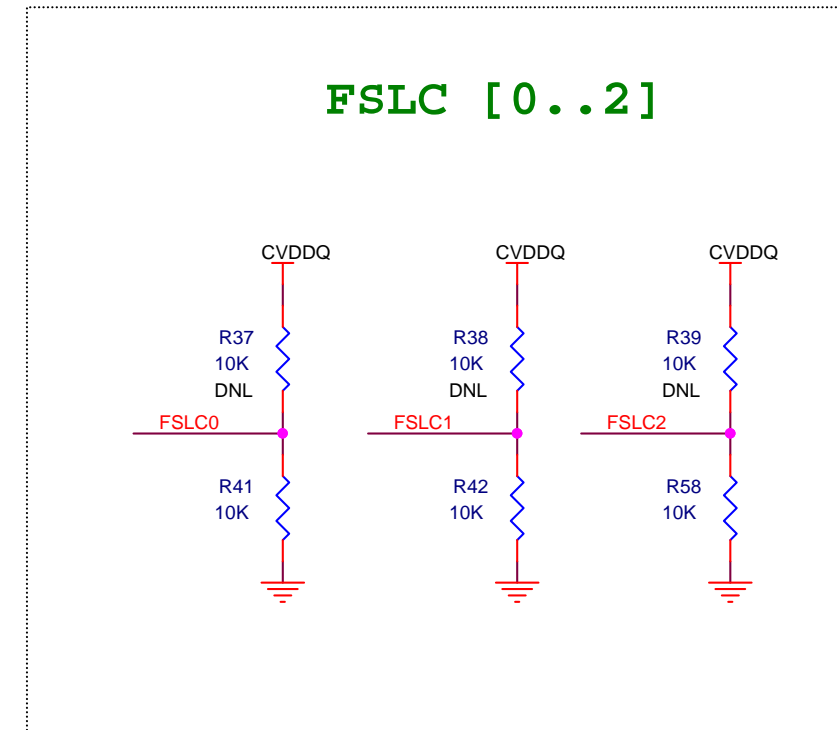
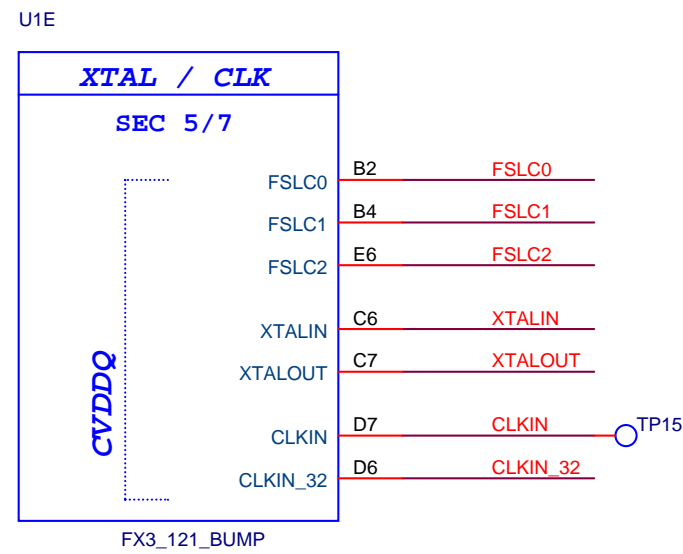

CRYSTAL

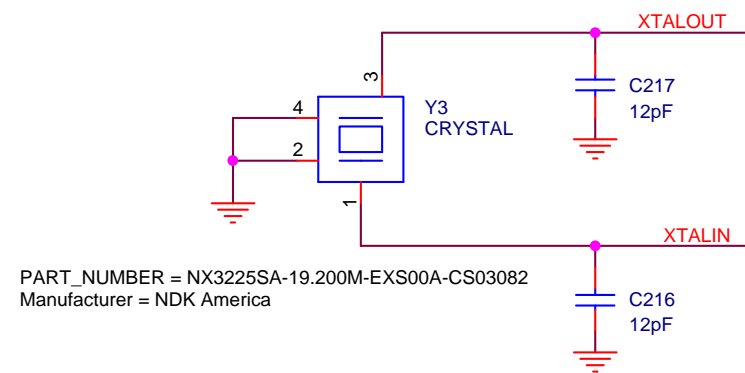

CLOCK IN_32

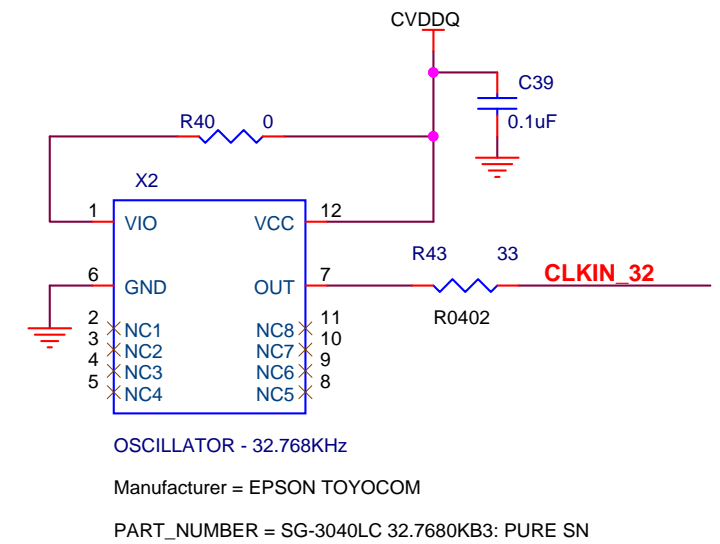

| | | |
|----------------------|------------------------------|---------------|
| Title | | |
| FX3 DVK DEVICE BOARD | | |
| Size | Document Number | Rev |
| B | 630-60013-01 REV03 | 3.0 |
| Date: | Thursday, September 08, 2011 | Sheet 7 of 14 |

JTAG CONNECTIONS

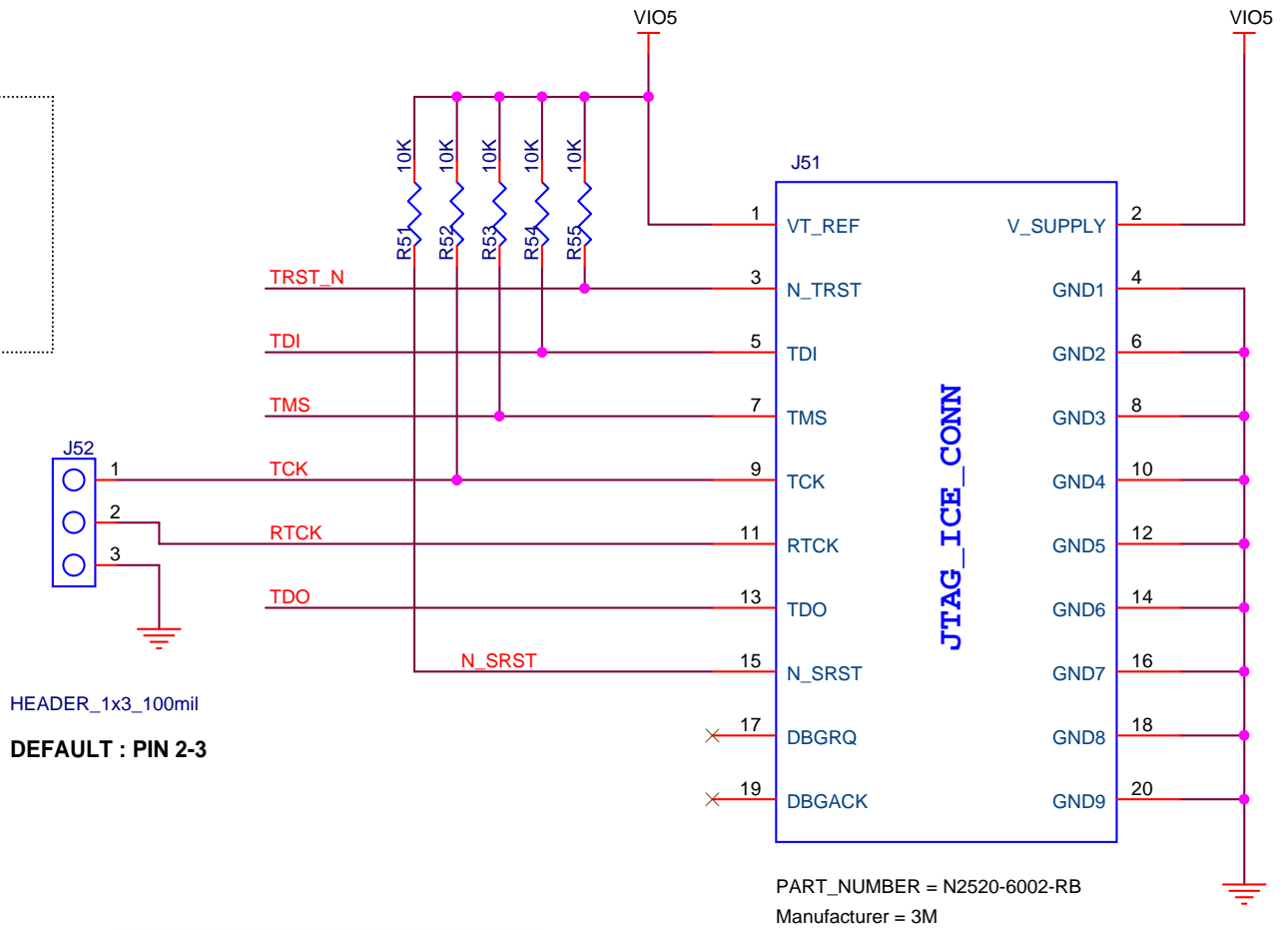
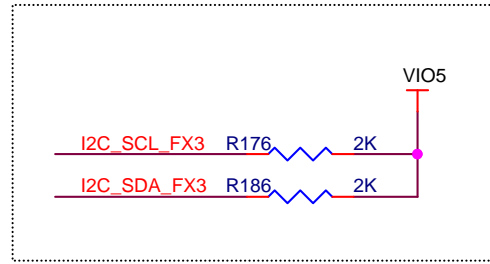
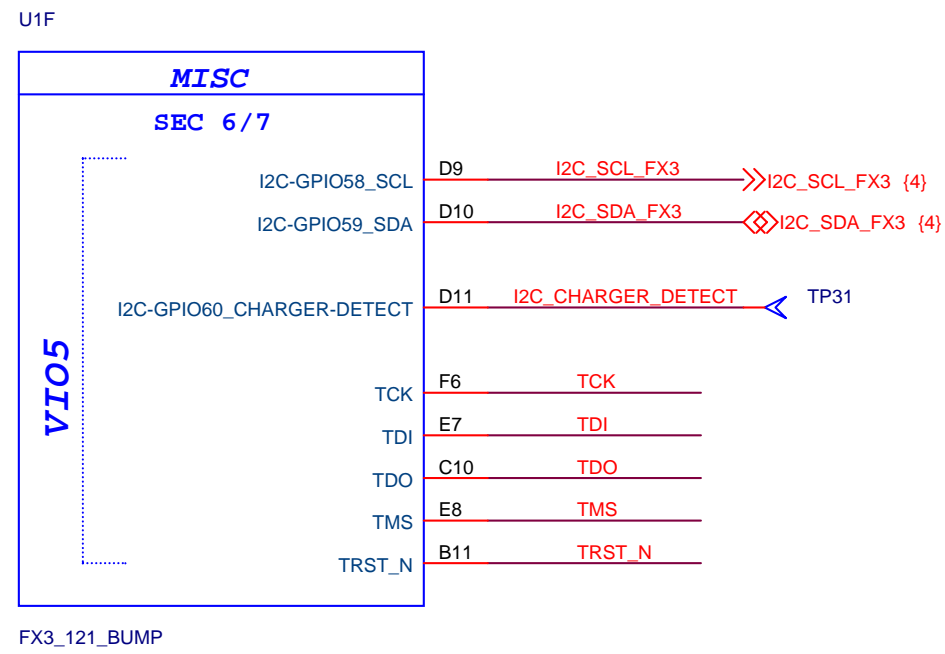

HEADER_1x3_100mil
DEFAULT : PIN 2-3

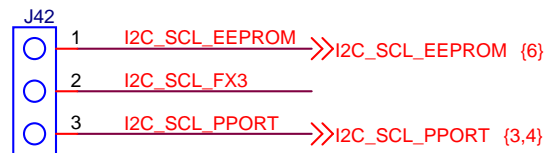

HEADER_1x3_100mil

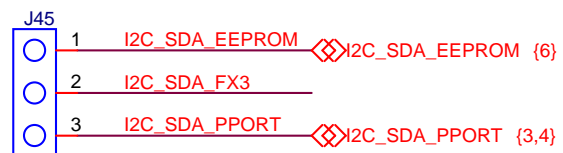

HEADER_1x3_100mil

| | | |
|----------------------|------------------------------|---------------|
| Title | | |
| FX3 DVK DEVICE BOARD | | |
| Size | Document Number | Rev |
| B | 630-60013-01 REV03 | 3.0 |
| Date: | Thursday, September 08, 2011 | Sheet 8 of 14 |

USB CONNECTIONS

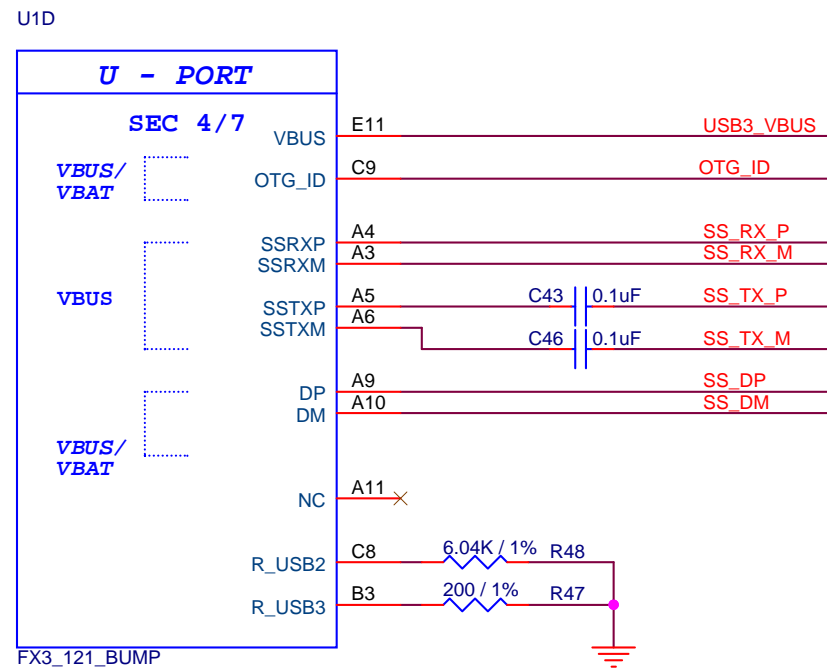

USB Positive Overvoltage Protection Controller

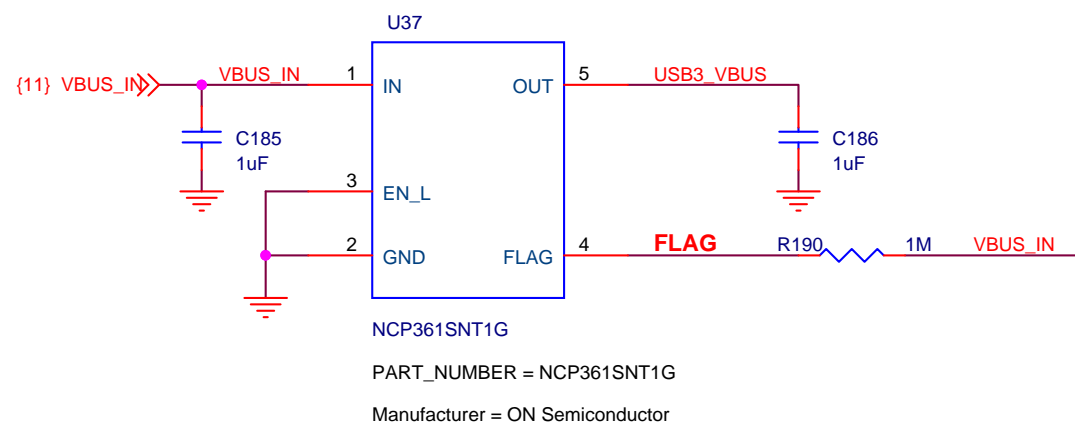

USB SWITCH

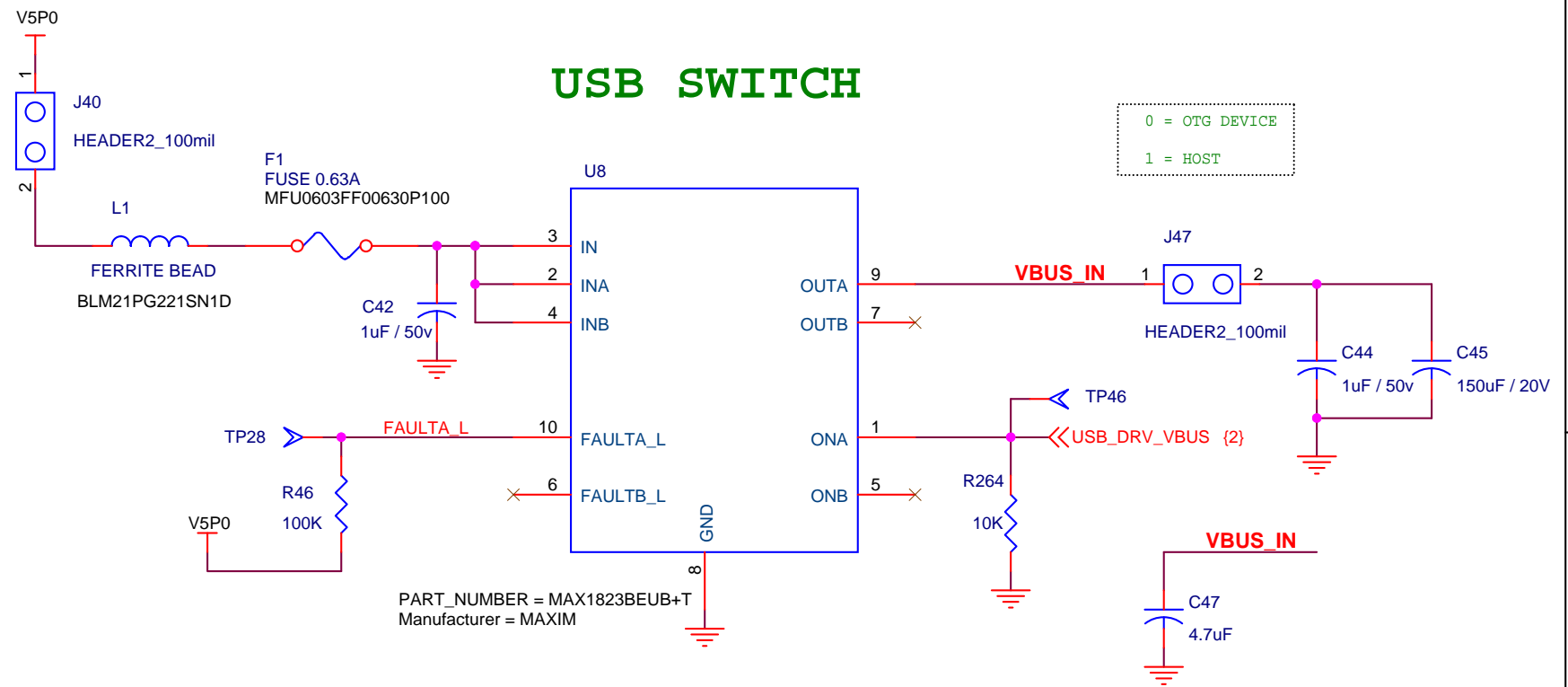

USB3.0 MICRO -TYPE B

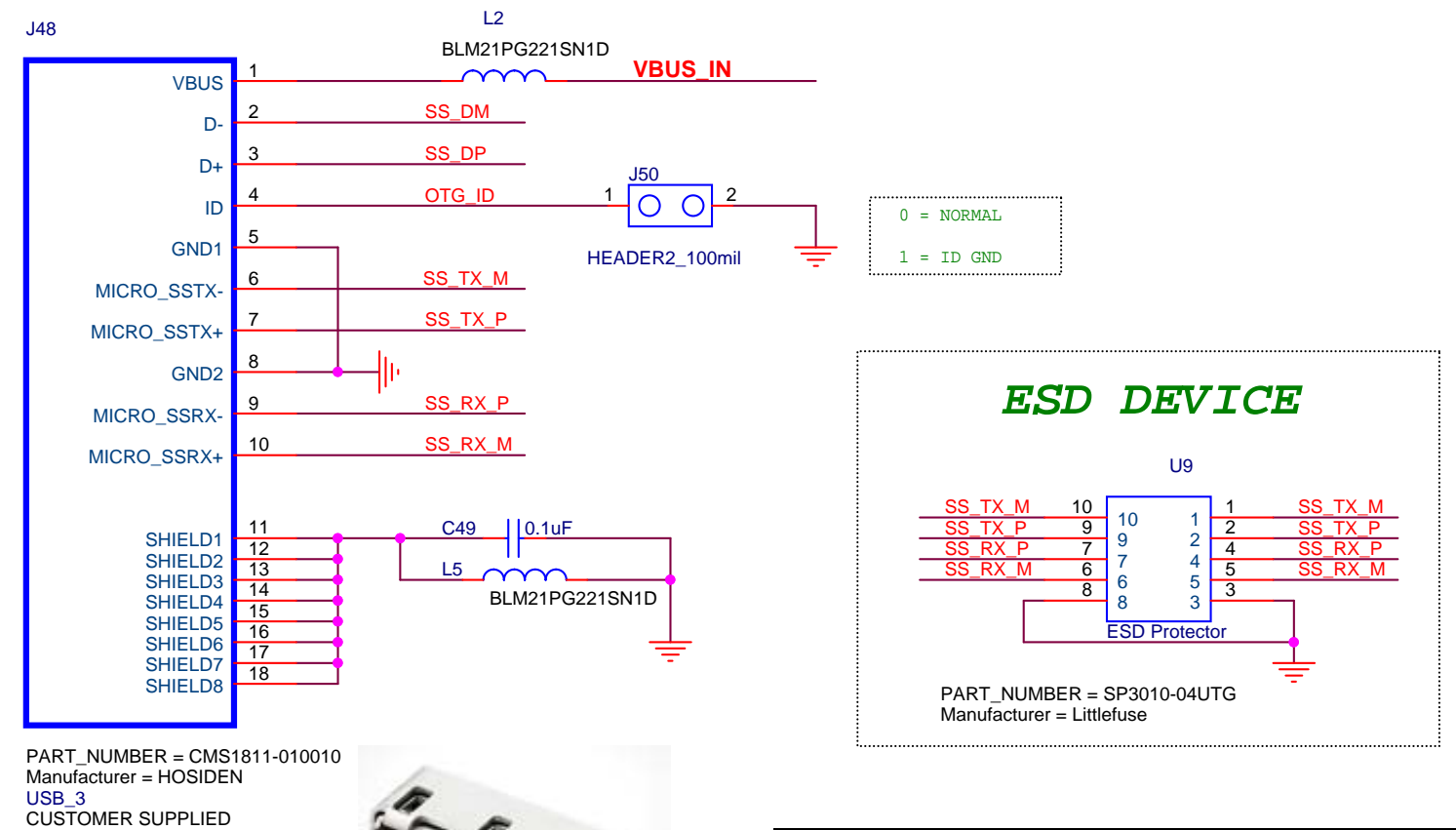

| | | |
|----------------------|------------------------------|---------------|
| Title | | |
| FX3 DVK DEVICE BOARD | | |
| Size B | Document Number | Rev |
| | 630-60013-01 REV03 | 3.0 |
| Date: | Thursday, September 08, 2011 | Sheet 9 of 14 |

FX3 POWER & DECOUPLING

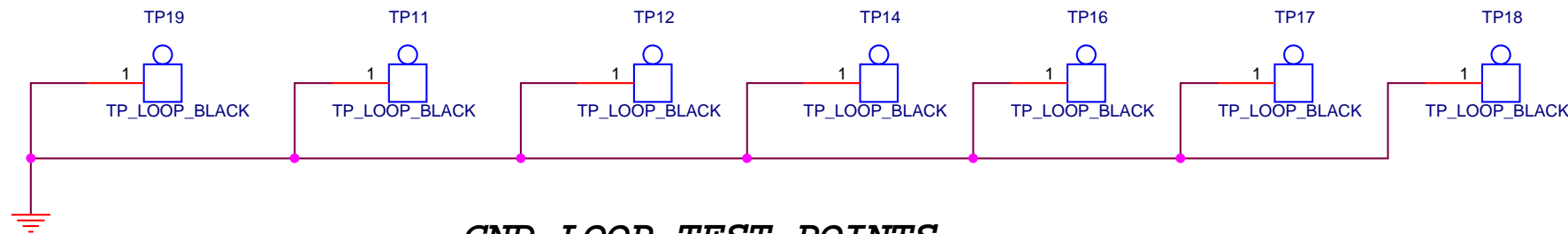
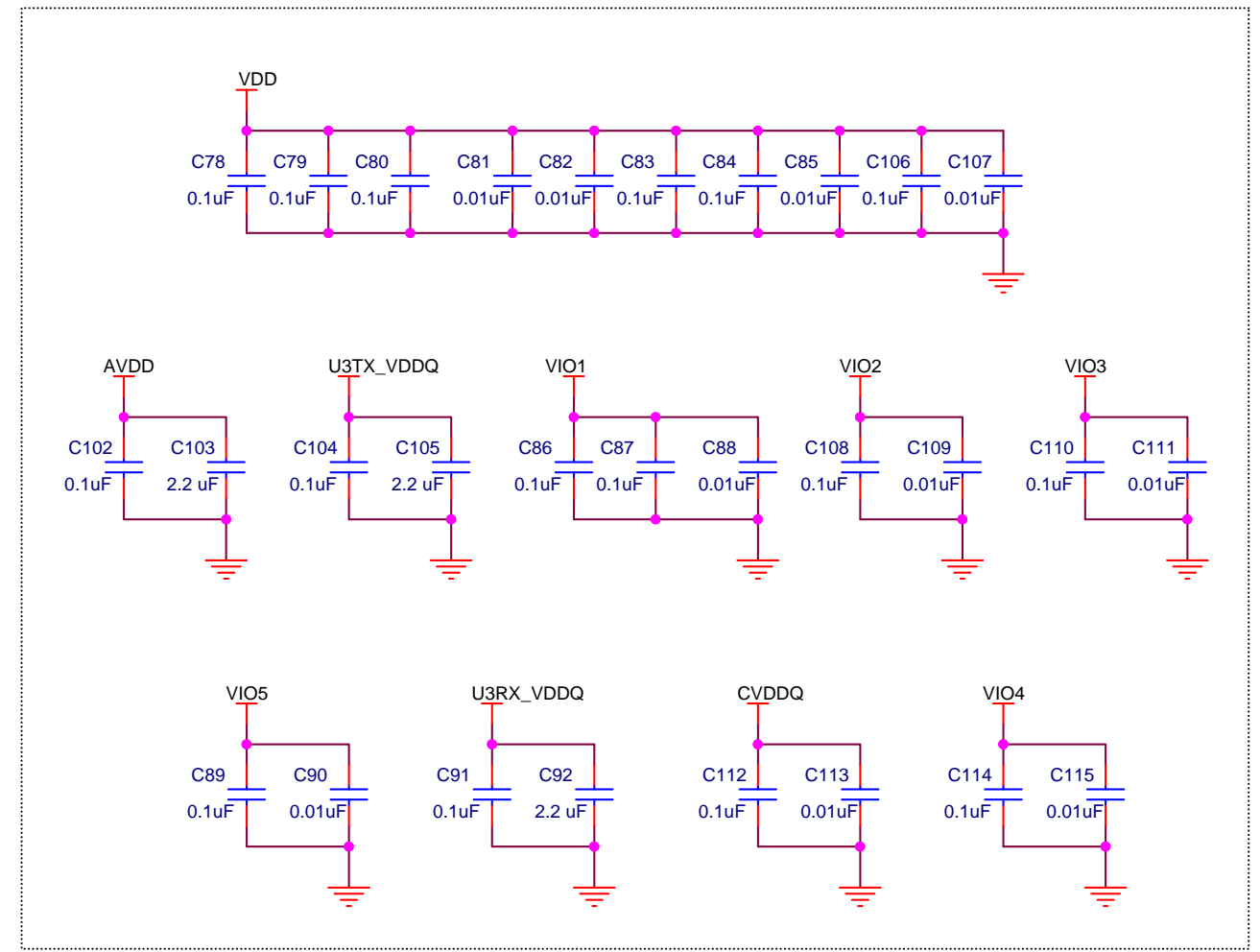
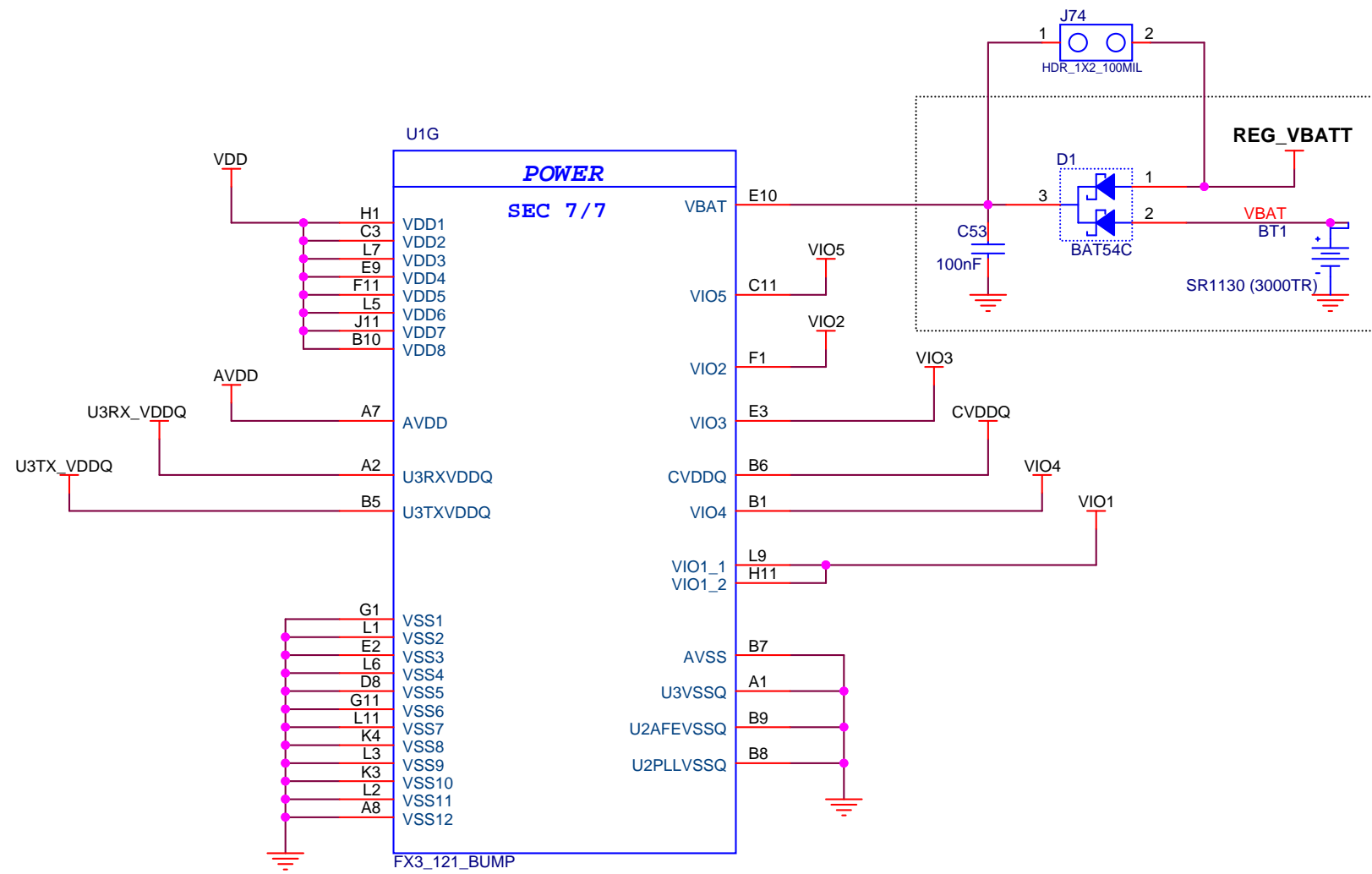

GND LOOP TEST POINTS

| | | |
|----------------------|------------------------------|----------------|
| Title | | |
| FX3 DVK DEVICE BOARD | | |
| Size | Document Number | Rev |
| B | 630-60013-01 REV03 | 3.0 |
| Date: | Thursday, September 08, 2011 | Sheet 10 of 14 |

5V - DC INPUT POWER

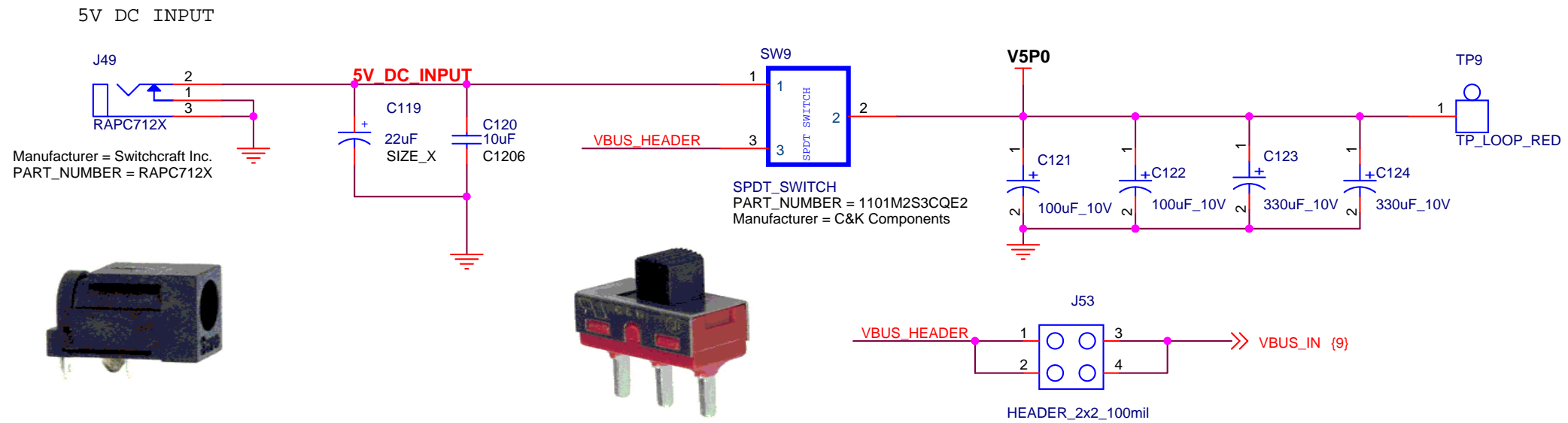

3.3V @ 1.5A REGULATOR

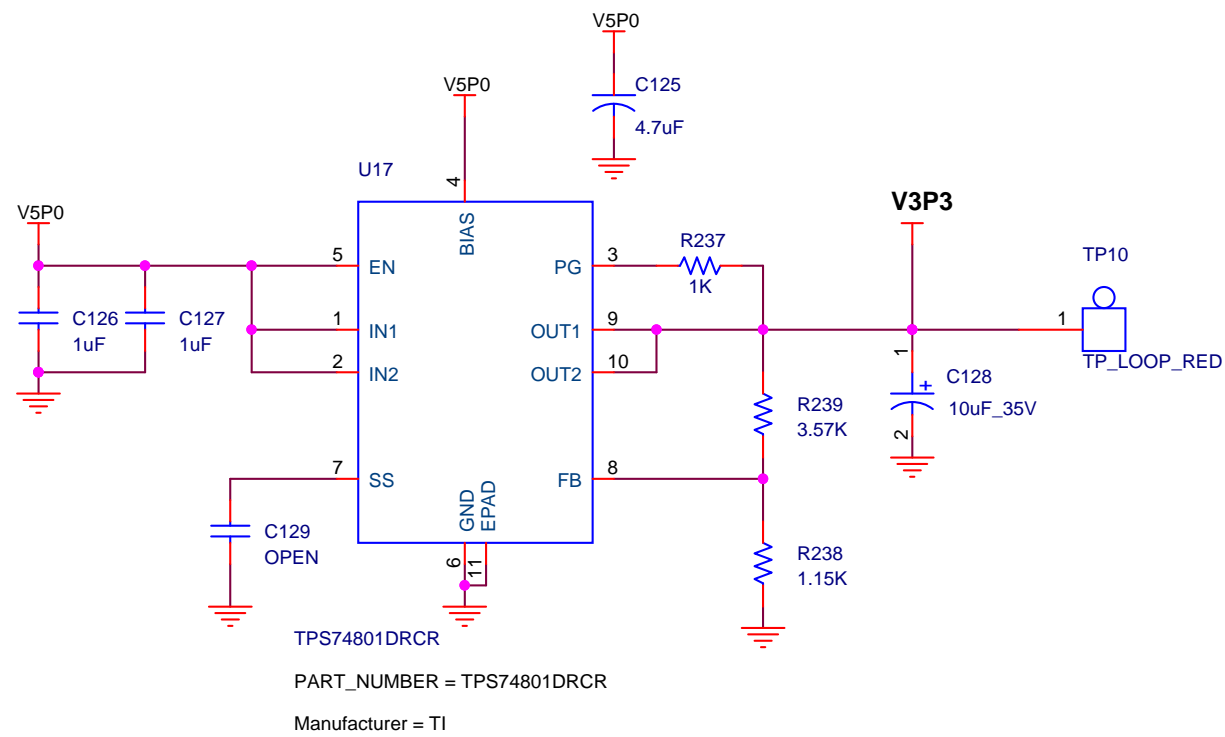

2.5V @ 1A REGULATOR

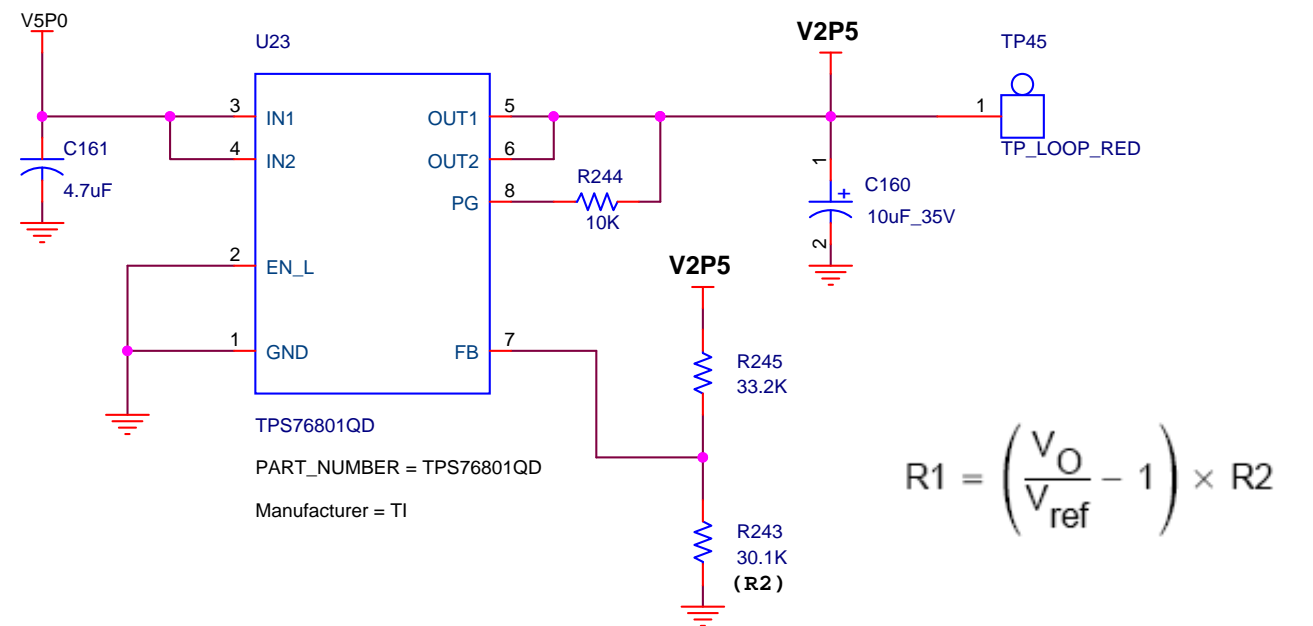

| | | |
|----------------------|---------------------------------------|----------------|
| Title | | |
| FX3 DVK DEVICE BOARD | | |
| Size B | Document Number 630-60013-01 REV03 | Rev 3.0 |
| Date: | Thursday, September 08, 2011 | Sheet 11 of 14 |

1.2V @ 1A REGULATOR

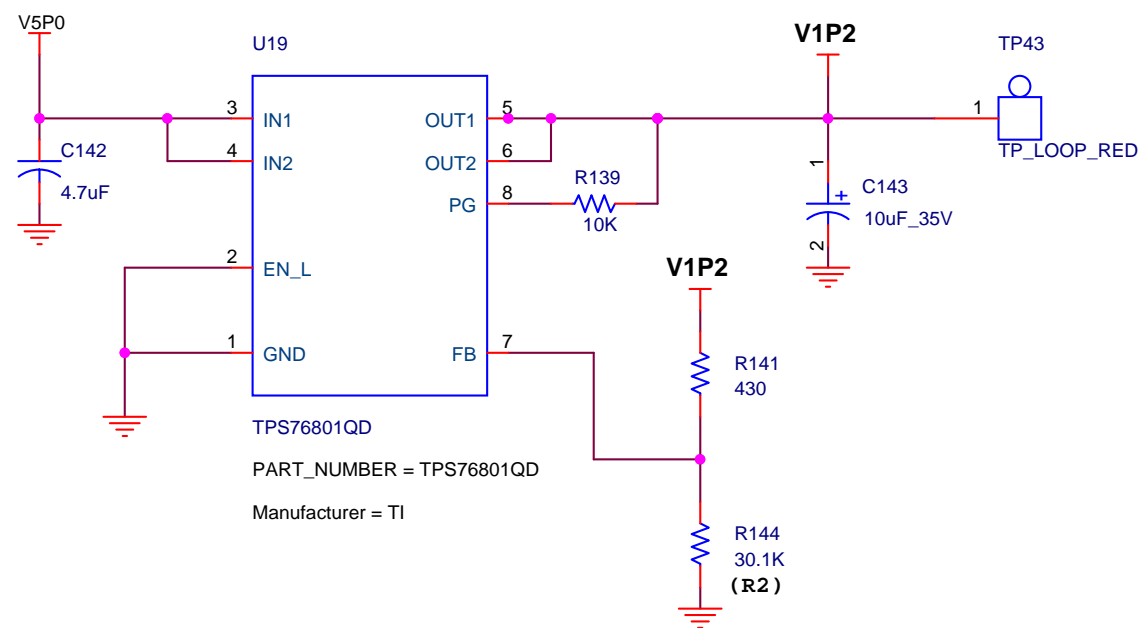

1.8V @ 1A REGULATOR

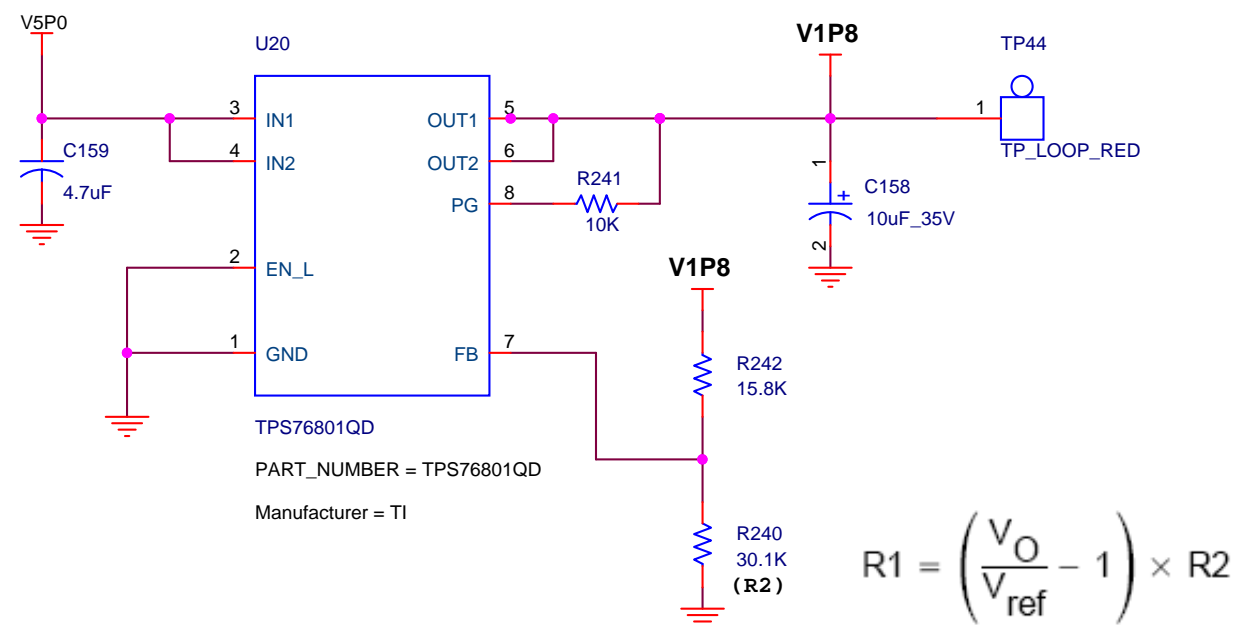

| | | |
|----------------------|------------------------------|----------------|
| Title | | |
| FX3 DVK DEVICE BOARD | | |
| Size | Document Number | Rev |
| B | 630-60013-01 REV03 | 3.0 |
| Date: | Thursday, September 08, 2011 | Sheet 12 of 14 |

VIO1

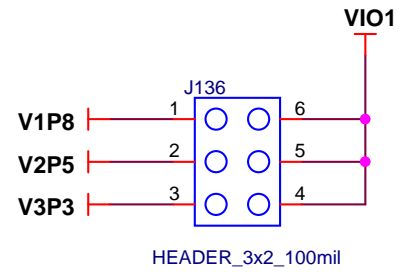

VIO2

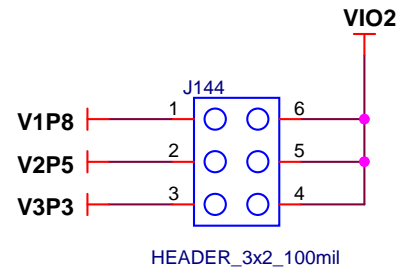

VIO3

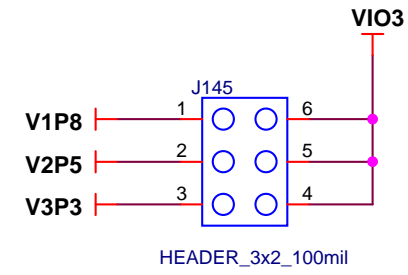

VIO4

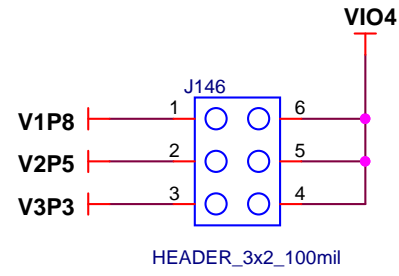

VIO5

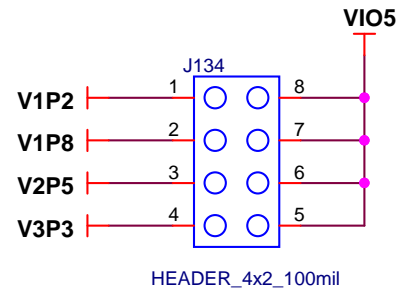

VDD,SRAM_VDD,EFVDDQ

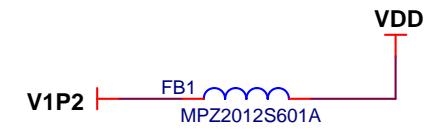

CVDDQ

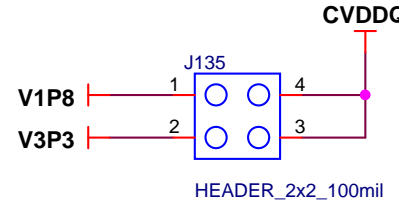

REG_VBATT

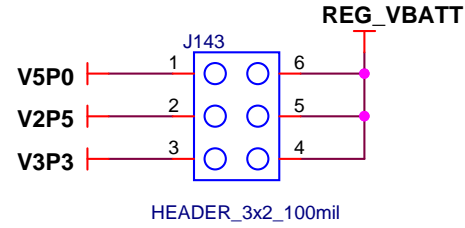

AVDD

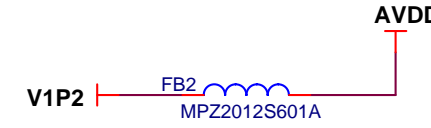

U3TX_VDDQ

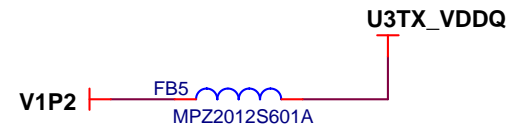

U3RX_VDDQ

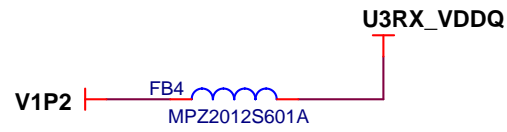

| | | |
|----------------------|------------------------------|----------------|
| Title | | |
| FX3 DVK DEVICE BOARD | | |
| Size | Document Number | Rev |
| B | 630-60013-01 REV03 | 3.0 |
| Date: | Thursday, September 08, 2011 | Sheet 13 of 14 |

POWER LED

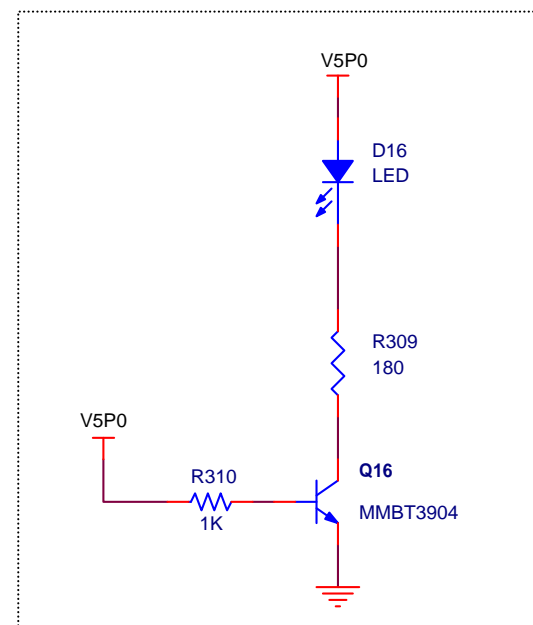
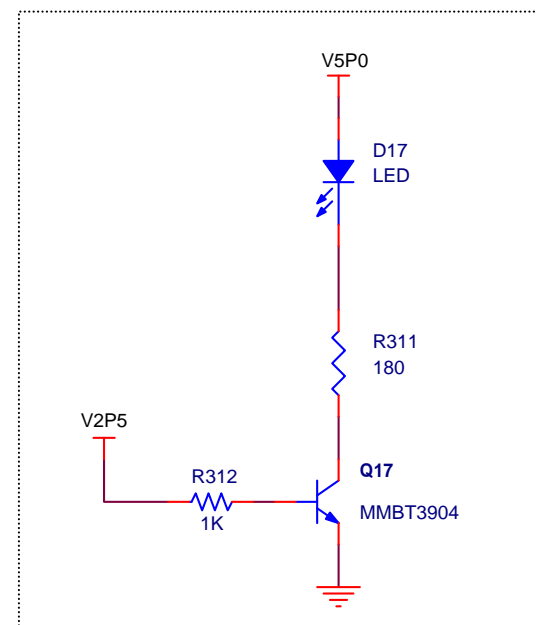
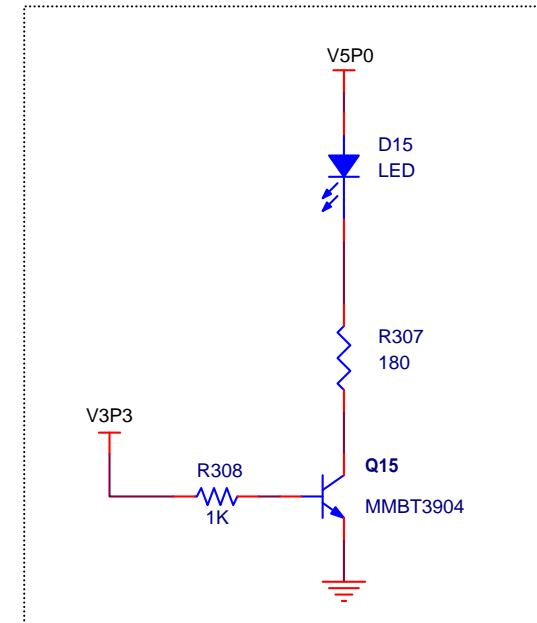
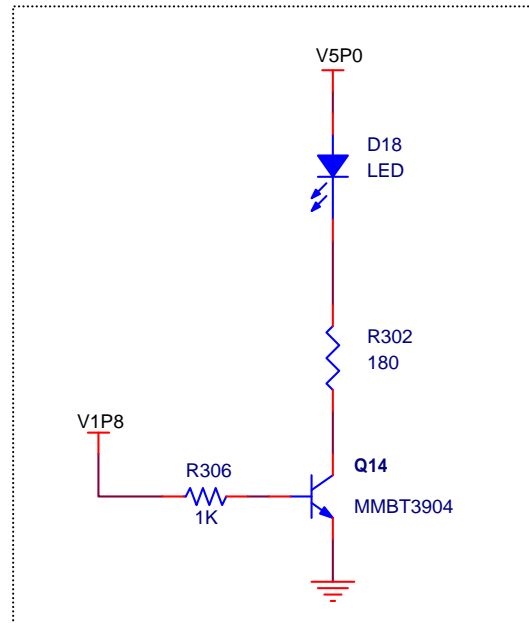
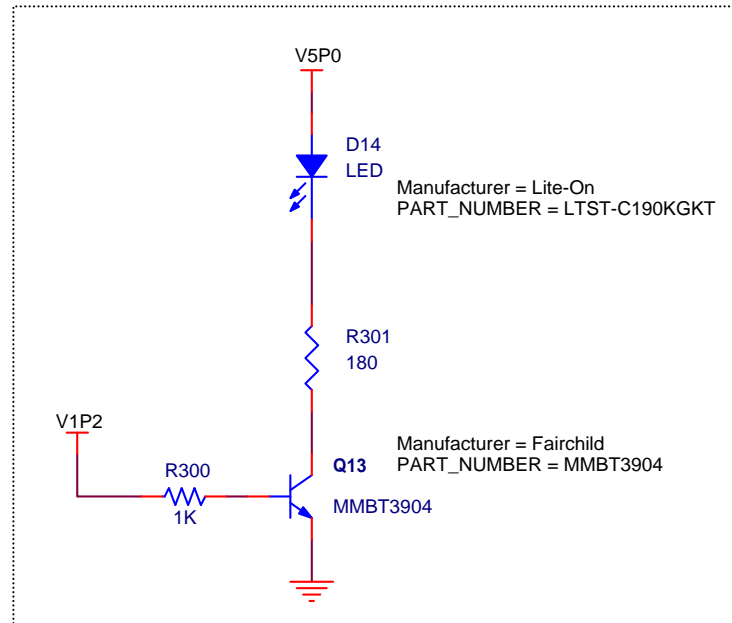

| | | |
|----------------------|------------------------------|----------------|
| Title | | |
| FX3 DVK DEVICE BOARD | | |
| Size | Document Number | Rev |
| B | 630-60013-01 REV03 | 3.0 |
| Date: | Thursday, September 08, 2011 | Sheet 14 of 14 |