

Radio Frequency Physical Layer (RF PHY)

Bluetooth® Test Suite

- **Revision:** RF-PHY.TS.5.1.1
- **Revision Date:** 2019-08-01
- **Group Prepared By:** BTI
- **Feedback Email:** bti-main@bluetooth.org



This document, regardless of its title or content, is not a Bluetooth Specification subject to the licenses granted by the Bluetooth SIG Inc. ("Bluetooth SIG") and its members under the Bluetooth Patent/Copyright License Agreement and Bluetooth Trademark License Agreement.

THIS DOCUMENT IS PROVIDED "AS IS" AND BLUETOOTH SIG, ITS MEMBERS, AND THEIR AFFILIATES MAKE NO REPRESENTATIONS OR WARRANTIES AND DISCLAIM ALL WARRANTIES, EXPRESS OR IMPLIED, INCLUDING ANY WARRANTY OF MERCHANTABILITY, TITLE, NON-INFRINGEMENT, FITNESS FOR ANY PARTICULAR PURPOSE, THAT THE CONTENT OF THIS DOCUMENT IS FREE OF ERRORS.

TO THE EXTENT NOT PROHIBITED BY LAW, BLUETOOTH SIG, ITS MEMBERS, AND THEIR AFFILIATES DISCLAIM ALL LIABILITY ARISING OUT OF OR RELATING TO USE OF THIS DOCUMENT AND ANY INFORMATION CONTAINED IN THIS DOCUMENT, INCLUDING LOST REVENUE, PROFITS, DATA OR PROGRAMS, OR BUSINESS INTERRUPTION, OR FOR SPECIAL, INDIRECT, CONSEQUENTIAL, INCIDENTAL OR PUNITIVE DAMAGES, HOWEVER CAUSED AND REGARDLESS OF THE THEORY OF LIABILITY, AND EVEN IF BLUETOOTH SIG, ITS MEMBERS, OR THEIR AFFILIATES HAVE BEEN ADVISED OF THE POSSIBILITY OF SUCH DAMAGES.

This document is proprietary to Bluetooth SIG. This document may contain or cover subject matter that is intellectual property of Bluetooth SIG and its members. The furnishing of this document does not grant any license to any intellectual property of Bluetooth SIG or its members.

This document is subject to change without notice.

Copyright © 2009–2019 by Bluetooth SIG, Inc. The Bluetooth word mark and logos are owned by Bluetooth SIG, Inc. Other third-party brands and names are the property of their respective owners.



Contents

1	Scope	6
2	References, Definitions, and Abbreviations	7
2.1	References	7
3	Test Suite Structure (TSS)	8
3.1	Test Strategy	8
3.2	Test Groups	8
3.2.1	Protocol Groups	8
3.2.2	Test Group	8
4	Test Cases	9
4.1	Introduction	9
4.1.1	Test Case Identification Conventions	9
4.1.2	Conformance	9
4.2	Common Test Case Conditions	10
4.3	Pass/Fail Verdict Conventions	10
4.4	Transmitter Tests (TRM)	10
4.4.1	RF-PHY/TRM/BV-01-C [Output power]	10
4.4.2	RF-PHY/TRM/BV-03-C [In-band emissions, uncoded data at 1 Ms/s]	11
4.4.3	RF-PHY/TRM/BV-05-C [Modulation Characteristics, uncoded data at 1 Ms/s]	13
4.4.4	RF-PHY/TRM/BV-06-C [Carrier frequency offset and drift, uncoded data at 1 Ms/s]	15
4.4.5	RF-PHY/TRM/BV-08-C [In-band emissions at 2 Ms/s]	18
4.4.6	RF-PHY/TRM/BV-09-C [Stable Modulation Characteristics, uncoded data at 1 Ms/s]	20
4.4.7	RF-PHY/TRM/BV-10-C [Modulation Characteristics at 2 Ms/s]	20
4.4.8	RF-PHY/TRM/BV-11-C [Stable Modulation Characteristics at 2 Ms/s]	21
4.4.9	RF-PHY/TRM/BV-12-C [Carrier frequency offset and drift at 2 Ms/s]	22
4.4.10	RF-PHY/TRM/BV-13-C [Modulation Characteristics, LE Coded (S=8)]	23
4.4.11	RF-PHY/TRM/BV-14-C [Carrier frequency offset and drift, LE Coded (S=8)]	25
4.4.12	RF-PHY/TRM/BV-15-C [Output power, With Constant Tone Extension]	27
4.4.13	RF-PHY/TRM/BV-16-C [Carrier frequency offset and drift, uncoded data at 1 Ms/s, Constant Tone Extension]	28
4.4.14	RF-PHY/TRM/BV-17-C [Carrier frequency offset and drift at 2 Ms/s, Constant Tone Extension]	32
4.4.15	Tx Power Stability, AoD Transmitter	33
4.4.15.1	RF-PHY/TRM/PS/BV-01-C [Tx Power Stability, AoD Transmitter at 1 Ms/s with 2 μ s Switching Slot]	34
4.4.15.2	RF-PHY/TRM/PS/BV-02-C [Tx Power Stability, AoD Transmitter at 1 Ms/s with 1 μ s Switching Slot]	34
4.4.15.3	RF-PHY/TRM/PS/BV-03-C [Tx Power Stability, AoD Transmitter at 2 Ms/s with 2 μ s Switching Slot]	34
4.4.15.4	RF-PHY/TRM/PS/BV-04-C [Tx Power Stability, AoD Transmitter at 2 Ms/s with 1 μ s Switching Slot]	34
4.4.16	Antenna switching integrity, AoD Transmitter	35
4.4.16.1	RF-PHY/TRM/ASI/BV-05-C [Antenna switching integrity, AoD Transmitter at 1 Ms/s with 2 μ s Switching Slot]	36
4.4.16.2	RF-PHY/TRM/ASI/BV-06-C [Antenna switching integrity, AoD Transmitter at 1 Ms/s with 1 μ s Switching Slot]	36
4.4.16.3	RF-PHY/TRM/ASI/BV-07-C [Antenna switching integrity, AoD Transmitter at 2 Ms/s with 2 μ s Switching Slot]	36
4.4.16.4	RF-PHY/TRM/ASI/BV-08-C [Antenna switching integrity, AoD Transmitter at 2 Ms/s with 1 μ s Switching Slot]	36



4.5	Receiver Tests (RCV)	36
4.5.1	RF-PHY/RCV/BV-01-C [Receiver sensitivity, uncoded data at 1 Ms/s].....	36
4.5.2	RF-PHY/RCV/BV-03-C [C/I and Receiver Selectivity Performance, uncoded data at 1 Ms/s]	38
4.5.3	RF-PHY/RCV/BV-04-C [Blocking Performance, uncoded data at 1 Ms/s]	41
4.5.4	RF-PHY/RCV/BV-05-C [Intermodulation Performance, uncoded data at 1 Ms/s]	43
4.5.5	RF-PHY/RCV/BV-06-C [Maximum input signal level, uncoded data at 1 Ms/s]	45
4.5.6	RF-PHY/RCV/BV-07-C [PER Report Integrity, uncoded data at 1 Ms/s]	46
4.5.7	RF-PHY/RCV/BV-08-C [Receiver sensitivity at 2 Ms/s]	47
4.5.8	RF-PHY/RCV/BV-09-C [C/I and Receiver Selectivity Performance at 2 Ms/s].....	48
4.5.9	RF-PHY/RCV/BV-10-C [Blocking performance at 2 Ms/s]	50
4.5.10	RF-PHY/RCV/BV-11-C [Intermodulation performance at 2 Ms/s]	51
4.5.11	RF-PHY/RCV/BV-12-C [Maximum input signal level at 2 Ms/s].....	53
4.5.12	RF-PHY/RCV/BV-13-C [PER Report Integrity at 2 Ms/s].....	53
4.5.13	RF-PHY/RCV/BV-14-C [Receiver Sensitivity, uncoded data at 1 Ms/s, Stable Modulation Index].....	54
4.5.14	RF-PHY/RCV/BV-15-C [C/I and Receiver Selectivity Performance, uncoded data at 1 Ms/s, Stable Modulation Index].....	55
4.5.15	RF-PHY/RCV/BV-16-C [Blocking Performance, uncoded data at 1 Ms/s, Stable Modulation Index]	56
4.5.16	RF-PHY/RCV/BV-17-C [Intermodulation Performance, uncoded data at 1 Ms/s, Stable Modulation Index]	56
4.5.17	RF-PHY/RCV/BV-18-C [Maximum input signal level, uncoded data at 1 Ms/s, Stable Modulation Index]	57
4.5.18	RF-PHY/RCV/BV-19-C [PER Report Integrity, uncoded data at 1 Ms/s, Stable Modulation Index]	57
4.5.19	RF-PHY/RCV/BV-20-C [Receiver sensitivity at 2 Ms/s, Stable Modulation Index].....	58
4.5.20	RF-PHY/RCV/BV-21-C [C/I and Receiver Selectivity Performance at 2 Ms/s, Stable Modulation Index]	59
4.5.21	RF-PHY/RCV/BV-22-C [Blocking performance at 2 Ms/s, Stable Modulation Index]	59
4.5.22	RF-PHY/RCV/BV-23-C [Intermodulation performance at 2 Ms/s, Stable Modulation Index].....	60
4.5.23	RF-PHY/RCV/BV-24-C [Maximum input signal level at 2 Ms/s, Stable Modulation Index].....	60
4.5.24	RF-PHY/RCV/BV-25-C [PER Report Integrity at 2 Ms/s, Stable Modulation Index].....	61
4.5.25	RF-PHY/RCV/BV-26-C [Receiver sensitivity, LE Coded (S=2)]	62
4.5.26	RF-PHY/RCV/BV-27-C [Receiver sensitivity, LE Coded (S=8)]	62
4.5.27	RF-PHY/RCV/BV-28-C [C/I and Receiver Selectivity Performance, LE Coded (S=2)]	63
4.5.28	RF-PHY/RCV/BV-29-C [C/I and Receiver Selectivity Performance, LE Coded (S=8)]	66
4.5.29	RF-PHY/RCV/BV-30-C [PER Report Integrity, LE Coded (S=2)].....	68
4.5.30	RF-PHY/RCV/BV-31-C [PER Report Integrity, LE Coded (S=8)].....	69
4.5.31	RF-PHY/RCV/BV-32-C [Receiver sensitivity, LE Coded (S=2), Stable Modulation Index].....	69
4.5.32	RF-PHY/RCV/BV-33-C [Receiver sensitivity, LE Coded (S=8), Stable Modulation Index].....	70
4.5.33	RF-PHY/RCV/BV-34-C [C/I and Receiver Selectivity Performance, LE Coded (S=2), Stable Modulation Index]	72
4.5.34	RF-PHY/RCV/BV-35-C [C/I and Receiver Selectivity Performance, LE Coded (S=8), Stable Modulation Index]	72
4.5.35	RF-PHY/RCV/BV-36-C [PER Report Integrity, LE Coded (S=2), Stable Modulation Index]	73
4.5.36	RF-PHY/RCV/BV-37-C [PER Report Integrity, LE Coded (S=8), Stable Modulation Index]	73
4.5.37	IQ Samples Coherency, AoD Receiver.....	74
4.5.37.1	RF-PHY/RCV/IQC/BV-01-C [IQ Samples Coherency, AoD Receiver at 1 Ms/s with 2 μ s Slot].....	75
4.5.37.2	RF-PHY/RCV/IQC/BV-02-C [IQ Samples Coherency, AoD Receiver at 1 Ms/s with 1 μ s Slot].....	75
4.5.37.3	RF-PHY/RCV/IQC/BV-03-C [IQ Samples Coherency, AoD Receiver at 2 Ms/s with 2 μ s Slot].....	75
4.5.37.4	RF-PHY/RCV/IQC/BV-04-C [IQ Samples Coherency, AoD Receiver at 2 Ms/s with 1 μ s Slot].....	75
4.5.38	IQ Samples Coherency, AoA Receiver	75
4.5.38.1	RF-PHY/RCV/IQC/BV-05-C [IQ Samples Coherency, AoA Receiver at 1 Ms/s with 2 μ s Slot]	77
4.5.38.2	RF-PHY/RCV/IQC/BV-06-C [IQ Samples Coherency, AoA Receiver at 2 Ms/s with 2 μ s Slot]	77
4.5.39	IQ Samples Dynamic Range, AoD Receiver.....	77



4.5.39.1	RF-PHY/RCV/IQDR/BV-07-C [IQ Samples Dynamic Range, AoD Receiver at 1 Ms/s with 2 μ s Slot]	79
4.5.39.2	RF-PHY/RCV/IQDR/BV-08-C [IQ Samples Dynamic Range, AoD Receiver at 1 Ms/s with 1 μ s Slot]	79
4.5.39.3	RF-PHY/RCV/IQDR/BV-09-C [IQ Samples Dynamic Range, AoD Receiver at 2 Ms/s with 2 μ s Slot]	79
4.5.39.4	RF-PHY/RCV/IQDR/BV-10-C [IQ Samples Dynamic Range, AoD Receiver at 2 Ms/s with 1 μ s Slot]	79
4.5.40	IQ Samples Dynamic Range, AoA Receiver	79
4.5.40.1	RF-PHY/RCV/IQDR/BV-11-C [IQ Samples Dynamic Range, AoA Receiver at 1 Ms/s with 2 μ s Slot]	81
4.5.40.2	RF-PHY/RCV/IQDR/BV-12-C [IQ Samples Dynamic Range, AoA Receiver at 2 Ms/s with 2 μ s Slot]	81
4.6	Test Setups Examples	81
4.6.1	Test Equipment Setup for AoD Receiver	81
4.6.2	Test Equipment Setup for AoA Receiver or AoD Transmitter	82
5	Test Case Mapping	83
6	Appendix	86
6.1	Reference Signal Definition	86
6.2	Frequencies for Testing	87
6.2.1	Operating Frequency Band	87
6.2.2	Frequencies for Testing: Peripheral and Central Devices	87
6.2.3	Frequencies for Testing: Broadcaster and Observer Devices	89
6.3	Normal Operating Conditions (NOC)	91
6.3.1	Normal Temperature and Air Humidity	91
6.3.2	Nominal Supply Voltage	91
6.4	Packet Error Rate / Bit Error Rate Measurements	91
6.4.1	PER Test Definition	91
6.4.2	BER to PER Mapping	92
6.5	Definition of the Position of Bit p ₀	102
6.6	Measurement Uncertainty	102
6.7	Packet Lengths	103
6.8	Number of Valid IQ Sample Pairs	104
6.8.1	Maximum Number of Packets for IQ Coherency Measurements	105
7	Revision History and Contributors	107

1 Scope

This Bluetooth document contains the Test Suite Structure (TSS) and Test Cases (TC) to test the Bluetooth low energy RF PHY. The objective of this Test Suite is to provide a basis for interoperability for a device or submodule giving a high probability of air interface interoperability between different manufacturers' implementations.



2 References, Definitions, and Abbreviations

2.1 References

This Bluetooth document incorporates, by dated or undated reference, provisions from other publications. These normative references are cited at the appropriate places in the text and the publications are listed hereinafter. Additional definitions and abbreviations can be found in [1] and [2]. Mathematical conventions used in this document comply with the definitions given in given in [1].

- [1] Bluetooth Test Strategy and Terminology Overview
- [2] Bluetooth Specification, v4.0 or later, Vol. 6, Part A; Physical Layer Specification
- [3] ICS Proforma for Bluetooth Low Energy RF PHY, v1.0 or later
- [4] Bluetooth Specification v4.0 or later, Vol. 6, Part F; Direct Test Mode
- [5] IXIT Proforma for Bluetooth Low Energy Conformance Test Suites, v4.2 or later
- [6] Bluetooth Core Specification Addendum 5, Volume 6, Part A; Physical Layer Specification
- [7] Bluetooth Specification v5.0 or later, Vol. 6, Part A; Physical Layer Specification
- [8] Bluetooth Specification v5.1 or later, Vol. 6, Part A; Physical Layer Specification
- [9] Bluetooth Specification v5.1 or later, Vol. 6, Part F; Direct Test Mode
- [10] IXIT Proforma for Bluetooth Low Energy Conformance Test Suites, v5.1 or later

3 Test Suite Structure (TSS)

3.1 Test Strategy

The two primary objectives of the Bluetooth low energy RF PHY test strategy are:

- To ensure interoperability between all Bluetooth low energy devices in the marketplace
- To verify that a basic level of system performance is guaranteed for all Bluetooth low energy products

The objectives are met by performing a series of functional and parametric tests over the allowed range of parameter variation.

With these objectives in mind, the creation of the test strategy also takes into account ways to reduce the test execution time required for product qualification.

In order to avoid qualification test redundancy, telecommunication regulatory motivated tests are not included in the Bluetooth low energy qualification requirements. Meeting the regulatory requirements is guaranteed by passing mandatory telecommunication regulatory tests prior to, or followed by Bluetooth low energy qualification.

3.2 Test Groups

The test groups are organized in two levels. The first level defines the protocol groups representing the protocol services. The second level separates the protocol services in functional modules. All tests are Capability tests as defined in the standard ISO subgroups.

3.2.1 Protocol Groups

The protocol group identifies the kind of test for Bluetooth low energy RF PHY test purposes:

- Transmitter
- Receiver

3.2.2 Test Group

The test group used for the Bluetooth low energy RF PHY test suite is the capability group. This test group provides testing of the major IUT capabilities aiming to ensure that the claimed capabilities are correctly supported, according to the ICS.



4 Test Cases

4.1 Introduction

4.1.1 Test Case Identification Conventions

Test cases shall be assigned unique identifiers per the conventions in [1]. The convention used here is **<spec abbreviation>/<IUT role>/<class>/<feat>/<func>/<subfunc>/<cap>/<xx>-<nn>-<y>**.

Bolded ID parts shall appear in the order prescribed. Non-bolded ID parts (if applicable) shall appear between the bolded parts. The order of the non-bolded parts may vary from test suite to test suite, but shall be consistent within each individual test suite.

Identifier Abbreviation	Spec Identifier <spec abbreviation>
RF-PHY	RF-PHY Specification
Identifier Abbreviation	Feature Identifier <feat>
RCV	Receiver Tests
TRM	Transmitter Tests
IQC	IQ samples Coherency
PS	Power Stability
IQDR	IQ samples Dynamic Range

Table 4.1: RF PHY TC Naming Conventions

4.1.2 Conformance

When conformance is claimed, all capabilities indicated as mandatory for this Specification shall be supported in the specified manner (process-mandatory). This also applies for all optional and conditional capabilities for which support is indicated. All mandatory capabilities, and optional and conditional capabilities for which support is indicated, are subject to verification as part of the Bluetooth Qualification Program.

The Bluetooth Qualification Program may employ tests to verify implementation robustness. The level of implementation robustness that is verified varies from one Specification to another and may be revised for cause based on interoperability issues found in the market.

Such tests may verify:

- That claimed capabilities may be used in any order and any number of repetitions that is not excluded by the Specification, OR
- That capabilities enabled by the implementations are sustained over durations expected by the use case, OR
- That the implementation gracefully handles any quantity of data expected by the use case, OR



- That in cases where more than one valid interpretation of the Specification exist, the implementation complies with at least one interpretation and gracefully handles other interpretations OR
- That the implementation is immune to attempted security exploits.

A single execution of each of the required tests is required in order to constitute a pass verdict. However, it is noted that in order to provide a foundation for interoperability, it is necessary that a qualified implementation consistently and repeatedly pass any of the applicable tests.

In any case, where a member finds an issue with the Test Plan Generator, the Test Case as described in the Test Suite, or with the Test System utilized, the Member is required to notify the responsible party via an errata request such that the issue may be addressed.

4.2 Common Test Case Conditions

Unless stated otherwise in individual test cases the following applies throughout this test suite:

1. The IUT is connected to the tester via a 50Ω connector. If there is no antenna interface, a temporary 50Ω interface or a suitable coupling device may be used.
2. The test case is to be performed at normal operating conditions.

4.3 Pass/Fail Verdict Conventions

Each test case has an Expected Outcome section, which outlines all the detailed pass criteria conditions that shall be met by the IUT to merit a Pass Verdict.

The convention in this test suite is that, unless there is a specific set of fail conditions outlined in the test case, then IUT fails the test case as soon one of the pass criteria conditions cannot be met and in case this occurs the outcome of the test shall be the Fail Verdict.

4.4 Transmitter Tests (TRM)

4.4.1 RF-PHY/TRM/BV-01-C [Output power]

- Test Purpose

This test verifies the maximum peak and average power emitted from the IUT.
- Reference

[2] Chapter 3

[6] Chapter 3
- Initial Condition
 - The IUT is set to direct TX mode at maximum output power. Whitening shall be turned off.
 - Frequency hopping off, fixed frequency
 - The value of MAX_TX_LENGTH (for which the TC is performed) is specified in Section 6.7.
- Test Procedure
 1. The IUT transmits LE test packets with PRBS9 payload (MAX_TX_LENGTH octets) . See [4] Section 4, “LE Test Packet Definition” for details.



2. The followings settings shall be used for the tester:

Center frequency	at the lowest frequency for testing as defined in Section 6.2.
Frequency span	Zero span
Resolution BW	3 MHz
Video BW	3 MHz
Detector	Peak
Mode	Clear/Write
Sweep time	Must cover at least one complete test packet
Trigger	RF (trigger on rising edge)

3. Upon packet transmission, the tester is triggered to make a sweep over the duration of one packet. The sweep shall start at the beginning of the first bit in the preamble.
4. The peak power value, P_{PK} , of the sweep is recorded.
5. The tester calculates average power P_{AVG} over at least 20 percent to 80 percent of the duration of the burst (position of p_0 defines the beginning of the burst; see Chapter 6.5 Definition of the Position of Bit p_0).
6. Steps 2–5 are repeated for the remaining frequencies defined in Section 6.2.

- Test Condition

Common Test Case Conditions defined in Section 4.2 apply.

- Expected Outcome

Pass Verdict

All measured values shall fulfill the following conditions:

$$PPK \leq (P_{AVG} + 3 \text{ dB})$$

AND

$-20 \text{ dBm} \leq P_{AVG} \leq +10 \text{ dBm}$ if the IUT is compliant to Core Specification v4.2 or earlier and not compliant to Core Specification Addendum 5 [6]

OR

$-20 \text{ dBm} \leq P_{AVG} \leq +20 \text{ dBm}$; otherwise

4.4.2 RF-PHY/TRM/BV-03-C [In-band emissions, uncoded data at 1 Ms/s]

- Test Purpose

This test verifies that the in-band spectral emissions are within limits at normal operating conditions when the transmitter is operating with uncoded data at 1 Ms/s.

- Reference

[2] Chapter 3.2



- Initial Condition
 - The IUT is set to direct TX mode at maximum output power. Whitening shall be turned off.
 - Frequency hopping off, fixed frequency
 - The value of MAX_TX_LENGTH (for which the TC is performed) is specified in Section 6.7.
- Test Procedure
 1. The IUT is set to receive at the lowest frequency for testing as defined in Section 6.2.
 2. The IUT transmits LE test packets with PRBS9 payload (MAX_TX_LENGTH octets). See [4], Section 4, "LE Test Packet Definition" for details.
 3. Set N:=0
 4. The followings settings shall be used for the tester:

Center frequency	2401 MHz + N MHz
Frequency span	1 MHz
Resolution BW	100 kHz
Video BW	300 kHz
Detector	Average
Mode	Maximum hold
Sweep time	100 ms
Number of sweeps	10

5. Measure the power levels, $P_{TX_N,i}$ at the following 10 frequencies: (2401 MHz + N MHz) - 450 kHz + i·100 kHz, where i=0...9
6. Calculate and record $PTX = \Sigma(P_{TX_N,i})$
7. Increase center frequency by 1 MHz; N:=N+1 AND skip to next frequency if the increased frequency equals to f_{TX} or " $f_{TX} - 1$ MHz" or " $f_{TX} + 1$ MHz".
8. Repeat steps 4–7 until the center frequency is 2481 MHz
9. Set the IUT transmit frequency (f_{TX}) to:
 10. The mid operating frequency as defined in Section 6.2 and
 11. The high operating frequency as defined in Section 6.2
12. Repeat steps 3–8 for both frequencies.

- Test Condition

Common Test Case Conditions defined in Section 4.2 apply.

- Expected Outcome

Pass Verdict

All measured values fulfill the following conditions:

$$P_{TX} \leq -20 \text{ dBm for } (f_{TX} \pm 2 \text{ MHz})$$

$$P_{TX} \leq -30 \text{ dBm for } (f_{TX} \pm [3 + n] \text{ MHz}); \text{ where } n=0,1,2,\dots$$



For each operating frequency, up to three bands of 1 MHz width (as defined in the measurement) can be exempted from the requirements. The excepted values shall however comply with an absolute value of $P_{TX} \leq -20$ dBm.

4.4.3 RF-PHY/TRM/BV-05-C [Modulation Characteristics, uncoded data at 1 Ms/s]

- Test Purpose

This test verifies that the modulation characteristics of the transmitted signal are correct when the transmitter is operating with uncoded data at 1 Ms/s.

- Reference

[2] Chapter 3.1

- Initial Condition

- The IUT is set to direct TX mode at maximum output power. Whitening shall be turned off.
- Frequency hopping off, fixed frequency
- The value of MAX_TX_LENGTH (for which the TC is performed) is specified in Section 6.7.

- Test Procedure

1. The IUT is set to transmit at the lowest frequency for testing as defined in Section 6.2.
2. The IUT transmits LE test packets with MAX_TX_LENGTH octet packet payload consisting of a repetitive sequence of 0F_{hex} octets (11110000_{bin} in transmission order). See [4], Section 4, “LE Test Packet Definition”, for details.
3. The followings settings shall be used for the tester:

Center frequency	lowest frequency for testing as defined in Section 6.2
Mode	FM demodulation
Demodulator filter BW	2 MHz (minimum)
Filter passband ripple	0.5dB peak-to-peak max. within ± 550 kHz
Trigger	RF (trigger on rising edge)

Recommended measurement channel filter minimum attenuator characteristics;

± 650 kHz	-3 dB
± 1 MHz	-14 dB
± 2 MHz	-44 dB

4. The payload is FM demodulated with the settings described in 3. The measurement shall start at the beginning of the fifth bit of the payload (See Figure 4.1 for description). The last four bits in the payload shall be disregarded (i.e. last bit in the measurement is the fourth bit in the MAX_TX_LENGTHth octet).
5. Each individual bit is to be oversampled at least 32 times. The sequence center frequency; $f1_{ccf}$ is calculated as the average frequency of all samples over each 00001111_{bin} sequence.



6. For the second, third, sixth and seventh bits in each 00001111bin sequence, the absolute value of the frequency offset from f_{1ccf} is recorded as Δf_{1max} . Δf_{1max} is defined as the average deviation for each individual bit. See Figure 4.2 for reference.
7. The average frequency value of all Δf_{1max} frequencies in a packet is calculated and recorded as Δf_{1avg} .
8. The IUT transmits LE test packets with MAX_TX_LENGTH octet payload consisting of a repetitive sequence of 55hex octets (10101010bin in transmission order). See [4], Section 4, "LE Test Packet Definition" for details.
9. The payload is FM demodulated with the settings described in 3. The measurement shall start at the beginning of the fifth bit in the payload field. The last four bits in the payload shall be disregarded (i.e. last bit in the measurement is the fourth bit in the MAX_TX_LENGTHth octet).
10. Each individual bit is to be oversampled at least 32 times. The sequence center frequency; f_{2ccf} is calculated as the average frequency of all samples over each 10101010bin sequence.
11. The maximum deviation from the sequence center frequency, f_{2ccf} is recorded as Δf_{2max} for each individual bit. See Figure 4.2 for reference.
12. The average frequency value of all Δf_{2max} frequencies in a packet is calculated and recorded as Δf_{2avg} .
13. Steps 2–12 are repeated for a minimum of 10 packets.
14. Steps 2–13 are repeated when the IUT is transmitting at the remaining frequencies defined in Section 6.2.

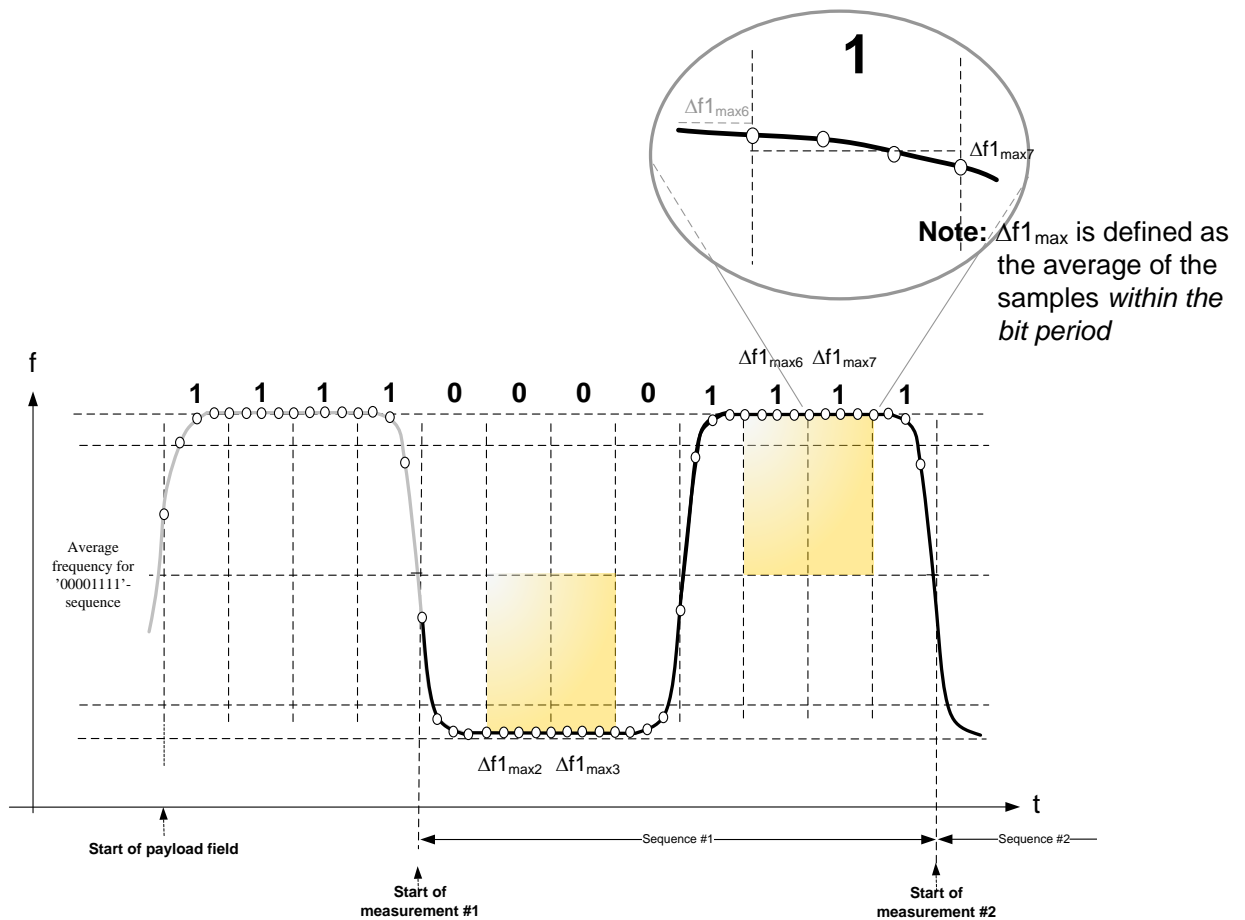


Figure 4.1: Frequency deviation measurement principle for 11110000-payload sequence

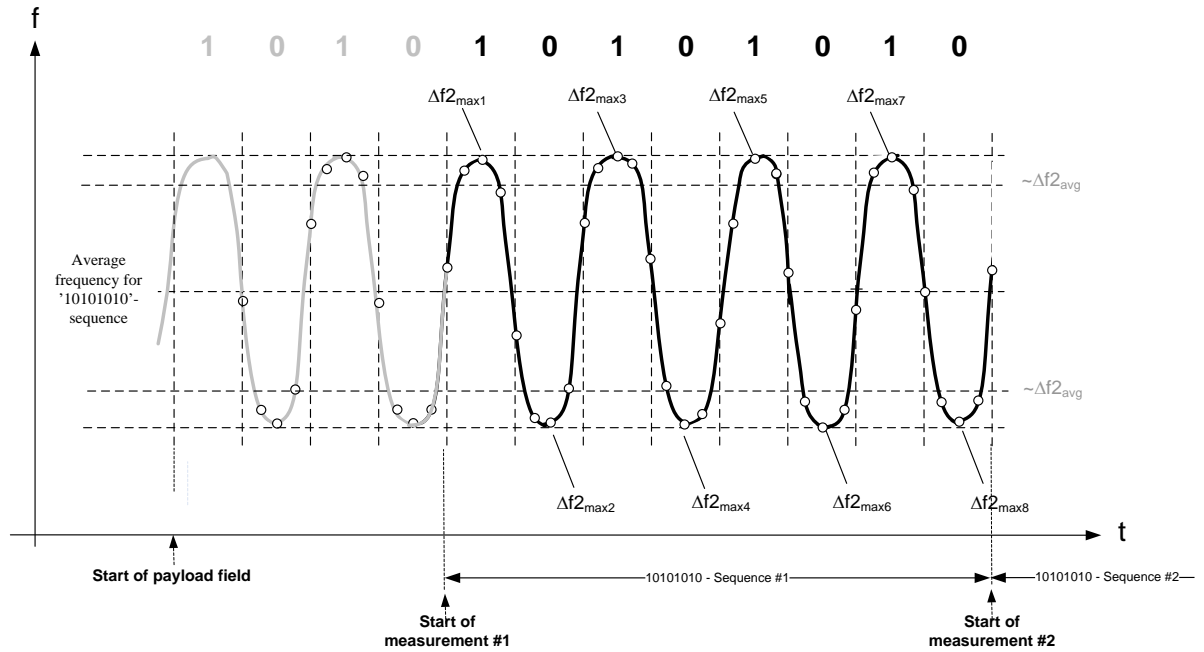


Figure 4.2: Frequency deviation measurement principle for 10101010-payload sequence

- Test Condition

Common Test Case Conditions defined in Section 4.2 apply.

- Expected Outcome

Pass Verdict

All measured values fulfill the following conditions at the low, medium and high frequencies:

$$225 \text{ kHz} \leq \Delta f_{1 \text{ avg}} \leq 275 \text{ kHz}$$

At least 99.9% of all $\Delta f_{2 \text{ max}}$ frequency values recorded over 10 LE test packets are greater than 185 kHz

$$\frac{\Delta f_{2 \text{ avg}}}{\Delta f_{1 \text{ avg}}} \geq 0.8$$

- Notes

To compensate for the statistical distribution of individual samples, the decision criteria is applied to 99.9 percent of the sample values.

4.4.4 RF-PHY/TRM/BV-06-C [Carrier frequency offset and drift, uncoded data at 1 Ms/s]

- Test Purpose

This test verifies that the carrier frequency offset and carrier drift of the transmitted signal with uncoded data at 1 Ms/s is within specified limits at normal operating conditions.

- Reference
 - [2] Chapter 3.3
- Initial Condition
 - The IUT is set to direct TX mode at maximum output power. Whitening shall be turned off.
 - Frequency hopping off, fixed frequency
 - The value of MAX_TX_LENGTH (for which the TC is performed) is specified in Section 6.7.
- Test Procedure
 1. The IUT is set to transmit at the lowest frequency for testing as defined in Section 6.2.
 2. The IUT transmits LE test packets with MAX_TX_LENGTH octet payload consisting of a repetitive sequence of 55hex octets (10101010bin in transmission order) in the payload . See [4], Section 4, “LE Test Packet Definition” for details.
 3. The followings settings shall be used for the tester:

Center frequency	lowest frequency for testing as defined in Section 6.2
Mode	FM demodulation
Demodulator filter BW	2 MHz (minimum)
Filter passband ripple	0.5 dB peak-to-peak max. within ± 550 kHz
Trigger	RF (trigger on rising edge)

Recommended measurement channel filter minimum attenuator characteristics:

± 650 kHz	-3 dB
± 1 MHz	-14 dB
± 2 MHz	-44 dB

4. The packet is FM demodulated with the settings described in step 3). The measurement is to be performed at the start of the preamble field in the transmitted packet. The tester integrates the frequency of the FM demodulated signal from the center of the first preamble bit to the center of the first bit following the 8th preamble bit, 8 bits in total. See Figure 4.3 for reference.
5. The integral sum in 4 is considered to be the initial carrier frequency of the IUT, and is recorded as f_0 .
6. Throughout the payload of the packet, the tester integrates the frequency of the FM demodulated signal in 10-bit intervals, starting at the second bit in the payload. The measurement is repeated until the end of the payload duration. The last 10-bit sequence should not overlap the CRC-field at the end of the packet. See Figure 4.4 for reference. The integral sums are recorded as f_n , where n is an integer from 1 to k . f_k represents the last integral sum before the start of the CRC field in the packet.
7. Steps 2–6 are repeated for a minimum of 10 packets.
8. Steps 2–7 are repeated when the IUT is transmitting at the remaining frequencies defined in Section 6.2.

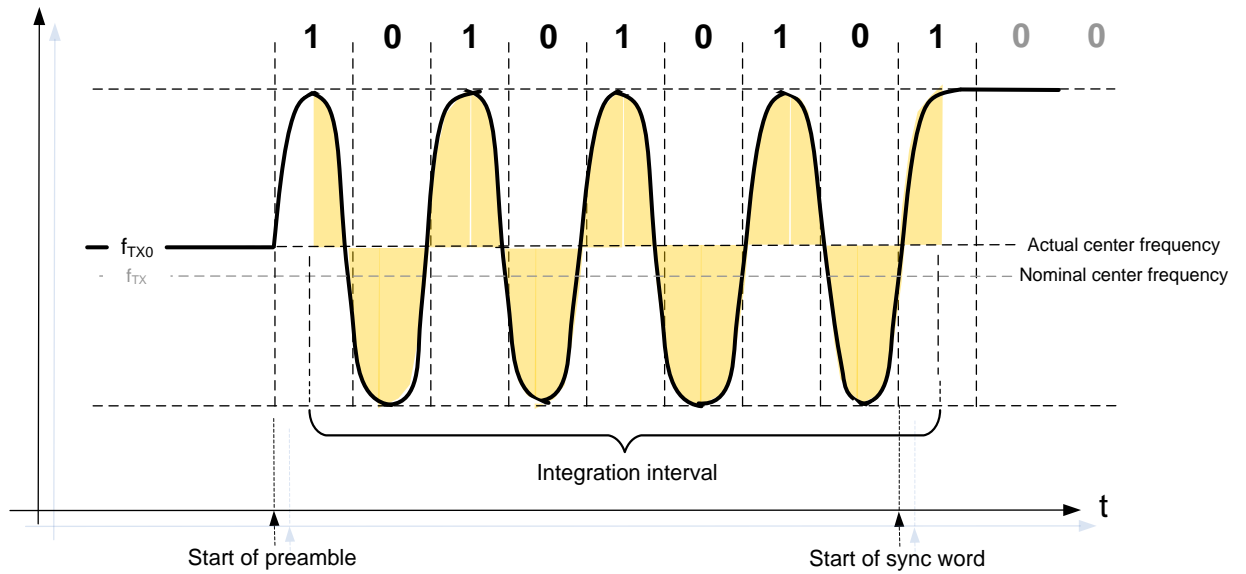


Figure 4.3: Initial frequency offset (f_0) measurement principle

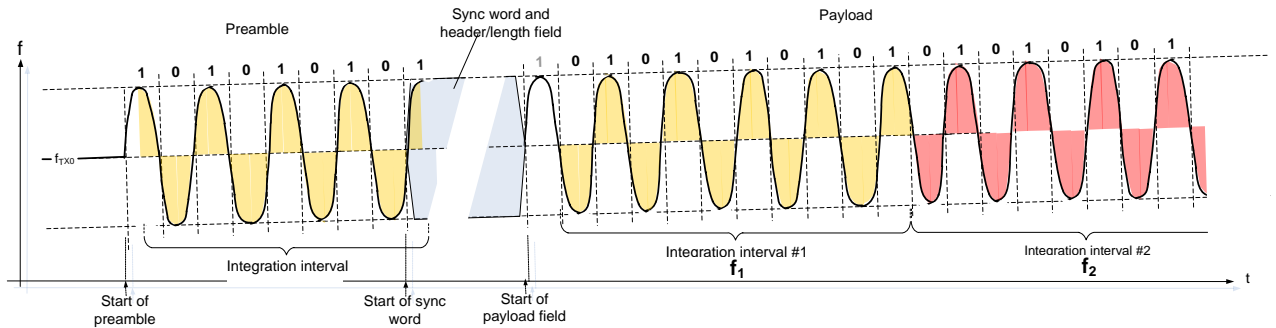


Figure 4.4: Frequency drift measurement principle

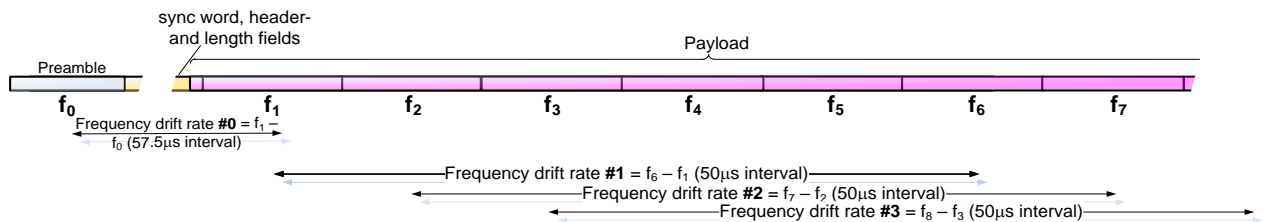


Figure 4.5: Frequency drift rate measurement principle

- Test Condition

Common Test Case Conditions defined in Section 4.2 apply.

- Expected Outcome

The maximum drift rate is 20kHz/50µs, anywhere in the packet. The maximum drift rate applies to the difference between any two 10-bit groups separated by 50µs within the payload field of the packet transmitted by the IUT. The requirement also applies to the frequency difference between the initial frequency measurement f_0 and the first payload frequency measurement f_1 . See Figure 4.5 for reference.

All measured values fulfill the following conditions at the low, medium and high frequencies.

Pass Verdict

$$f_{TX} - 150 \text{ kHz} \leq f_n \leq f_{TX} + 150 \text{ kHz}$$

where f_{TX} is the nominal transmit frequency and $n=0,1,2,3\dots k$

$$|f_0 - f_n| \leq 50 \text{ kHz}$$

where $n=2,3,4\dots k$

$$|f_1 - f_0| \leq 23 \text{ kHz and } |f_n - f_{n-5}|_{n=6,7,8\dots k} \leq 20 \text{ kHz}$$

In all of the above pass verdict requirements, f_k is the last frequency measurement before the CRC field.

4.4.5 RF-PHY/TRM/BV-08-C [In-band emissions at 2 Ms/s]

- Test Purpose

This test verifies that the in-band spectral emissions are within limits at normal operating conditions when the transmitter is operating at 2 Ms/s.

- Reference

[7] Chapter 3.2.2

- Initial Condition

The IUT is set to direct TX mode at maximum output power. Whitening shall be turned off.

Frequency hopping off, fixed frequency.

The value of MAX_TX_LENGTH_2M (for which the TC is performed) is specified in Section 6.7.

IUT is set for a symbol rate of 2 Ms/s.

- Test Procedure

1. The IUT is set to receive at the lowest frequency for testing as defined in Section 6.2.
2. The IUT transmits LE test packets with PRBS9 payload (MAX_TX_LENGTH_2M octets) at 2 Ms/s symbol rate. See [4], Section 4, "LE Test Packet Definition" for details.
3. Set N:=0

4. The followings settings shall be used for the tester:

Center frequency	2401 MHz + N MHz
Frequency span	1 MHz
Resolution BW	100 kHz
Video BW	300 kHz
Detector	Average
Mode	Maximum hold
Sweep time	100 ms
Number of sweeps	10

5. Measure the power levels, $P_{TX_N,i}$ at the following 10 frequencies: $(2401\text{MHz} + N \text{ MHz}) - 450\text{kHz} + i \cdot 100\text{kHz}$, where $i=0 \dots 9$
6. Calculate and record $P_{TX} = \sum(P_{TX_N,i})$
7. Increase center frequency by 1 MHz; $N:=N+1$ AND skip to next frequency if the increased frequency equals to f_{TX} or " $f_{TX} - 1\text{MHz}$ " or " $f_{TX} + 1\text{MHz}$ " or " $f_{TX} - 2\text{MHz}$ " or " $f_{TX} + 2\text{MHz}$ " or " $f_{TX} - 3\text{MHz}$ " or " $f_{TX} + 3\text{MHz}$ ".
8. Repeat steps 4–7 until the center frequency is 2481MHz
9. Set the IUT transmit frequency (f_{TX}) to:
 10. The mid operating frequency as defined in Section 6.2 and
 11. The high operating frequency as defined in Section 6.2
12. Repeat steps 3–8 for both frequencies.

- Test Condition

Common Test Case Conditions defined in Section 4.2 apply.

- Expected Outcome

Pass Verdict

All measured values fulfill the following conditions:

$$P_{TX} \leq -20 \text{ dBm for } (f_{TX} \pm 4 \text{ MHz})$$

$$P_{TX} \leq -20 \text{ dBm for } (f_{TX} \pm 5 \text{ MHz})$$

$$P_{TX} \leq -30 \text{ dBm for } (f_{TX} \pm [6 + n] \text{ MHz}); \text{ where } n=0,1,2 \dots$$

For each operating frequency, up to three bands of 1 MHz width (as defined in the measurement) can be exempted from the requirements. The excepted values shall however comply with an absolute value of $P_{TX} \leq -20 \text{ dBm}$.

4.4.6 RF-PHY/TRM/BV-09-C [Stable Modulation Characteristics, uncoded data at 1 Ms/s]

- Test Purpose

This test verifies the modulation characteristics are within limits to be considered a Stable Modulation Index when the transmitter is operating with uncoded data at 1 Ms/s.

- Reference

[6] Chapter 3.1.1

- Initial Condition

As for RF-PHY/TRM/BV-05-C (Modulation Characteristics, uncoded data at 1 Ms/s).

- Test Procedure

As for RF-PHY/TRM/BV-05-C (Modulation Characteristics, uncoded data at 1 Ms/s).

- Test Condition

Common Test Case Conditions defined in Section 4.2 apply.

- Expected Outcome

Pass Verdict

All measured values fulfill the following conditions at the low, medium and high frequencies:

$$247.5 \text{ kHz} \leq \Delta f_{1_{avg}} \leq 252.5 \text{ kHz}$$

At least 99.9% of all $\Delta f_{2_{max}}$ frequency values recorded over 10 LE test packets are greater than 185 kHz.

$$\frac{\Delta f_{2_{avg}}}{\Delta f_{1_{avg}}} \geq 0.8$$

4.4.7 RF-PHY/TRM/BV-10-C [Modulation Characteristics at 2 Ms/s]

- Test Purpose

This test verifies that the modulation characteristics of the transmitted signal are correct when the transmitter is operating at 2 Ms/s.

- Reference

[6] Chapter 3.1.1

- Initial Condition

As for RF-PHY/TRM/BV-05-C (Modulation Characteristics, uncoded data at 1 Ms/s), but transmitter is operating at 2 Ms/s symbol rate. The value of MAX_TX_LENGTH_2M (for which the TC is performed) is specified in Section 6.7.



- Test Procedure

As for RF-PHY/TRM/BV-05-C (Modulation Characteristics, uncoded data at 1 Ms/s), but transmitter is operating at 2 Ms/s symbol rate.

In all steps the value MAX_TX_LENGTH_2M shall be used instead of MAX_TX_LENGTH.

In Step 3) the demodulator filter BW shall be set to a minimum of 4MHz. The demodulator filter passband ripple shall be 0.5 dB peak-to-peak max. within ± 1.1 MHz. The following measurement channel filter minimum attenuator characteristics shall be used:

± 1.3 MHz	-3 dB
± 2.0 MHz	-14 dB
± 4.0 MHz	-44 dB

- Test Condition

Common Test Case Conditions defined in Section 4.2 apply.

- Expected Outcome

Pass Verdict

All measured values must fulfill the following conditions at the low, medium and high frequencies:

$$450 \text{ kHz} \leq \Delta f_{1_{avg}} \leq 550 \text{ kHz}$$

At least 99.9 percent of all $\Delta f_{2_{max}}$ frequency values recorded over 10 LE test packets must be greater than 370 kHz.

$$\frac{\Delta f_{2_{avg}}}{\Delta f_{1_{avg}}} \geq 0.8$$

4.4.8 RF-PHY/TRM/BV-11-C [Stable Modulation Characteristics at 2 Ms/s]

- Test Purpose

This test verifies the modulation characteristics are within limits for Stable Modulation Index when the transmitter is operating at 2 Ms/s.

- Reference

[6] Chapter 3.1.1

- Initial Condition

As for RF-PHY/TRM/BV-05-C (Modulation Characteristics, uncoded at 1 Ms/s), but transmitter is operating at 2 Ms/s symbol rate. The value of MAX_TX_LENGTH_2M (for which the TC is performed) is specified in Section 6.7.



- Test Procedure

As for RF-PHY/TRM/BV-05-C (Modulation Characteristics, uncoded at 1 Ms/s) but transmitter is operating at 2 Ms/s symbol rate.

In all steps the value MAX_TX_LENGTH_2M shall be used instead of MAX_TX_LENGTH.

- Test Condition

Common Test Case Conditions defined in Section 4.2 apply.

- Expected Outcome

Pass Verdict

All measured values fulfill the following conditions at the low, medium and high frequencies:

$$495 \text{ kHz} \leq \Delta f_{1_{avg}} \leq 505 \text{ kHz}$$

At least 99.9 percent of all $\Delta f_{2_{max}}$ frequency values recorded over 10 LE test packets are greater than 370 kHz.

$$\frac{\Delta f_{2_{avg}}}{\Delta f_{1_{avg}}} \geq 0.8$$

4.4.9 RF-PHY/TRM/BV-12-C [Carrier frequency offset and drift at 2 Ms/s]

- Test Purpose

This test verifies that the carrier frequency offset and carrier drift of the transmitted signal at 2 Ms/s is within specified limits at normal operating conditions.

- Reference

[6] Chapter 3.3

- Initial Condition

As for RF-PHY/TRM/BV-06-C (Carrier frequency offset and drift, uncoded data at 1 Ms/s). The value of MAX_TX_LENGTH_2M (for which the TC is performed) is specified in Section 6.7.

- Test Procedure

As for RF-PHY/TRM/BV-06-C (Carrier frequency offset and drift, uncoded data at 1 Ms/s), but with the following differences:

In all steps the transmitter is set to operate at 2 Ms/s symbol rate.

In all steps the value MAX_TX_LENGTH_2M shall be used instead of MAX_TX_LENGTH.

In Step 3) the demodulator filter passband ripple shall be 0.5 dB peak-to-peak max. within ± 1.1 MHz.

In Step 3) the recommended measurement channel filter minimum attenuator characteristics should be as follows:

±1.3 MHz	-3 dB
±2.0 MHz	-14 dB
±4.0 MHz	-44 dB

In Step 4) the tester is to integrate the frequency of the FM demodulated signal from the center of the first preamble bit to the center of the first bit following the 16th preamble bit, 16 bits in total.

In Step 6) the tester should integrate the frequency of the FM demodulated signal in 20-bit intervals.

- Test Condition

Common Test Case Conditions defined in Section 4.2 apply.

- Expected Outcome

As for RF-PHY/TRM/BV-06-C (Carrier frequency offset and drift, uncoded data at 1 Ms/s) except that the maximum drift rate applies to the difference between any two 20-bit groups separated by 50µs within the payload field of the packet transmitted by the IUT.

4.4.10 RF-PHY/TRM/BV-13-C [Modulation Characteristics, LE Coded (S=8)]

- Test Purpose

This test verifies that the modulation characteristics of the transmitted signal are correct for an LE Coded signal (S=8). The IUT is placed in direct test mode with the PHY set to LE Coded (S=8). Test packets are generated and the encoding is confirmed for correctness.

- Reference

[6] Chapter 3.1

- Initial Condition

- The IUT is set to direct TX mode at maximum output power. Whitening shall be turned off.
- Frequency hopping off, fixed frequency
- The value of MAX_TX_LENGTH_CODED_S8 (for which the TC is performed) is specified in Section 6.7.

- Test Procedure

1. The IUT is set to transmit at the lowest frequency for testing as defined in Section 6.2.
2. The IUT transmits LE test packets with MAX_TX_LENGTH_CODED_S8 octet packet payload consisting of a repetitive sequence of 0xFF octets (binary '11111111' in transmission order). See [4], Section 4, "LE Test Packet Definition", for details. This sequence, once passed through the S=8 encoder, becomes a repetitive sequence of '00111100' symbols. The symbol duration is 1µs.



3. The followings settings shall be used for the tester:

Center frequency	lowest frequency for testing as defined in Section 6.2
Mode	FM demodulation
Demodulator filter BW	2 MHz (minimum)
Filter passband ripple	0.5 dB peak-to-peak max. within ± 550 kHz
Trigger	RF (trigger on rising edge)

Recommended measurement channel filter minimum attenuator characteristics;

± 650 kHz	-3 dB
± 1 MHz	-14 dB
± 2 MHz	-44 dB

4. The payload is FM demodulated with the settings described in Step 3). The measurement shall start at the beginning of the 31st symbol in the payload. The last 34 symbols in the payload shall be disregarded.
5. Each individual symbol is to be oversampled at least 32 times. The sequence center frequency f_{1ccf} is calculated as the average frequency of all samples over each '00001111' sequence.
6. For the second, third, sixth and seventh symbols in each '00001111' sequence, the absolute value of the frequency offset from f_{1ccf} is recorded as Δf_{1max} . Δf_{1max} is defined as the average deviation for each individual symbol. See Figure 4.1 for reference.
7. The average frequency value of all Δf_{1max} frequencies in a packet is calculated and recorded as Δf_{1avg} .
8. Steps 2–7 are repeated for a minimum of 10 packets.
9. Steps 2–8 are repeated when the IUT is transmitting at the remaining frequencies defined in Section 6.2.

- Test Condition

Common Test Case Conditions defined in Section 4.2 apply.

- Expected Outcome

Pass Verdict

All measured values fulfill the following conditions at the low, medium, and high frequencies:

$$225 \text{ kHz} \leq \Delta f_{1avg} \leq 275 \text{ kHz}$$

At least 99.9 percent of all Δf_{1max} frequency values recorded over 10 LE test packets are greater than 185 kHz.

- Notes

To compensate for the statistical distribution of individual samples, the decision criteria is applied to 99.9 percent of the sample values.



4.4.11 RF-PHY/TRM/BV-14-C [Carrier frequency offset and drift, LE Coded (S=8)]

- Test Purpose

This test verifies that the carrier frequency offset and carrier drift of the transmitted signal is within specified limits at normal operating conditions for LE Coded PHY with S=8.

- Reference

[2] Chapter 3.3

- Initial Condition

The IUT is set to direct TX mode at maximum output power. Whitening shall be turned off.

Frequency hopping off, fixed frequency

The value of MAX_TX_LENGTH_CODED_S8 (for which the TC is performed) is specified in Section 6.7.

- Test Procedure

1. The IUT is set to transmit at the lowest frequency for testing as defined in Section 6.2.
2. The IUT transmits LE test packets with MAX_TX_LENGTH_CODED_S8 octet payload consisting of a repetitive sequence of 0xFF octets (binary '11111111' in transmission order) in the payload. See [4], Section 4, "LE Test Packet Definition" for details. This sequence, once passed through the S=8 encoder, becomes a repetitive sequence of '00111100' symbols. The symbol duration is 1 μ s.
3. The followings settings shall be used for the tester:

Center frequency	lowest frequency for testing as defined in Section 6.2
Mode	FM demodulation
Demodulator filter BW	2 MHz (minimum)
Filter passband ripple	0.5dB peak-to-peak max. within \pm 550 kHz
Trigger	RF (trigger on rising edge)

Recommended measurement channel filter minimum attenuator characteristics;

\pm 650 kHz	-3 dB
\pm 1 MHz	-14 dB
\pm 2 MHz	-44 dB

4. The packet is FM demodulated with the settings described in step 3. The measurement shall start at the beginning of the 3rd symbol of the preamble field in the transmitted packet. The tester integrates the frequency of the FM demodulated signal in groups of 16 symbols. The first symbol in the integration group corresponds to the third symbol of the preamble (first 1 of the '11110000'... sequence). The last 14 symbols of the preamble shall be disregarded.
5. The integral sums of the four integration periods are recorded as f0, f1, f2, and f3.



6. Throughout the payload of the packet, the tester integrates the frequency of the FM demodulated signals in 16-symbol intervals, starting at the 27th symbol in the PDU payload and until the $(8 * \text{MAX_TX_LENGTH_CODED_S8})$ th symbol. The last 16-symbol sequence should not overlap the CRC-field at the end of the packet. See Figure 4.6 for reference. The integral sums are recorded as f_n , when n is an integer from 5 to k . f_k represents the last integral sum before the start of the CRC field in the packet.
7. Steps 2–7 are repeated for a minimum of 10 packets.
8. Steps 2–7 are repeated when the IUT is transmitting at the remaining frequencies defined in Section 6.2.

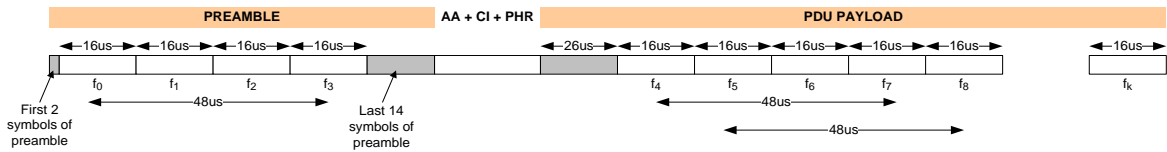


Figure 4.6: Frequency drift rate measurement principle for $S=8$

- Test Condition

Common Test Case Conditions defined in Section 4.2 apply.

- Expected Outcome

The maximum drift rate is 19.2 kHz/48 μ s, anywhere in the packet. The maximum drift rate applies to the difference between any two groups of 16 symbols separated by 48 μ s within the payload field of the packet transmitted by the IUT. The requirement also applies to the frequency difference between the initial frequency measurement f_0 and f_3 within the preamble. See Figure 4.6 for reference.

All measured values fulfill the following conditions at the low, medium and high frequencies.

Pass Verdict

$$f_{TX} - 150 \text{ kHz} \leq f_n \leq f_{TX} + 150 \text{ kHz}$$

where f_{TX} is the nominal transmit frequency and $n=0,1,2,3\dots k$

$$|f_0 - f_n| \leq 50 \text{ kHz}$$

where $n= 1,2,3\dots k$

$$|f_0 - f_3| \leq 19.2 \text{ kHz and}$$

$$|f_n - f_{(n-3)}| \leq 19.2 \text{ kHz}$$

where $n= 7,8,9\dots k$

In all of the above pass verdict requirements, f_k is the last frequency measurement before the CRC field.

4.4.12 RF-PHY/TRM/BV-15-C [Output power, With Constant Tone Extension]

This test verifies the maximum peak and average power emitted from the IUT when transmitting with a Constant Tone Extension.

- Reference
 - [8] Chapter 3
- Initial Condition
 - The IUT is set to direct TX mode at maximum output power. Whitening shall be turned off.
 - Frequency hopping off, fixed frequency
 - The values of MAX_TX_LENGTH and TSPX_CTE_len_max (for which the TC is performed) are specified in Section 6.7.
 - The IUT is set to transmit AoA Constant Tone Extensions.

- Test Procedure

1. The IUT transmits LE test packets with PRBS9 payload (MAX_TX_LENGTH octets) and with TSPX_CTE_len_max * 8 μ s Constant Tone Extension. See [9], Section 4, “LE Test Packet Definition” for details.
2. The followings settings shall be used for the tester:

Center frequency	at the lowest frequency for testing as defined in Section 6.2
Frequency span	Zero span
Resolution BW	3 MHz
Video BW	3 MHz
Detector	Peak
Mode	Clear/Write
Sweep time	Must cover at least one complete test packet
Trigger	RF (trigger on rising edge)

3. Upon packet transmission, the tester is triggered to make a sweep over the duration of one packet. The sweep shall start at the beginning of the first bit in the preamble.
4. The peak power value, PPK, of the sweep is recorded.
5. The tester calculates average power PAVG over at least 20% to 80% of the duration of the burst (position of p0 defines the beginning of the burst; see Section 6.5 Definition of the Position of Bit p0).
6. Steps 2–5 are repeated for the remaining frequencies defined in Section 6.2.

- Test Condition

Common Test Case Conditions defined in Section 4.2 apply.



- Expected Outcome

Pass Verdict

All measured values fulfill the following conditions:

1. $-20 \text{ dBm} \leq \text{PAVG} \leq +20 \text{ dBm}$
2. $\text{PPK} \leq (\text{PAVG} + 3 \text{ dB})$

4.4.13 RF-PHY/TRM/BV-16-C [Carrier frequency offset and drift, uncoded data at 1 Ms/s, Constant Tone Extension]

This test verifies that the carrier frequency offset and carrier drift of the transmitted Constant Tone Extension portion in a transmitted signal with uncoded data at 1 Ms/s with a Constant Tone Extension is within specified limits at normal operating conditions.

- Reference

[8] Chapter 3.3

- Initial Condition

- The IUT is set to direct TX mode at maximum output power. Whitening shall be turned off.
- Frequency hopping off, fixed frequency
- The values of MAX_TX_LENGTH and TSPX_CTE_len_max (for which the TC is performed) are specified in Section 6.7.
- The IUT is set to transmit AoA Constant Tone Extensions.

- Test Procedure

1. The IUT is set to transmit at the lowest frequency for testing as defined in Section 6.2.
2. The IUT transmits LE test packets with MAX_TX_LENGTH octet payload consisting of a repetitive sequence of 0Fhex octets (11110000bin in transmission order) in the payload and with TSPX_CTE_len_max * 8 μs Constant Tone Extension. See [9] Section 4, “LE Test Packet Definition” for details.
3. The followings settings shall be used for the tester:

Center frequency	lowest frequency for testing as defined in Section 6.2
Mode	FM demodulation
Demodulator filter BW	2 MHz (minimum)
Filter passband ripple	0.5 dB peak-to-peak max. within ±550 kHz
Trigger	RF (trigger on rising edge)

Recommended measurement channel filter minimum attenuator characteristics;

± 650kHz	-3 dB
± 1 MHz	-14 dB
± 2 MHz	-44 dB



4. The payload is FM demodulated with the settings described in 3. The average frequency deviation measurement shall start at the beginning of the fifth bit of the payload (See [Figure 4.7](#) for description). The last four bits in the payload shall be disregarded (i.e. last bit in the measurement is the fourth bit in the MAX_TX_LENGTHth octet).
5. Each individual bit is to be oversampled at least 32 times. The sequence center frequency; f_{1ccf} is calculated as the average frequency of all samples over each 00001111bin sequence.
6. For the second, third, sixth and seventh bits in each 00001111bin sequence, the absolute value of the frequency offset from f_{1ccf} is recorded as Δf_{1max} . Δf_{1max} is defined as the average deviation for each individual bit. See [Figure 4.7](#) for reference.
7. The average frequency value of all Δf_{1max} frequencies in a packet is calculated and recorded as Δf_{1avg} .
8. The initial frequency offset measurement f_0 is to be performed at the start of the preamble field in the transmitted packet. The tester integrates the frequency of the FM demodulated signal from the center of the first preamble bit to the center of the first bit following the 8th preamble bit, 8 bits in total. See [Figure 4.8](#) for reference.
9. The integral sum in 4 is considered to be the initial carrier frequency of the IUT, and is recorded as f_0 .
10. The average center frequency measurement f_p is to be performed starting at the $(n+1)$ th bit of the payload and covering 16 bits, where $n = (\text{MAX_TX_LENGTH} * 8) - 20$. The first n bits and the last 4 bits shall not be used for this measurement. See [Figure 4.9](#) and [Figure 4.10](#) for reference.
11. The average frequency deviation measurement f_{3maxi} and carrier frequency offset measurement f_{si} within the Constant Tone Extension are to be performed starting at the first bit of the reference period within the Constant Tone Extension covering 16 μs units. The first 4 μs of the Constant Tone Extension shall not be used for the measurement. For bursts with odd number of Constant Tone Extension units, the last 4 μs of the Constant Tone Extension portion shall not be used. For bursts with even number of Constant Tone Extension units, the last 12 μs of the Constant Tone Extension portion shall not be used for the measurement. f_{si} shall be recorded as $f_{3maxi} - \Delta f_{1avg}$. See [Figure 4.11](#) for reference.
12. Steps 2–11 are repeated for a minimum of 10 packets.
13. Steps 2–12 are repeated when the IUT is transmitting at the remaining frequencies defined in [Section 6.2](#).

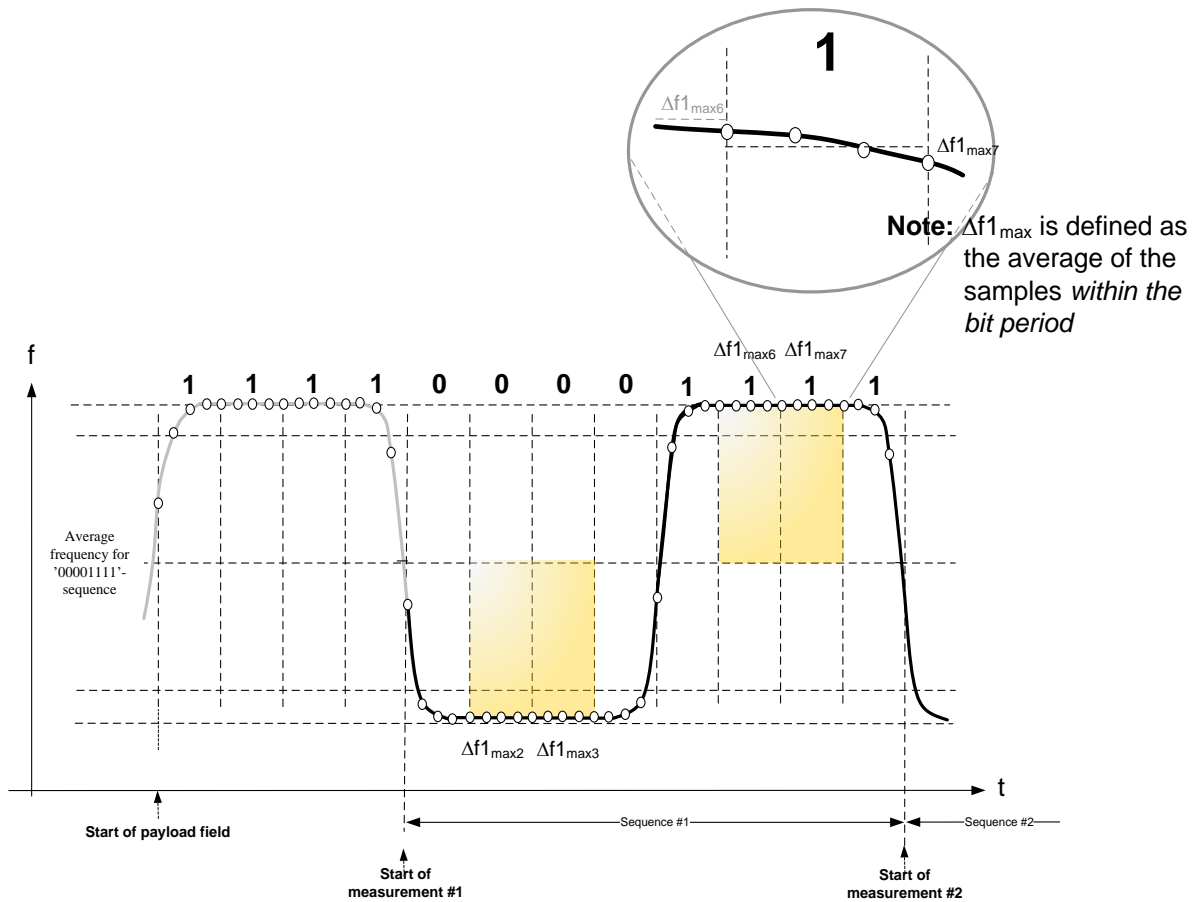


Figure 4.7: Frequency deviation measurement principle for 11110000-payload sequence

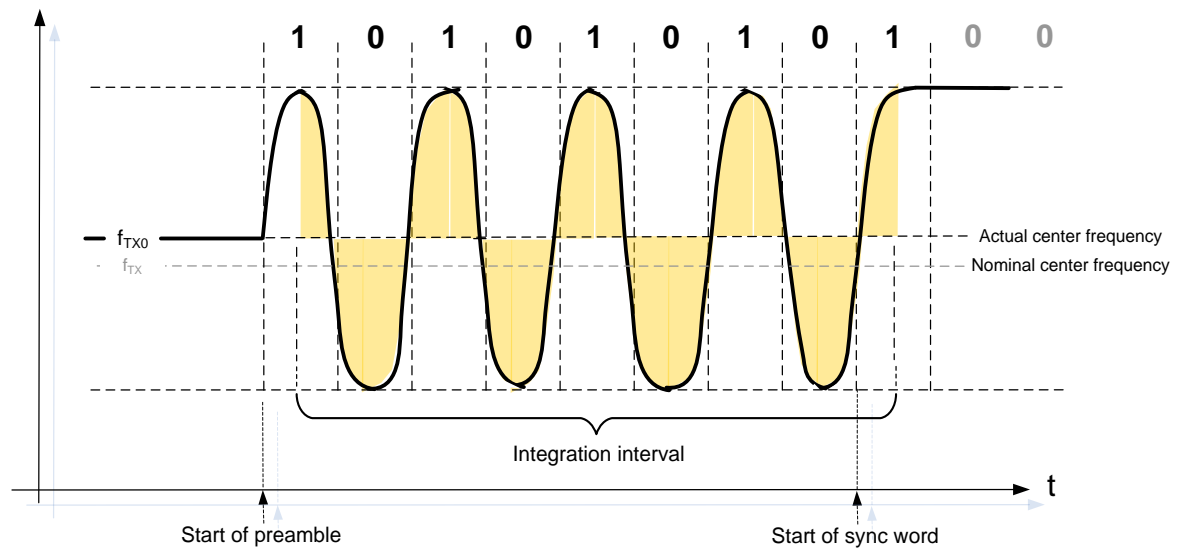


Figure 4.8: Initial carrier frequency (f_0) measurement principle

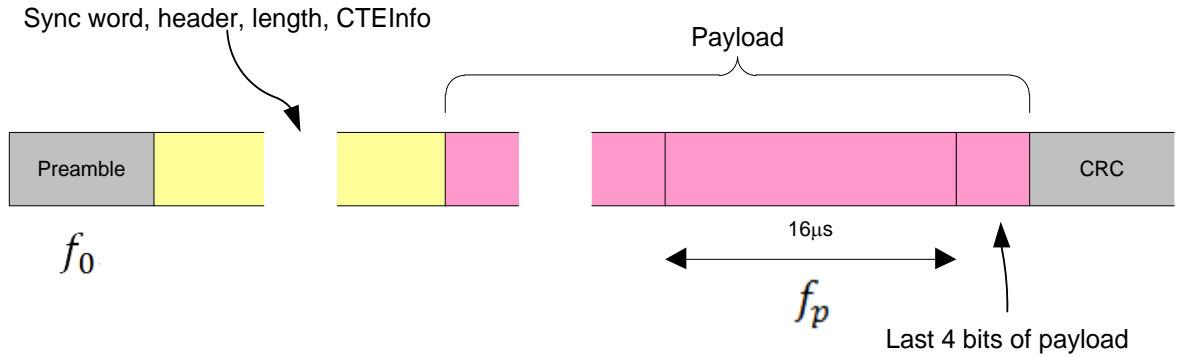


Figure 4.9: Average center frequency measurement (f_p) measurement location

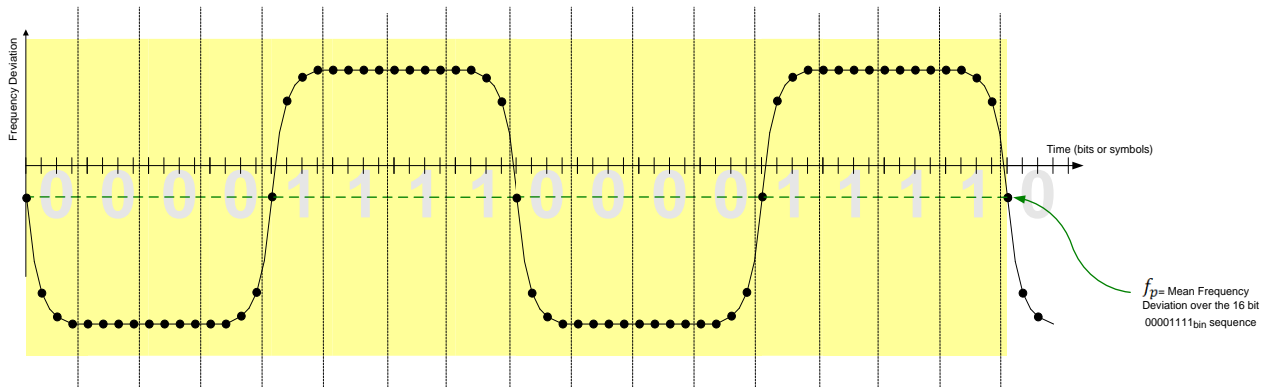


Figure 4.10: Average center frequency measurement (f_p) principle

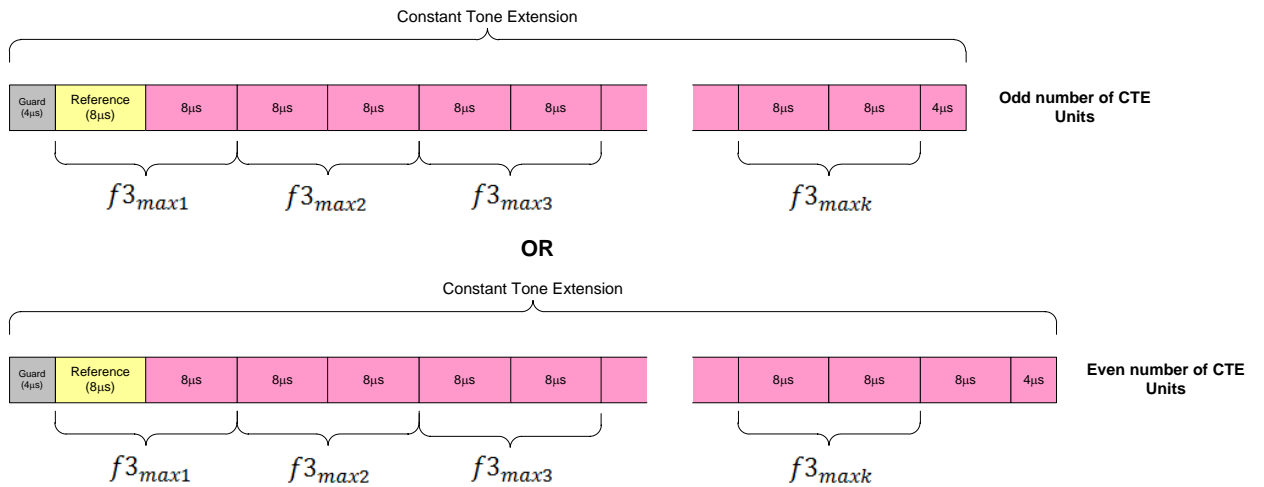


Figure 4.11: Average frequency deviation measurement principle

- Test Condition
Common Test Case Conditions defined in Section 4.2 apply.

- Expected Outcome

Pass Verdict

$$f_{TX} - 150 \text{ kHz} \leq f_{si} \leq f_{TX} + 150 \text{ kHz}$$

where f_{TX} is the nominal transmit frequency and $n=0,1,2,3\dots l$

$$|f_{s1} - f_p| \leq 19.2 \text{ kHz}$$

$$|f_{si} - f_0| \leq 50 \text{ kHz}$$

where $i=1,2,3,4\dots k$

$$|f_{si} - f_{si-3}| \leq 19.2 \text{ kHz}$$

where $i=4\dots k$

4.4.14 RF-PHY/TRM/BV-17-C [Carrier frequency offset and drift at 2 Ms/s, Constant Tone Extension]

This test verifies that the carrier frequency offset and carrier drift of the transmitted Constant Tone Extension portion in a transmitted signal at 2 Ms/s with a Constant Tone Extension is within specified limits at normal operating conditions.

- Reference

[8] Chapter 3.3

- Initial Condition

As for RF-PHY/TRM/BV-16-C (Carrier frequency offset and drift, uncoded data at 1 Ms/s, Constant Tone Extension). The values of MAX_TX_LENGTH_2M and TSPX_CTE_len_max (for which the TC is performed) are specified in Section 6.7.

- Test Procedure

As for RF-PHY/TRM/BV-16-C (Carrier frequency offset and drift, uncoded data at 1 Ms/s, Constant Tone Extension), but with the following differences:

In all steps the transmitter is set to operate at 2 Ms/s symbol rate.

In all steps the value MAX_TX_LENGTH_2M shall be used instead of MAX_TX_LENGTH.

In Step 3 the demodulator filter passband ripple shall be 0.5 dB peak-to-peak max. within ± 1.1 MHz.

In Step 3 the recommended measurement channel filter minimum attenuator characteristics should be as follows:

± 1.3 MHz	-3 dB
± 2.0 MHz	-14 dB
± 4.0 MHz	-44 dB



In Step 8 the tester is to integrate the frequency of the FM demodulated signal from the center of the first preamble bit to the center of the first bit following the 16th preamble bit, 16 bits in total.

In Step 10 the average center frequency measurement f_p is to be performed starting at the $(n+1)$ th bit of the payload and covering 32 bits, where $n = (\text{MAX_TX_LENGTH_2M} * 8) - 36$. The first n bits and the last 4 bits shall not be used for this measurement.

- Test Condition

Common Test Case Conditions defined in Section 4.2 apply.

- Expected Outcome

As for RF-PHY/TRM/BV-16-C (Carrier frequency offset and drift, uncoded data at 1 Ms/s, Constant Tone Extension), except

$$|f_{s1} - f_p| \leq 13.6 \text{ kHz}$$

4.4.15 Tx Power Stability, AoD Transmitter

- Test Purpose

This test verifies that the AoD transmit signal has settled at the beginning of the reference period and the transmit slots, and remains stable within the reference period and transmit slots, respectively.

- Reference

[8] Section 5

[9] Section 4.1

- Initial Condition

- The IUT is set to direct TX mode at maximum output power. Whitening shall be turned off.
- Frequency hopping off, fixed frequency
- The values of TSPX_CTE_len_max (for which the TC is performed) are specified in Section 6.7.
- IUT is set for a symbol rate as specified in Table 4.2.

- Test Procedure

1. The IUT transmits LE test packets with no payload and with TSPX_CTE_len_max * 8 μ s Constant Tone Extension with switching slots as specified in Table 4.2. See [9], Section 4, "LE Test Packet Definition" for details.
2. The followings settings shall be used for the tester:
 - Center Frequency at the lowest frequency for testing as defined in Section 6.2
 - Frequency Span Zero Span
 - Resolution BW 3MHz
 - Video BW 3MHz
 - Detector Average
3. The RF power of the CTE is measured with the settings described in 2.



4. The tester records $P_{REF,AVE}$, as the average power during the reference period, measured from the beginning of the first symbol of the reference period to the end of the last symbol within the reference period.
5. The tester records $P_{REF,DEV}$ as the maximum absolute deviation between any one sample of the output power taken during the reference period relative to $P_{REF,AVE}$, recorded in step 4.
6. For each transmit slot, n , tester records $P_{n,AVE}$ as the average power within the slot, where n is an integer from 1 to k , where k is the number of transmit slots within the packet.
7. For each transmit slot, n , tester records $P_{n,DEV}$ as the as the maximum absolute deviation between any one sample of the output power within the transmit slot relative to average power within the slot, $P_{n,AVE}$, recorded in step 6.
8. Steps 3 to 7 are repeated when the IUT is transmitting at the remaining frequencies defined in Section 6.2.

- Test Condition

The IUT and Lower Tester are set up according to the cabled testing setup described in Section 4.6 and common Test Case Conditions defined in Section 4.2 apply.

- Expected Outcome

The maximum deviation of the signal power within the reference period, shall not be more than 25% of the average signal power measured within the reference period.

The maximum deviation of the signal power within a TX slot shall not be more than 25% of the average signal power measured within that TX slot.

All measured values fulfill the following conditions at the low, medium and high frequencies.

Pass Verdict

For each frequency, the following conditions are satisfied:

- $P_{REF,DEV} / P_{REF,AVE} < 0.25$
- $P_{n,DEV} / P_{n,AVE} < 0.25$ for $n=1,2,3,\dots,k$

Test Case	PHY	Slot Duration
4.4.15.1 RF-PHY/TRM/PS/BV-01-C [Tx Power Stability, AoD Transmitter at 1 Ms/s with 2 μs Switching Slot]	1 Ms/s	2 μ s
4.4.15.2 RF-PHY/TRM/PS/BV-02-C [Tx Power Stability, AoD Transmitter at 1 Ms/s with 1 μs Switching Slot]	1 Ms/s	1 μ s
4.4.15.3 RF-PHY/TRM/PS/BV-03-C [Tx Power Stability, AoD Transmitter at 2 Ms/s with 2 μs Switching Slot]	2 Ms/s	2 μ s
4.4.15.4 RF-PHY/TRM/PS/BV-04-C [Tx Power Stability, AoD Transmitter at 2 Ms/s with 1 μs Switching Slot]	2 Ms/s	1 μ s

Table 4.2: Tx Power Stability, AoD Transmitter Test Cases



4.4.16 Antenna switching integrity, AoD Transmitter

- Test Purpose

This test verifies that the antenna switching occurs during the switching slots of the Constant Tone Extension for an AoD transmit signal.

- Reference

[8] Section 5

[9] Section 4.1

- Initial Condition

- The IUT is set to direct TX mode at maximum output power. Whitening shall be turned off.
- Frequency hopping off, fixed frequency
- The values of TSPX_CTE_len_max (for which the TC is performed) are specified in Section 6.7.
- IUT is set for a symbol rate as specified in [Table 4.3](#).

- Test Procedure

1. The IUT transmits LE test packets with no payload and with TSPX_CTE_len_max * 8 μ s Constant Tone Extension with switching slots as specified in [Table 4.3](#). See [9], Section 4, “LE Test Packet Definition” for details.
2. The followings settings shall be used for the tester:
 - Center Frequency at the lowest frequency for testing as defined in Section 6.2
 - Frequency Span Zero Span
 - Resolution BW 3MHz
 - Video BW 3MHz
 - Detector Average
3. All non-reference antenna ports are disconnected and terminated.
4. Tester records the average output power during nth Tx slot, where n = 1 to k (Nof Tx slots in the packet), Pn,AVE,OFF.
5. Connect the Xth non reference antenna port, where X = 1 .. number of non-reference antennas. All other non-reference antennas are disconnected and terminated.
6. Tester records the average output power during the nth Tx slot, where n = 1 to k (Nof Tx slots in the packet), Pn,X,AVE,ON.
7. Repeat steps 5–6 for all non-reference antennas.

- Test Condition

The IUT and Lower Tester are set up according to the cabled testing setup described in [Section 4.6](#) and common Test Case Conditions defined in [Section 4.2](#) apply.

- Expected Outcome

The average signal power measured when an antenna port is connected shall be at least 10 dB greater than the average signal power measured when the antenna port is disconnected in the transmit slots corresponding to the antenna.



All measured values fulfill the following conditions at the low, medium and high frequencies.

Pass Verdict

For each frequency, the following conditions are satisfied:

- $P_{m,X,AVE,ON} - P_{m,AVE,OFF} \geq 10$ dB,

where m corresponds to the Tx slot corresponding to the antenna X transmission, and

X = 1 .. Number of non-reference antenna

Test Case	PHY	Slot Duration
4.4.16.1 RF-PHY/TRM/ASI/BV-05-C [Antenna switching integrity, AoD Transmitter at 1 Ms/s with 2 μs Switching Slot]	1 Ms/s	2 μ s
4.4.16.2 RF-PHY/TRM/ASI/BV-06-C [Antenna switching integrity, AoD Transmitter at 1 Ms/s with 1 μs Switching Slot]	1 Ms/s	1 μ s
4.4.16.3 RF-PHY/TRM/ASI/BV-07-C [Antenna switching integrity, AoD Transmitter at 2 Ms/s with 2 μs Switching Slot]	2 Ms/s	2 μ s
4.4.16.4 RF-PHY/TRM/ASI/BV-08-C [Antenna switching integrity, AoD Transmitter at 2 Ms/s with 1 μs Switching Slot]	2 Ms/s	1 μ s

Table 4.3: Antenna switching integrity, AoD Transmitter Test Cases

4.5 Receiver Tests (RCV)

4.5.1 RF-PHY/RCV/BV-01-C [Receiver sensitivity, uncoded data at 1 Ms/s]

- Test Purpose

This test verifies that the receiver sensitivity is within limits for non-ideal signals at normal operating conditions when receiving a 1 Ms/s signal. The non-ideal signals used in this test are within the specification limits but deviate from the ideal case.

- Reference

[2] Chapter 4.1

- Initial Condition

- The IUT is set to direct RX mode. Dewhitening shall be turned off.
- Frequency hopping off, fixed frequency
- The tester's transmit power is chosen such that the input power to the IUT receiver is -70 dBm.
- The value of MAX_RX_LENGTH (for which the TC is performed) is specified in Section 6.7.
- The IUT is set to assume the transmitter has a standard modulation index.



- Test Procedure
 1. The IUT is set to receive at the lowest frequency for testing as defined in Section 6.2.
 2. The tester transmits LE test packets with PRBS9 payload (MAX_RX_LENGTH octets). See [4], Section 4, “LE Test Packet Definition” for details.
 3. The signal characteristics of the modulated signal transmitted by the tester are to be changed over time. The signal parameter sets to be used are described in Table 4.4. All other parameters shall be as defined in Section 6.1.
 4. The tester transmits the first 50 packets using the first parameter set; the next 50 packets are transmitted using the second parameter set etc. Upon completion of the last parameter set, the sequence is repeated. The PER is measured according to Section 6.4.
 5. Steps 2–4 are repeated when the IUT is receiving at the remaining frequencies defined in Section 6.2.

Test run	Carrier frequency offset	Modulation index	Symbol timing error
1	100 kHz	0.45	- 50 ppm
2	19 kHz	0.48	- 50 ppm
3	- 3 kHz	0.46	+ 50 ppm
4	1 kHz	0.52	+ 50 ppm
5	52 kHz	0.53	+ 50 ppm
6	0 kHz	0.54	- 50 ppm
7	- 56 kHz	0.47	- 50 ppm
8	97 kHz	0.5	- 50 ppm
9	- 25 kHz	0.45	- 50 ppm
10	- 100 kHz	0.55	+ 50 ppm

Table 4.4: Transmitter parameter settings for PER test

In addition to fixed frequency offset, frequency drift over time is added to the signal characteristics. This is implemented by adding a low frequency modulation to the signal. The modulating signal shall be sinusoidal with deviation of 50 kHz and a modulation frequency of 1250 Hz. The modulating signal shall be synchronized with the packets so that packets start alternately at 0° and 180° of the modulating signal. See Figure 4.12 for reference.

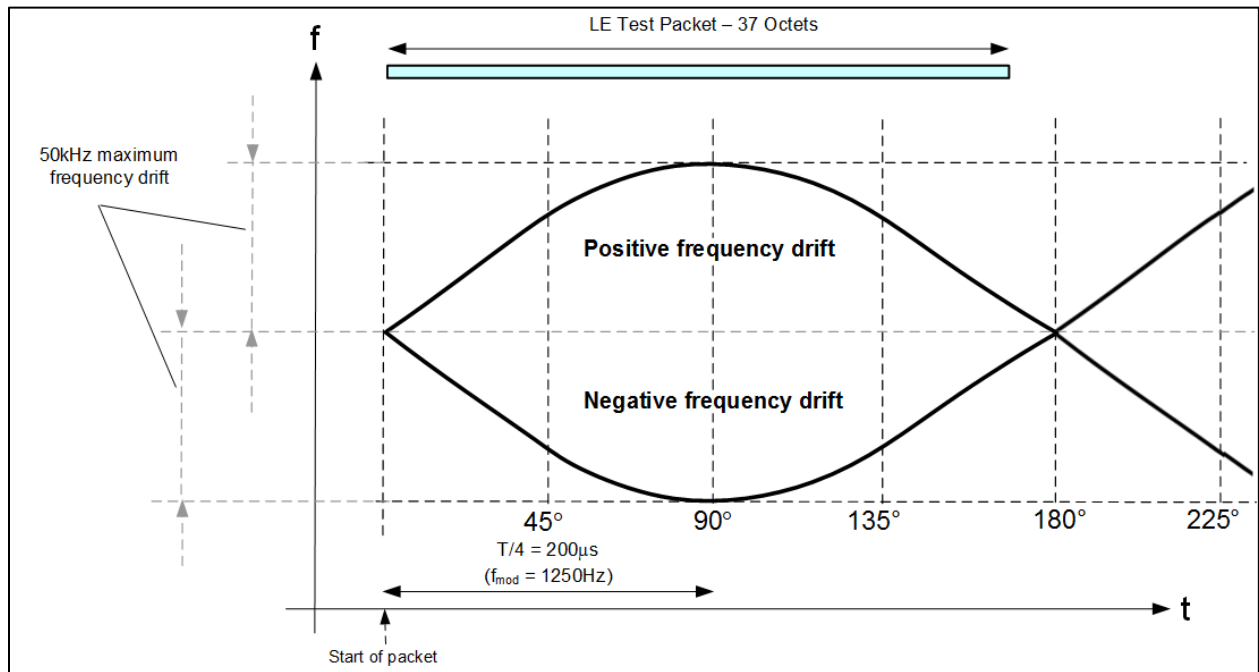


Figure 4.12: Dirty transmitter frequency drift emulation principle

- Test Condition

Common Test Case Conditions defined in Section 4.2 apply.

- Expected Outcome

Pass Verdict

All measured values fulfill the following condition:

PER better than **30.8 percent** for a minimum of **1500** packets transmitted by the tester if the IUT's MAX_RX_LENGTH is 37 bytes.

PER better than the value calculated according to the formula specified in Section 6.4.1 for a minimum of **1500** packets transmitted by the tester if the IUT's MAX_RX_LENGTH is greater than 37 bytes.

4.5.2 RF-PHY/RCV/BV-03-C [C/I and Receiver Selectivity Performance, uncoded data at 1 Ms/s]

- Test Purpose

This test verifies the receiver's performance in presence of co-/adjacent channel interference with uncoded data at 1 Ms/s. The receiver mirror image rejection performance is also verified in this test.

- Reference

[2] Chapter 4.2

- Initial Condition
 - Refer to [Figure 4.13](#) for test setup principle.
 - The IUT is set to direct RX mode. Dewhitening shall be turned off.
 - Frequency hopping off, fixed frequency
 - The image frequency (f_{image}) of the receiver relative to the receiver frequency for a symbol rate of 1 Ms/s is declared by the equipment manufacturer as an IXIT value.
 - The value of MAX_RX_LENGTH (for which the TC is performed) is specified in [Section 6.7](#).
 - IUT is set for a symbol rate of 1 Ms/s.
 - The IUT is set to assume the transmitter has a standard modulation index.
- Test Procedure
 1. The IUT is set to receive at the low operating frequency listed in [Section 6.2](#).
 2. Two test signals are fed to the IUT input port:

Wanted signal:

Packets transmitted at the receiving frequency (f_{RX}) with MAX_RX_LENGTH octet PRBS9 payload at a symbol rate of 1 Ms/s. Refer to [Section 6.1](#) and [\[4\]](#), Section 4 for details. Signal level of the wanted signal at the IUT input port shall be -67dBm.

Interference signal:

Continuous modulated carrier at 2400MHz, modulated with PRBS15 data at a symbol rate of 1 Ms/s. Refer to [Section 6.1](#) and [\[4\]](#), Section 4 for details. Signal level of the interference signal at the IUT input port and frequency relative to the receiving frequency shall be as defined in [Table 4.5](#).
 3. The tester's transmit power is chosen such that the input power to the IUT receiver is as listed in [Table 4.5](#).
 4. Steps 2 to 3 are repeated for interference frequencies 2400MHz+N·MHz where N=1,2,3...83.
 5. The PER is measured according to [Section 6.4](#).
 6. Steps 2 to 5 are repeated when the IUT is receiving at the mid- and high operation frequencies listed in [Section 6.2](#).

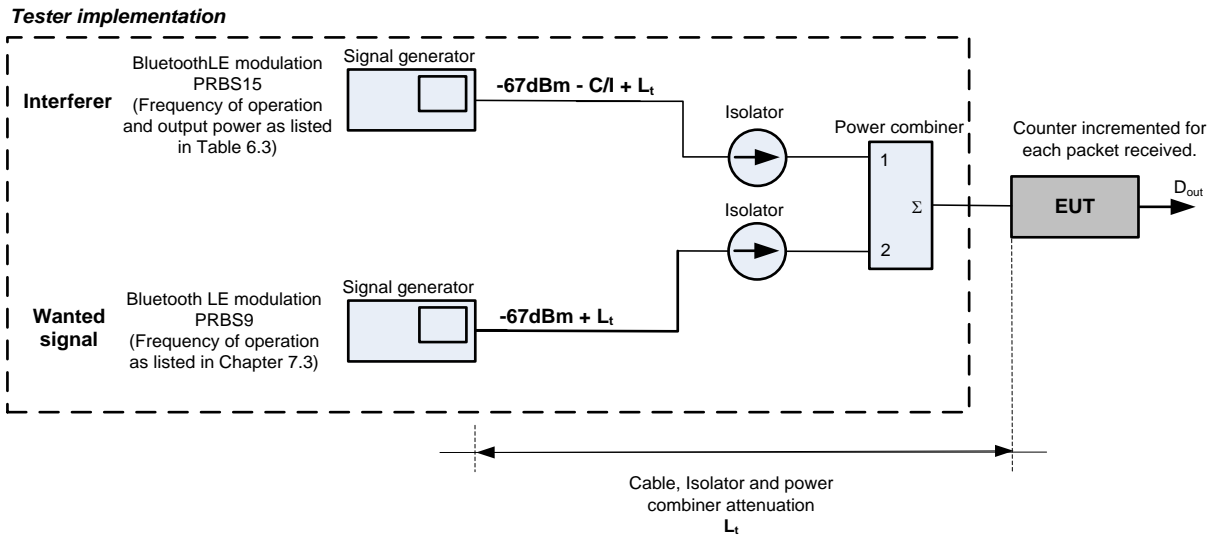


Figure 4.13: C/I- and receiver selectivity test implementation principle

Interference signal frequency1	Interferer signal level at IUT input port	Wanted signal level relative to interference signal level (C/I requirement)
Co-channel (fRX = finterference)	-88 dBm	21 dB
Adjacent channel; finterference = fRX ± 1 MHz	-82 dBm	15 dB
Adjacent channel; finterference = fRX ± 2 MHz	-50 dBm	-17 dB
Adjacent channel; finterference = fRX ± (3+n) MHz [n=0,1,2...]	-40 dBm	-27 dB
Image frequency; finterference = fimage	-58 dBm	-9 dB
Adjacent channel to image frequency; finterference = fimage ± 1 MHz	-52 dBm	-15 dB

Table 4.5: C/I- and receiver selectivity test parameter settings, uncoded data at 1 Ms/s

¹ If two frequencies defined in Table 4.5 refer to the same physical channel, the less stringent requirement applies.

- Test Condition

Common Test Case Conditions defined in Section 4.2 apply.

- Expected Outcome

Pass Verdict

All measured values fulfill the following condition:

PER better than **30.8 percent** for a minimum of **1500** packets transmitted by the tester if the IUT's MAX_RX_LENGTH is 37 bytes.

PER better than the value calculated according to the formula specified in Section 6.4.1 for a minimum of **1500** packets transmitted by the tester if the IUT's MAX_RX_LENGTH is greater than 37 bytes.

For each individual measurement the C/I requirement may be relaxed for a maximum of five interference frequency settings. The C/I-performance shall in this case be equal to, or better than -17 dB (Interference level at least 17 dB higher than wanted signal level). This relaxation applies to the following measurements:

- Adjacent channel; $f_{\text{interference}} = f_{\text{RX}} \pm 2 \text{ MHz}$
- Adjacent channel; $f_{\text{interference}} = f_{\text{RX}} \pm (3+n) \text{ MHz}$ [$n=0,1,2,\dots$]

4.5.3 RF-PHY/RCV/BV-04-C [Blocking Performance, uncoded data at 1 Ms/s]

- Test Purpose

This test verifies that the receiver performs satisfactorily with uncoded data at 1 Ms/s in the presence of interference sources operating outside the 2400MHz – 2483.5MHz band.

- Reference

[2] Chapter 4.3

- Initial Condition

- The IUT is set to direct RX mode. Dewhitening shall be turned off.
- Frequency hopping off, fixed frequency.
- The value of MAX_RX_LENGTH (for which the TC is performed) is specified in Section 6.7.
- IUT is set for a symbol rate of 1 Ms/s.
- The IUT is set to assume the transmitter has a standard modulation index.

- Test Procedure

1. Two test signals are fed to the IUT input port:

Wanted signal:

Modulated carrier, packets transmitted at the mid operating frequency listed in Section 6.2 with MAX_RX_LENGTH octet PRBS9 payload. See Section 6.1 and [4], Section 4 for details. Signal level of the wanted signal at the IUT input port shall be as defined in Table 4.6.



Blocking signal:

Sinusoidal, un-modulated carrier transmitted at a blocker frequency of $f_{\text{blocker}} = 30 \text{ MHz}$. Signal level of the blocker signal at the IUT input port shall be as defined in Table 4.6.

2. The PER is measured according to Section 6.4. If the PER exceeds the minimum requirement, the frequency is recorded as f_{bf_1} .
3. Repeat steps 1) and 2) for $30\text{MHz} \leq f_{\text{blocker}} \leq 12.75\text{GHz}$ with the measurement frequency resolution defined in Table 4.6.
4. $f_{\text{blocker } n+1} = f_{\text{blocker } n} + \text{measurement frequency resolution}$ ($n=0,1,2,\dots$)
5. The PER measurement is repeated for all recorded frequencies in 4) but with -50dBm blocker level at the IUT input ports. If the PER exceeds the minimum requirement, the frequency is recorded as f_{bf_2} .

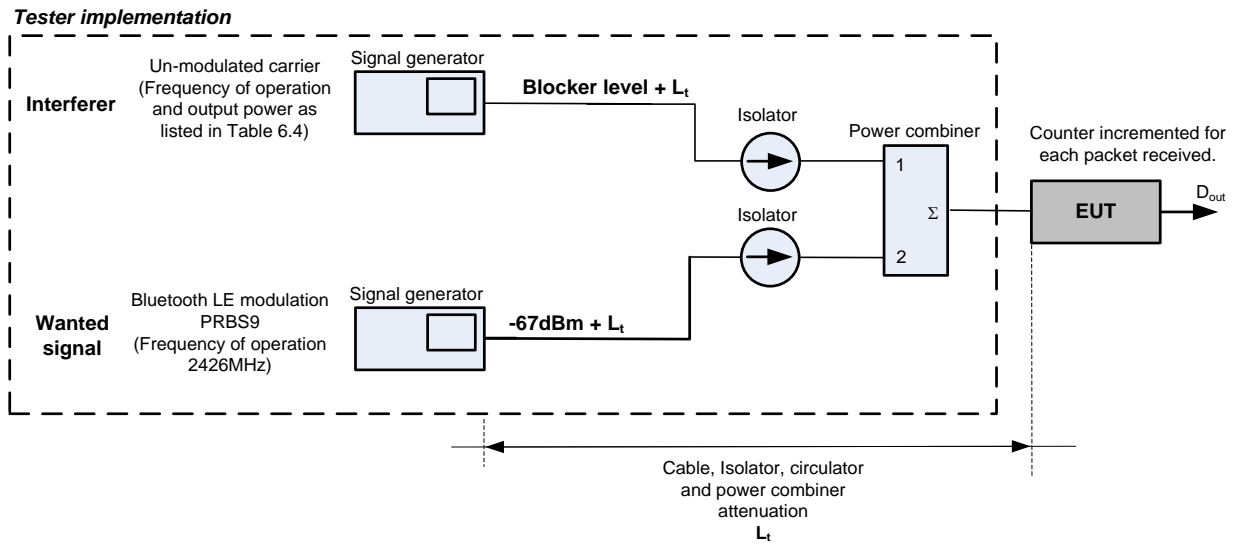


Figure 4.14: Blocking performance test setup principle

Interference signal frequency	Wanted signal level at IUT input port	Blocking signal level at IUT input port	Measurement frequency resolution
30 – 2000 MHz	-67 dBm	-30 dBm	10MHz
2003 – 2399 MHz	-67 dBm	-35 dBm	3MHz
2484 – 2997 MHz	-67 dBm	-35 dBm	3MHz
3000 MHz – 12.75GHz	-67 dBm	-30 dBm	25MHz

Table 4.6: Out-of-band blocking performance and measurement parameters

- Test Condition
Common Test Case Conditions defined in Section 4.2 apply.

- Expected Outcome

Pass Verdict

All measured values fulfill the following condition:

PER better than **30.8 percent** for a minimum of **1500** packets transmitted by the tester if the IUT's MAX_RX_LENGTH is 37 bytes.

PER better than the value calculated according to the formula specified in Section 6.4.1 for a minimum of **1500** packets transmitted by the tester if the IUT's MAX_RX_LENGTH is greater than 37 bytes.

The number of f_{bf_1} frequencies recorded in Step 2 do not exceed 10, and the number of f_{bf_2} frequencies recorded in Step 5 do not exceed 3.

4.5.4 RF-PHY/RCV/BV-05-C [Intermodulation Performance, uncoded data at 1 Ms/s]

- Test Purpose

This test verifies that the receiver intermodulation performance is satisfactory with uncoded data at 1 Ms/s.

- Reference

[2] Chapter 4.4

- Initial Condition

- The IUT is set to direct RX mode. Dewhitening shall be turned off.
- Frequency hopping off, fixed frequency
- The value of MAX_RX_LENGTH (for which the TC is performed) is specified in Section 6.7.
- IUT is set for a symbol rate of 1 Ms/s.
- The IUT is set to assume the transmitter has a standard modulation index.

- Test Procedure

1. The IUT is set to receive at the lowest frequency for testing as defined in Section 6.2. Three test signals are fed to the IUT input port:

Wanted signal:

Modulated carrier, packets transmitted at the receiving frequency (f_{RX}) with MAX_RX_LENGTH octet PRBS9 payload. Refer to Section 6.1 and [4], Section 4 for details. Signal level of the wanted signal at the IUT input port shall be -64 dBm.

Interference signal #1:

Sinusoidal, un-modulated carrier transmitted at an interferer frequency of f_1 . Signal level of the interferer signal at the IUT input port shall be -50dBm.

Interference signal #2:

Continuous modulated carrier at frequency f_2 , modulated with PRBS15 data at a symbol rate of 1 Ms/s. See Section 6.1 and [4], Section 4 for details. Signal level of the interferer signal at the IUT input port shall be -50dBm. The frequency relation between the wanted signal and the interferers shall be as follows;

$$f_{RX} = 2 \cdot f_1 - f_2 \text{ and } |f_2 - f_1| = n \cdot 1 \text{ MHz}$$

where $n=3, 4$ or 5

Once the frequency configuration is chosen, the PER is measured with the interferers both below *and* above the receive frequency, covering both cases implied by $|f_2 - f_1|$, i.e. the PER is measured twice for each receive frequency.

Figure 4.16 shows the frequency combination alternatives for the intermodulation test with uncoded data at 1 Ms/s.

2. The tester's transmit power is chosen such that the input power to the IUT receiver is as listed in 1). Figure 4.15 illustrates the test setup principle.
3. The PER is measured according to Section 6.4.
4. Steps 2) and 3) are repeated when the IUT is receiving at the remaining frequencies defined in Section 6.2.

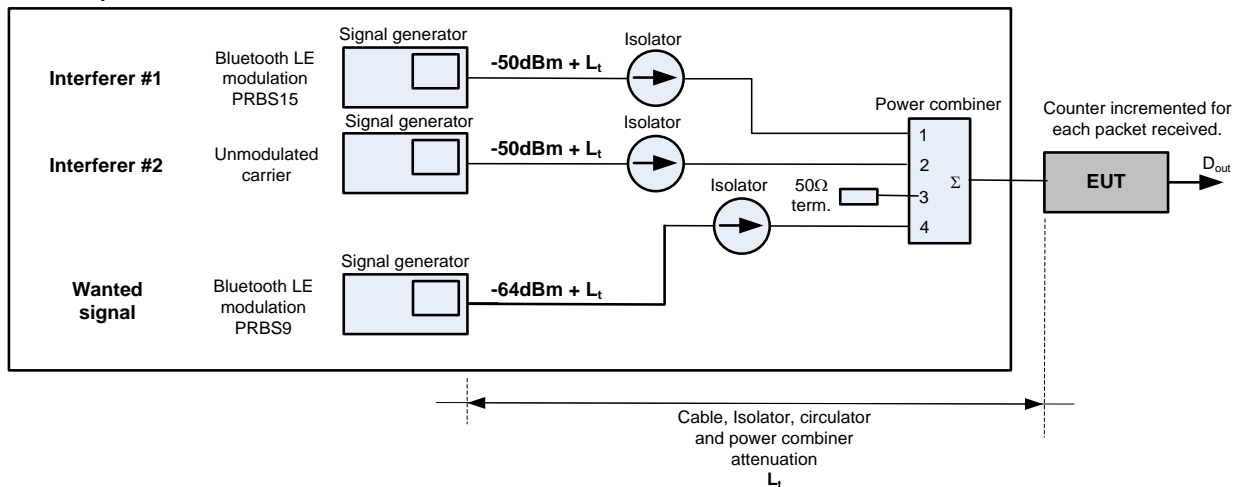
Tester implementation

Figure 4.15: Test setup principle for intermodulation test

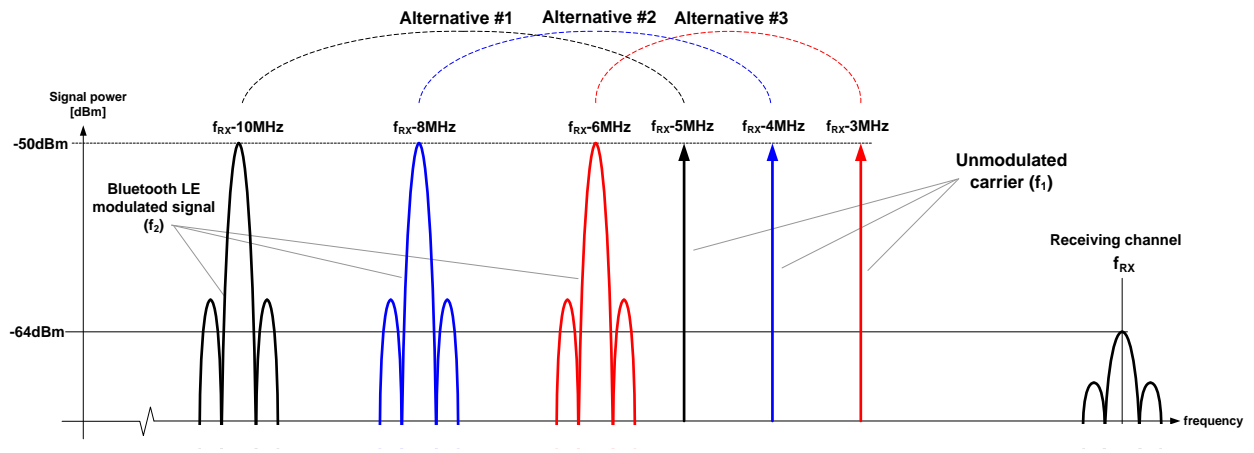


Figure 4.16: Test signal allocation alternatives in the frequency domain at 1 Ms/s. Note: figure shows only frequencies below f_0 .

- Test condition

Common Test Case Conditions defined in Section 4.2 apply.

- Expected outcome

Pass Verdict

The measured values fulfill the following condition:

PER better than **30.8 percent** for a minimum of **1500** packets transmitted by the tester if the IUT's MAX_RX_LENGTH is 37 bytes.

PER better than the value calculated according to the formula specified in Section 6.4.1 for a minimum of **1500** packets transmitted by the tester if the IUT's MAX_RX_LENGTH is greater than 37 bytes.

The value of n (for which the TC is performed) shall be declared by the manufacturer in the IXIT table (See ICS Proforma for Bluetooth low energy RF PHY).

4.5.5 RF-PHY/RCV/BV-06-C [Maximum input signal level, uncoded data at 1 Ms/s]

- Test Purpose

This test verifies that the receiver is able to demodulate a wanted 1 Ms/s signal at high signal input levels.

- Reference

[2] Chapter 4.5

- Initial condition

- The IUT is set to direct RX mode. Dewhitening shall be turned off.
- Frequency hopping off, fixed frequency
- The value of MAX_RX_LENGTH (for which the TC is performed) is specified in Section 6.7.

- IUT is set for a symbol rate of 1 Ms/s.
- The IUT is set to assume the transmitter has a standard modulation index.
- Test procedure
 1. The IUT is set to receive at the lowest frequency for testing as defined in Section 6.2.
 2. The tester transmits packets with MAX_RX_LENGTH octet PRBS9 payload. Refer to Section 6.1, "Reference Signal Definition" and [4], Section 4 for details. The signal level at the IUT input port shall be -10 dBm.
 3. The PER is measured according to Section 6.4.
 4. Steps 1) to 3) are repeated when the IUT is receiving at the remaining frequencies defined in Section 6.2.

- Test condition

Common Test Case Conditions defined in Section 4.2 apply.

- Expected outcome

Pass Verdict

All measured values fulfill the following condition:

PER better than **30.8 percent** for a minimum of **1500** packets transmitted by the tester if the IUT's MAX_RX_LENGTH is 37 bytes.

PER better than the value calculated according to the formula specified in Section 6.4.1 for a minimum of **1500** packets transmitted by the tester if the IUT's MAX_RX_LENGTH is greater than 37 bytes.

4.5.6 RF-PHY/RCV/BV-07-C [PER Report Integrity, uncoded data at 1 Ms/s]

- Test Purpose

This test verifies that the DUT PER report mechanism reports the correct number of received packets to the tester with uncoded data at 1 Ms/s.

- Reference

Section 6.4

[2] Chapter 2.3

- Initial condition

- The IUT is set to direct RX mode. Dewhitening shall be turned off.
- Frequency hopping off, fixed frequency.
- The value of MAX_RX_LENGTH (for which the TC is performed) is specified in Section 6.7.
- The IUT is set to assume the transmitter has a standard modulation index.

- Test Procedure

1. The IUT is set to receive at the middle frequency for testing as defined in Section 6.2.
2. The tester transmits packets with MAX_RX_LENGTH octet PRBS9 payload. Refer to Section 6.1 and [4], Section 4 for details.



3. The total number of packets transmitted by the tester shall be an even random number in the interval $[100 \leq \text{RND} \leq 1500]$.
 4. Every alternating packet transmitted by the tester shall have an intentionally corrupted CRC value.
 5. The signal level at the IUT input port shall be -30 dBm.
 6. The PER is measured according to Section 6.4.
 7. Steps 1–4 are repeated two times (i.e., three PER measurements in total).
- Test Condition
Common Test Case Conditions defined in Section 4.2 apply.

- Expected Outcome

Pass Verdict

All measured values fulfill the following condition:

$50\% \leq \text{PER} \leq (50 + P/2)\%$ for each individual measurement (where P is the appropriate PER value taken from Table 6.4).

4.5.7 RF-PHY/RCV/BV-08-C [Receiver sensitivity at 2 Ms/s]

- Test Purpose

This test verifies that the receiver sensitivity is within limits for non-ideal signals at normal operating conditions when receiving a 2 Ms/s signal. The non-ideal signals used in this test are within the specification limits, but deviate from the ideal case.

- Reference

[6] Chapter 4.1

- Initial Condition

As for RF-PHY/RCV/BV-01-C (Receiver sensitivity, uncoded data at 1 Ms/s), but IUT and transmitter symbol rate is 2 Ms/s. IUT is set to assume the transmitter has a standard modulation index. The value of MAX_RX_LENGTH_2M (for which the TC is performed) is specified in Section 6.7.

- Test Procedure

As for RF-PHY/RCV/BV-01-C (Receiver sensitivity, uncoded data at 1 Ms/s), but the transmitted signal has a symbol rate of 2 Ms/s. In all steps the value MAX_RX_LENGTH_2M shall be used instead of MAX_RX_LENGTH.

- Test Condition

Common Test Case Conditions defined in Section 4.2 apply.

- Expected Outcome

Pass Verdict

All measured values fulfill the following condition:



PER better than **30.8 percent** for a minimum of **1500** packets transmitted by the tester if MAX_RX_LENGTH_2M is 37 bytes.

PER better than the value calculated according to the formula specified in Section 6.4.1 for a minimum of **1500** packets transmitted by the tester if MAX_RX_LENGTH_2M is greater than 37 bytes.

4.5.8 RF-PHY/RCV/BV-09-C [C/I and Receiver Selectivity Performance at 2 Ms/s]

- Test Purpose

This test verifies the receiver's performance in presence of co-/adjacent channel interference at 2 Ms/s. The receiver mirror image rejection performance is also verified in this test.

- Reference

[6] Chapter 4.2

- Initial Condition

Refer to Figure 4.17 for test setup principle.

The IUT is set to direct RX mode. Dewhitening shall be turned off.

Frequency hopping off, fixed frequency

The image frequency ($f_{\text{image-2M}}$) of the receiver relative to the receiver frequency for a symbol rate of 2 Ms/s is declared by the equipment manufacturer as an IXIT value.

The value of MAX_RX_LENGTH_2M (for which the TC is performed) is specified in Section 6.7.

IUT is set for a symbol rate of 2 Ms/s.

IUT is set to assume the transmitter has a standard modulation index.

- Test Procedure

1. The IUT is set to receive at the low operating frequency listed in Section 6.2.
2. Two test signals are fed to the IUT input port:

Wanted signal:

Packets transmitted at the receiving frequency (f_{RX}) with MAX_RX_LENGTH_2M octet PRBS9 payload at a symbol rate of 2 Ms/s. Refer to Section 6.1 and [4], Section 4 for details. Signal level of the wanted signal at the IUT input port shall be -67dBm.

Interference signal:

Continuous modulated carrier at 2400MHz, modulated with PRBS15 data at a symbol rate of 2 Ms/s. Refer to Section 6.1 and [4], Section 4 for details. Signal level of the interference signal at the IUT input port and frequency relative to the receiving frequency shall be as defined in Table 4.7.

3. The tester's transmit power is chosen such that the input power to the IUT receiver is as listed in Table 4.7.



4. Steps 2 to 3 are repeated for interference frequencies $2400\text{MHz} + 2N \cdot \text{MHz}$ where $N=1,2,3\dots 41$.
5. The PER is measured according to Section 6.6.
6. Steps 2 to 5 are repeated when the IUT is receiving at the mid- and high operation frequencies listed in Section 6.2.

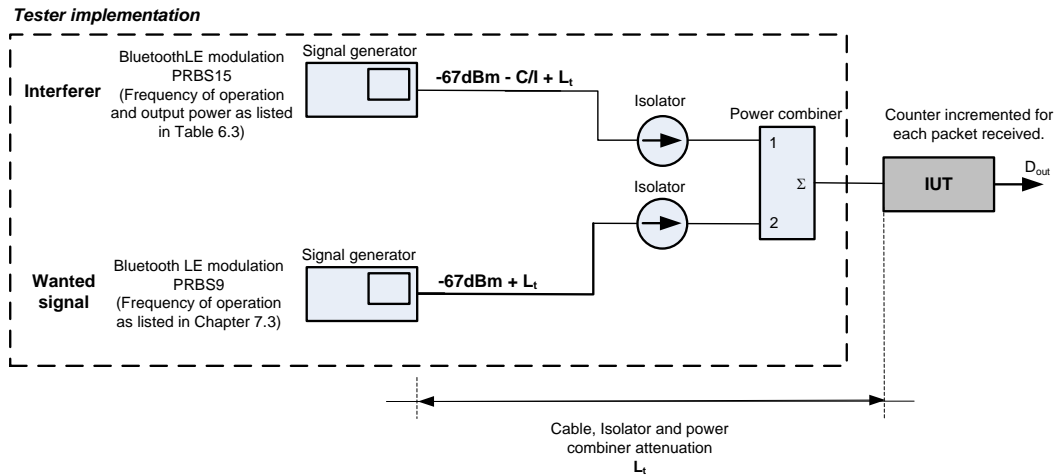


Figure 4.17: C/I- and receiver selectivity test implementation principle

Interference signal frequency ²	Interferer signal level at IUT input port	Wanted signal level relative to interference signal level (C/I requirement)
Co-channel (fRX = finterference)	-88 dBm	21 dB
Adjacent channel; finterference = fRX ± 2 MHz	-82 dBm	15 dB
Adjacent channel; finterference = fRX ± 4 MHz	-50 dBm	-17 dB
Adjacent channel; finterference = fRX ± (6+2n) MHz [n=0,1,2...]	-40 dBm	-27 dB
Image frequency; finterference = fimage-2M	-58 dBm	-9 dB
Adjacent channel to image frequency; finterference = fimage-2M ± 2 MHz	-52 dBm	-15 dB

Table 4.7: C/I- and receiver selectivity test parameter settings at 2 Ms/s

² If two frequencies defined in Table 4.7 refer to the same physical channel, the less stringent requirement applies.

- Test Condition

Common Test Case Conditions defined in Section 4.2 apply.

- Expected Outcome

Pass Verdict

All measured values fulfill the following condition:

PER better than **30.8 percent** for a minimum of **1500** packets transmitted by the tester if MAX_RX_LENGTH_2M is 37 bytes.

PER better than the value calculated according to the formula specified in Section 6.4.1 for a minimum of **1500** packets transmitted by the tester if MAX_RX_LENGTH_2M is greater than 37 bytes.

For each individual measurement the C/I requirement may be relaxed for a maximum of five interference frequency settings. The C/I-performance shall in this case be equal to, or better than -17 dB (Interference level at least 17 dB higher than wanted signal level). This relaxation applies to the following measurements:

- Adjacent channel ± 4 MHz
- Adjacent channel $\pm (6+2n)$ MHz [n=0,1,2...]

4.5.9 RF-PHY/RCV/BV-10-C [Blocking performance at 2 Ms/s]

- Test Purpose

This test verifies that the receiver performs satisfactorily at 2 Ms/s in the presence of interference sources operating outside the 2400MHz – 2483.5MHz band.

- Reference

[6] Chapter 4.3

- Initial Condition

As for RF-PHY/RCV/BV-04-C (Blocking Performance), but IUT is set for a symbol rate of 2 Ms/s. IUT is set to assume the transmitter has a standard modulation index. The value of MAX_RX_LENGTH_2M (for which the TC is performed) is specified in Section 6.7.

- Test Procedure

As for RF-PHY/RCV/BV-04-C (Blocking Performance) but wanted signal has a symbol rate of 2 Ms/s. In all steps the value MAX_RX_LENGTH_2M shall be used instead of MAX_RX_LENGTH.

- Test Condition

Common Test Case Conditions defined in Section 4.2 apply.

- Expected Outcome

Pass Verdict

All measured values fulfill the following condition:

PER better than **30.8 percent** for a minimum of **1500** packets transmitted by the tester if MAX_RX_LENGTH_2M is 37 bytes.

PER better than the value calculated according to the formula specified in Section 6.4.1 for a minimum of **1500** packets transmitted by the tester if MAX_RX_LENGTH_2M is greater than 37 bytes.

The number of f_{bf_1} frequencies recorded in Step 2 do not exceed 10, and the number of f_{bf_2} frequencies recorded in Step 5 do not exceed 3.

4.5.10 RF-PHY/RCV/BV-11-C [Intermodulation performance at 2 Ms/s]

- Test Purpose

This test verifies that the receiver intermodulation performance is satisfactory at 2 Ms/s.

- Reference

[6] Chapter 4.4

- Initial Condition

The IUT is set to direct RX mode. Dewhitening shall be turned off.

Frequency hopping off, fixed frequency

The value of MAX_RX_LENGTH_2M (for which the TC is performed) is specified in Section 6.7.

IUT is set for a symbol rate of 2 Ms/s.

IUT is set to assume the transmitter has a standard modulation index.

- Test Procedure

1. The IUT is set to receive at the lowest frequency for testing as defined in Section 6.2. Three test signals are fed to the IUT input port:

Wanted signal:

Modulated carrier, packets transmitted at the receiving frequency (f_{RX}) with MAX_RX_LENGTH_2M octet PRBS9 payload. Refer to Section 6.1 and [4], Section 4 for details. Signal level of the wanted signal at the IUT input port shall be -64 dBm.

Interference signal #1:

Sinusoidal, un-modulated carrier transmitted at an interferer frequency of f_1 . Signal level of the interferer signal at the IUT input port shall be -50dBm.

Interference signal #2:

Continuous modulated carrier at frequency f_2 , modulated with PRBS15 data at a symbol rate of 2 Ms/s. See Section 6.1 and [4], Section 4 for details. Signal level of the interferer signal at the IUT input port shall be -50dBm. The frequency relation between the wanted signal and the interferers shall be as follows;

$$f_{RX} = 2 \times f_1 - f_2 \text{ and } |f_2 - f_1| = n \times 2 \text{ MHz}$$

where $n=3, 4$ or 5

Once the frequency configuration is chosen, the PER is measured with the interferers both below *and* above the receive frequency, covering both cases implied by $|f_2 - f_1|$, i.e. the PER is measured twice for each receive frequency.

Figure 4.18 shows the frequency combination alternatives for the intermodulation test at 2 Ms/s.

2. The tester's transmit power is chosen such that the input power to the IUT receiver is as listed in step 1. Figure 4.15 illustrates the test setup principle.
3. The PER is measured according to Section 6.6.
4. Steps 2 and 3 are repeated when the IUT is receiving at the remaining frequencies defined in Section 6.2.

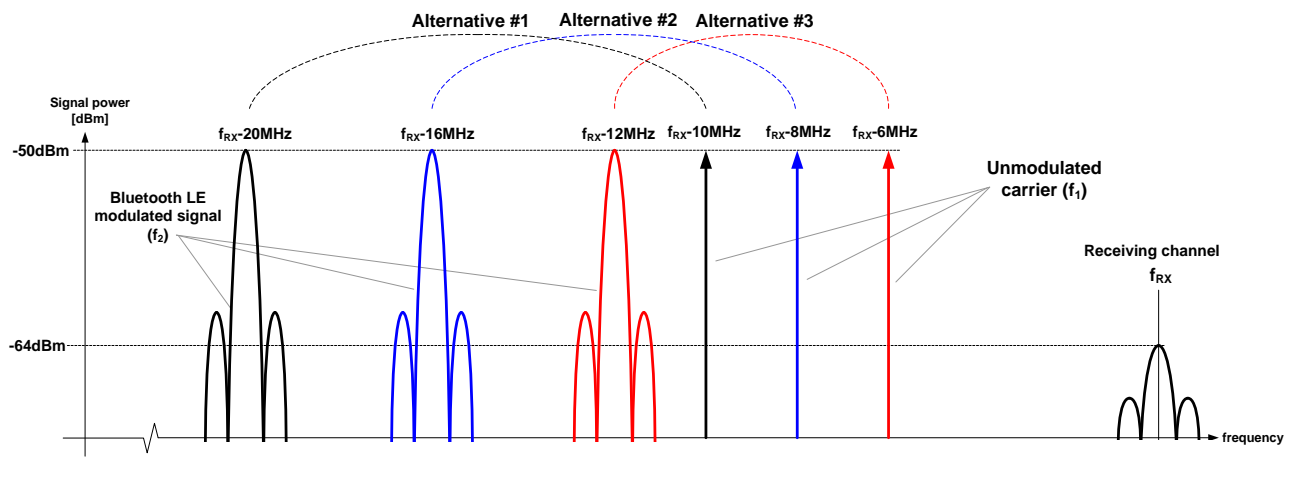


Figure 4.18: Test signal allocation alternatives in the frequency domain for 2 Ms/s. Note: figure shows only frequencies below f_0 .

- Test Condition
Common Test Case Conditions defined in Section 4.2 apply.
- Expected Outcome

Pass Verdict

The measured values fulfill the following condition:

PER better than **30.8 percent** for a minimum of **1500** packets transmitted by the tester if MAX_RX_LENGTH_2M is 37 bytes.

PER better than the value calculated according to the formula specified in Section 6.4.1 for a minimum of **1500** packets transmitted by the tester if MAX_RX_LENGTH_2M is greater than 37 bytes.

The value of n (for which the TC is performed) shall be declared by the manufacturer in the IXIT table.

4.5.11 RF-PHY/RCV/BV-12-C [Maximum input signal level at 2 Ms/s]

- Test Purpose

This test verifies that the receiver is able to demodulate a wanted 2 Ms/s signal at high signal input levels.

- Reference

[6] Chapter 4.5

- Initial Condition

As for RF-PHY/RCV/BV-06-C (Maximum input signal level), but IUT is set for a symbol rate of 2 Ms/s. IUT is set to assume the transmitter has a standard modulation index. The value of MAX_RX_LENGTH_2M (for which the TC is performed) is specified in Section 6.7.

- Test Procedure

As for RF-PHY/RCV/BV-06-C (Maximum input signal level) but wanted signal has a symbol rate of 2 Ms/s. In all steps the value MAX_RX_LENGTH_2M shall be used instead of MAX_RX_LENGTH.

- Test Condition

Common Test Case Conditions defined in Section 4.2 apply.

- Expected Outcome

Pass Verdict

All measured values fulfill the following condition:

PER better than **30.8 percent** for a minimum of **1500** packets transmitted by the tester if MAX_RX_LENGTH_2M is 37 bytes.

PER better than the value calculated according to the formula specified in Section 6.4.1 for a minimum of **1500** packets transmitted by the tester if MAX_RX_LENGTH_2M is greater than 37 bytes.

4.5.12 RF-PHY/RCV/BV-13-C [PER Report Integrity at 2 Ms/s]

- Test Purpose

This test verifies that the DUT PER report mechanism reports the correct number of received packets to the tester when operating at 2 Ms/s.

- Reference

Section 6.5

[6] Chapter 2.3



- Initial Condition

As for RF-PHY/RCV/BV-07-C (PER Report Integrity), but IUT is set for a symbol rate of 2Ms/s. IUT is set to assume the transmitter has a standard modulation index. The value of MAX_RX_LENGTH_2M (for which the TC is performed) is specified in Section 6.7.

- Test Procedure

As for RF-PHY/RCV/BV-07-C (PER Report Integrity) but transmitted packets have a symbol rate of 2 Ms/s. In all steps the value MAX_RX_LENGTH_2M shall be used instead of MAX_RX_LENGTH.

- Test Condition

Common Test Case Conditions defined in Section 4.2 apply.

- Expected Outcome

As for RF-PHY/RCV/BV-07-C (PER Report Integrity)

4.5.13 RF-PHY/RCV/BV-14-C [Receiver Sensitivity, uncoded data at 1 Ms/s, Stable Modulation Index]

- Test Purpose

This test verifies that the receiver sensitivity is within limits for non-ideal signals at normal operating conditions when receiver is set to assume the transmitter has a stable modulation index.

- Reference

[6] Chapter 4.1

- Initial Condition

As for RF-PHY/RCV/BV-01-C (Receiver Sensitivity, uncoded data at 1 Ms/s), but IUT is set to assume the transmitter has a stable modulation index.

- Test Procedure

As for RF-PHY/RCV/BV-01-C (Receiver Sensitivity, uncoded data at 1 Ms/s), except the parameters in Table 4.8 are used for each test run.

Test run	Carrier frequency offset	Modulation index	Symbol timing error
1	100 kHz	0.495	- 50 ppm
2	19 kHz	0.498	- 50 ppm
3	- 3 kHz	0.496	+ 50 ppm
4	1 kHz	0.502	+ 50 ppm
5	52 kHz	0.503	+ 50 ppm
6	0 kHz	0.504	- 50 ppm

Test run	Carrier frequency offset	Modulation index	Symbol timing error
7	- 56 kHz	0.497	- 50 ppm
8	97 kHz	0.5	- 50 ppm
9	- 25 kHz	0.495	- 50 ppm
10	- 100 kHz	0.505	+ 50 ppm

Table 4.8: Transmitter parameter settings for PER test, Stable Modulation Index

- Test Condition

Common Test Case Conditions defined in Section 4.2 apply.

- Expected Outcome

As for RF-PHY/RCV/BV-01-C (Receiver Sensitivity, uncoded data at 1 Ms/s).

4.5.14 RF-PHY/RCV/BV-15-C [C/I and Receiver Selectivity Performance, uncoded data at 1 Ms/s, Stable Modulation Index]

- Test Purpose

This test verifies the receiver's performance in presence of co-/adjacent channel interference when receiver is set to assume the transmitter has a stable modulation index.

- Reference

[6] Chapter 4.2

- Initial Condition

As for RF-PHY/RCV/BV-03-C (C/I and Receiver Selectivity Performance), but IUT is set to assume the transmitter has a stable modulation index. The IXIT value for n is taken from the IXIT values for the stable modulation receiver.

- Test Procedure

As for RF-PHY/RCV/BV-03-C (C/I and Receiver Selectivity Performance).

- Test Condition

Common Test Case Conditions defined in Section 4.2 apply.

- Expected Outcome

As for RF-PHY/RCV/BV-03-C (C/I and Receiver Selectivity Performance).

4.5.15 RF-PHY/RCV/BV-16-C [Blocking Performance, uncoded data at 1 Ms/s, Stable Modulation Index]

- Test Purpose

This test verifies that the receiver performs satisfactorily in the presence of interference sources operating outside the 2400MHz – 2483.5MHz band when receiver is set to assume the transmitter has a stable modulation index.

- Reference

[6] Chapter 4.3

- Initial Condition

As for RF-PHY/RCV/BV-04-C (Blocking Performance), but IUT is set to assume the transmitter has a stable modulation index.

- Test Procedure

As for RF-PHY/RCVBV-04-C (Blocking Performance).

- Test Condition

Common Test Case Conditions defined in Section 4.2 apply.

- Expected Outcome

As for RF-PHY/RCV/BV-04-C (Blocking Performance).

4.5.16 RF-PHY/RCV/BV-17-C [Intermodulation Performance, uncoded data at 1 Ms/s, Stable Modulation Index]

- Test Purpose

This test verifies that the receiver intermodulation performance is satisfactory when receiver is set to assume the transmitter has a stable modulation index.

- Reference

[6] Chapter 4.4

- Initial Condition

As for RF-PHY/RCV/BV-05-C (Intermodulation Performance), but IUT is set to assume the transmitter has a stable modulation index. The IXIT value for n is taken from the IXIT values for the stable modulation receiver.

- Test Procedure

As for RF-PHY/RCV/BV-05-C (Intermodulation Performance).

- Test Condition

Common Test Case Conditions defined in Section 4.2 apply.



- Expected Outcome
As for RF-PHY/RCV/BV-05-C (Intermodulation Performance).

4.5.17 RF-PHY/RCV/BV-18-C [Maximum input signal level, uncoded data at 1 Ms/s, Stable Modulation Index]

- Test Purpose
This test verifies that the receiver is able to demodulate a wanted signal at high signal input levels when receiver is set to assume the transmitter has a stable modulation index.
- Reference
[\[6\]](#) Chapter 4.5
- Initial Condition
As for RF-PHY/RCV/BV-06-C (Maximum input signal level), but IUT is set to assume the transmitter has a stable modulation index.
- Test Procedure
As for RF-PHY/RCV/BV-06-C (Maximum input signal level).
- Test Condition
Common Test Case Conditions defined in Section [4.2](#) apply.
- Expected Outcome
As for RF-PHY/RCV/BV-06-C (Maximum input signal level).

4.5.18 RF-PHY/RCV/BV-19-C [PER Report Integrity, uncoded data at 1 Ms/s, Stable Modulation Index]

- Test Purpose
This test verifies that the DUT PER report mechanism reports the correct number of received packets to the tester when receiver is set to assume the transmitter has a stable modulation index.
- Reference
Section [6.6](#)
[\[6\]](#) Chapter 2.3
- Initial Condition
As for RF-PHY/RCV/BV-07-C (PER Report Integrity), but IUT is set to assume the transmitter has a stable modulation index.
- Test Procedure
As for RF-PHY/RCV/BV-07-C (PER Report Integrity).

- Test Condition
Common Test Case Conditions defined in Section 4.2 apply.
- Expected Outcome
As for RF-PHY/RCV/BV-07-C (PER Report Integrity).

4.5.19 RF-PHY/RCV/BV-20-C [Receiver sensitivity at 2 Ms/s, Stable Modulation Index]

- Test Purpose
This test verifies that the receiver sensitivity is within limits for non-ideal signals at normal operating conditions when receiving a 2 Ms/s signal and the receiver is set to assume the transmitter has a stable modulation index.
- Reference
[\[6\]](#) Chapter 4.1
- Initial Condition
As for RF-PHY/RCV/BV-01-C (Receiver sensitivity, uncoded data at 1 Ms/s), but IUT and transmitter symbol rate is 2 Ms/s. IUT is set to assume the transmitter has a stable modulation index. The value of MAX_RX_LENGTH_2M (for which the TC is performed) is specified in Section 6.7.
- Test Procedure
As for RF-PHY/RCV/BV-01-C (Receiver sensitivity, uncoded data at 1 Ms/s), but the transmitted signal has a symbol rate of 2 Ms/s. In all steps the value MAX_RX_LENGTH_2M shall be used instead of MAX_RX_LENGTH. The parameters in [Table 4.9](#) are used for each test run.

Test run	Carrier frequency offset	Modulation index	Symbol timing error
1	100 kHz	0.495	- 50 ppm
2	19 kHz	0.498	- 50 ppm
3	- 3 kHz	0.496	+ 50 ppm
4	1 kHz	0.502	+ 50 ppm
5	52 kHz	0.503	+ 50 ppm
6	0 kHz	0.504	- 50 ppm
7	- 56 kHz	0.497	- 50 ppm
8	97 kHz	0.5	- 50 ppm
9	- 25 kHz	0.495	- 50 ppm
10	- 100 kHz	0.505	+ 50 ppm

Table 4.9: Transmitter parameter settings for PER test, Stable Modulation Index



- Test Condition

Common Test Case Conditions defined in Section 4.2 apply.

- Expected Outcome

Pass Verdict

All measured values fulfill the following condition:

PER better than **30.8 percent** for a minimum of **1500** packets transmitted by the tester if MAX_RX_LENGTH_2M is 37 bytes.

PER better than the value calculated according to the formula specified in Section 6.4.1 for a minimum of **1500** packets transmitted by the tester if MAX_RX_LENGTH_2M is greater than 37 bytes.

4.5.20 RF-PHY/RCV/BV-21-C [C/I and Receiver Selectivity Performance at 2 Ms/s, Stable Modulation Index]

- Test Purpose

This test verifies the receiver's performance in presence of co-/adjacent channel interference at 2 Ms/s when the receiver is set to assume the transmitter has a stable modulation index.

- Reference

[6] Chapter 4.2

- Initial Condition

As for RF-PHY/RCV/BV-09-C (C/I and Receiver Selectivity Performance at 2 Ms/s), but IUT is set to assume the transmitter has a stable modulation index.

- Test Procedure

As for RF-PHY/RCV/BV-09-C (C/I and Receiver Selectivity Performance at 2 Ms/s).

- Test Condition

Common Test Case Conditions defined in Section 4.2 apply.

- Expected Outcome

As for RF-PHY/RCV/BV-09-C (C/I and Receiver Selectivity Performance at 2 Ms/s).

4.5.21 RF-PHY/RCV/BV-22-C [Blocking performance at 2 Ms/s, Stable Modulation Index]

- Test Purpose

This test verifies that the receiver performs satisfactorily at 2 Ms/s in the presence of interference sources operating outside the 2400MHz – 2483.5MHz band when the receiver is set to assume the transmitter has a stable modulation index.

- Reference
[6] Chapter 4.3
- Initial Condition
As for RF-PHY/RCV/BV-10-C (Blocking performance at 2 Ms/s), but IUT is set to assume the transmitter has a stable modulation index.
- Test Procedure
As for RF-PHY/RCV/BV-10-C (Blocking performance at 2 Ms/s).
- Test Condition
Common Test Case Conditions defined in Section 4.2 apply.
- Expected Outcome
As for RF-PHY/RCV/BV-10-C (Blocking performance at 2 Ms/s).

4.5.22 RF-PHY/RCV/BV-23-C [Intermodulation performance at 2 Ms/s, Stable Modulation Index]

- Test Purpose
This test verifies that the receiver intermodulation performance is satisfactory at 2 Ms/s when the receiver is set to assume the transmitter has a stable modulation index.
- Reference
[6] Chapter 4.4
- Initial Condition
As for RF-PHY/RCV/BV-11-C (Intermodulation performance at 2 Ms/s), but IUT is set to assume the transmitter has a stable modulation index.
- Test Procedure
As for RF-PHY/RCV/BV-11-C (Intermodulation performance at 2 Ms/s).
- Test Condition
Common Test Case Conditions defined in Section 4.2 apply.
- Expected Outcome
As for RF-PHY/RCV/BV-11-C (Intermodulation performance at 2 Ms/s).

4.5.23 RF-PHY/RCV/BV-24-C [Maximum input signal level at 2 Ms/s, Stable Modulation Index]

- Test Purpose
This test verifies that the receiver is able to demodulate a wanted 2 Ms/s signal at high signal input levels when the receiver is set to assume the transmitter has a stable modulation index.



- Reference
[\[6\]](#) Chapter 4.5
- Initial Condition
As for RF-PHY/RCV/BV-12-C (Maximum input signal level at 2 Ms/s), but IUT is set to assume the transmitter has a stable modulation index.
- Test Procedure
As for RF-PHY/RCV/BV-12-C (Maximum input signal level at 2 Ms/s).
- Test Condition
Common Test Case Conditions defined in Section 4.2 apply.
- Expected Outcome
Pass Verdict
As for RF-PHY/RCV/BV-12-C (Maximum input signal level at 2 Ms/s).

4.5.24 RF-PHY/RCV/BV-25-C [PER Report Integrity at 2 Ms/s, Stable Modulation Index]

- Test Purpose
This test verifies that the DUT PER report mechanism reports the correct number of received packets to the tester when operating at 2 Ms/s and the receiver is set to assume the transmitter has a stable modulation index.
- Reference
Section 6.6
[\[6\]](#) Chapter 2.3
- Initial Condition
As for RF-PHY/RCV/BV-07-C (PER Report Integrity), but IUT is set for a symbol rate of 2Ms/s. IUT is set to assume the transmitter has a stable modulation index. The value of MAX_RX_LENGTH_2M (for which the TC is performed) is specified in Section 6.7.
- Test Procedure
As for RF-PHY/RCV/BV-07-C (PER Report Integrity) but transmitted packets have a symbol rate of 2 Ms/s. In all steps the value MAX_RX_LENGTH_2M shall be used instead of MAX_RX_LENGTH.
- Test Condition
Common Test Case Conditions defined in Section 4.2 apply.
- Expected Outcome
As for RF-PHY/RCV/BV-07-C (PER Report Integrity).

4.5.25 RF-PHY/RCV/BV-26-C [Receiver sensitivity, LE Coded (S=2)]

- Test Purpose

This test verifies that the receiver sensitivity is within limits for non-ideal signals at normal operating conditions when receiving a LE Coded signal (S=2). The non-ideal signals used in this test are within the specification limits, but deviate from the ideal case.

- Reference

[6] Chapter 4.1

- Initial Condition

- As for RF-PHY/RCV/BV-01-C (Receiver sensitivity), but the IUT is set for LE Coded PHY with data coding S=2 and a bit rate of 500kb/s. The IUT is set to assume the transmitter has a standard modulation index. The value of MAX_RX_LENGTH_CODED_S2 (for which the TC is performed) is specified in Section 6.7.
- The tester's transmit power is chosen such that the input power to the IUT receiver is -75 dBm.

- Test Procedure

As for RF-PHY/RCV/BV-01-C (Receiver sensitivity), but the transmitted signal from the Tester has a symbol rate of 1 Ms/s with data coding S=2 and a bit rate of 500kb/s. In all steps the value MAX_RX_LENGTH_CODED_S2 shall be used instead of MAX_RX_LENGTH.

- Test Condition

Common Test Case Conditions defined in Section 4.2 apply.

- Expected Outcome

Pass Verdict

All measured values fulfill the following condition:

PER better than **30.8 percent** for a minimum of **1500** packets transmitted by the tester if the IUT's MAX_RX_LENGTH_CODED_S2 is 37 bytes.

PER better than the value calculated according to the formula specified in Section 6.4.1 for a minimum of **1500** packets transmitted by the tester if the IUT's MAX_RX_LENGTH_CODED_S2 is greater than 37 bytes.

4.5.26 RF-PHY/RCV/BV-27-C [Receiver sensitivity, LE Coded (S=8)]

- Test Purpose

This test verifies that the receiver sensitivity is within limits for non-ideal signals at normal operating conditions when receiving a LE Coded signal (S=8). The non-ideal signals used in this test are within the specification limits, but deviate from the ideal case.

- Reference

[6] Chapter 4.1



- Initial Condition
 - As for RF-PHY/RCV/BV-01-C (Receiver sensitivity), but the IUT is set for LE Coded PHY with data coding S=8 and a bit rate of 125kb/s. The IUT is set to assume the transmitter has a standard modulation index. The value of MAX_RX_LENGTH_CODED_S8 (for which the TC is performed) is specified in Section 6.7.
 - The tester's transmit power is chosen such that the input power to the IUT receiver is -82 dBm.
- Test Procedure

As for RF-PHY/RCV/BV-01-C, but the transmitted signal has a symbol rate of 1 Ms/s with data coding S=8 and a bit rate of 125kb/s. In all steps the value MAX_RX_LENGTH_CODED_S8 shall be used instead of MAX_RX_LENGTH.
- Test Condition

Common Test Case Conditions defined in Section 4.2 apply.
- Expected Outcome

Pass Verdict

All measured values fulfill the following condition:

PER better than **30.8 percent** for a minimum of **1500** packets transmitted by the tester if the IUT's MAX_RX_LENGTH_CODED_S8 is 37 bytes.

PER better than the value calculated according to the formula specified in Section 6.4.1 for a minimum of **1500** packets transmitted by the tester if the IUT's MAX_RX_LENGTH_CODED_S8 is greater than 37 bytes.

4.5.27 RF-PHY/RCV/BV-28-C [C/I and Receiver Selectivity Performance, LE Coded (S=2)]

- Test Purpose

This test verifies the receiver's performance in presence of co-/adjacent channel interference when receiving an LE Coded signal (S=2). The receiver mirror image rejection performance is also verified in this test.
- Reference

[6] Chapter 4.2
- Initial Condition
 - Refer to [Figure 4.19](#) for test setup principle.
 - The IUT is set to direct RX mode. Dewhitening shall be turned off.
 - Frequency hopping off, fixed frequency.
 - The image frequency (fimage) of the receiver relative to the receiver frequency is declared by the equipment manufacturer as an IXIT value.
 - The value of MAX_RX_LENGTH_CODED_S2 (for which the TC is performed) is specified in Section 6.7.

- The IUT is set for LE Coded PHY with data coding S=2 and a bit rate of 500kb/s.
- The IUT is set to assume the transmitter has a standard modulation index.
- Test Procedure
 1. The IUT is set to receive at the low operating frequency listed in Section 6.2.
 2. Two test signals are fed to the IUT input port:

Wanted signal:

Packets transmitted at the receiving frequency (f_{RX}) with MAX_RX_LENGTH_CODED_S2 octet PRBS9 payload using the LE Coded PHY. Refer to Section 6.1 and [4], Section 4 for details. Signal level of the wanted signal at the IUT input port shall be -72 dBm.

Interference signal:

Continuous modulated carrier at 2400MHz, modulated and coded with PRBS15 data at a symbol rate of 1 Ms/s and S=2. Refer to Section 6.1 and [4], Section 4 for details. Signal level of the interference signal at the IUT input port and frequency relative to the receiving frequency shall be as defined in Table 4.10.

3. The tester's transmit power is chosen such that the input power to the IUT receiver is as listed in Table 4.10.
4. Steps 2 to 3 are repeated for interference frequencies $2400\text{MHz} + N \cdot \text{MHz}$ where $N=1,2,3 \dots 83$.
5. The PER is measured according to Section 6.6.
6. Steps 2 to 5 are repeated when the IUT is receiving at the mid- and high operation frequencies listed in Section 6.2.

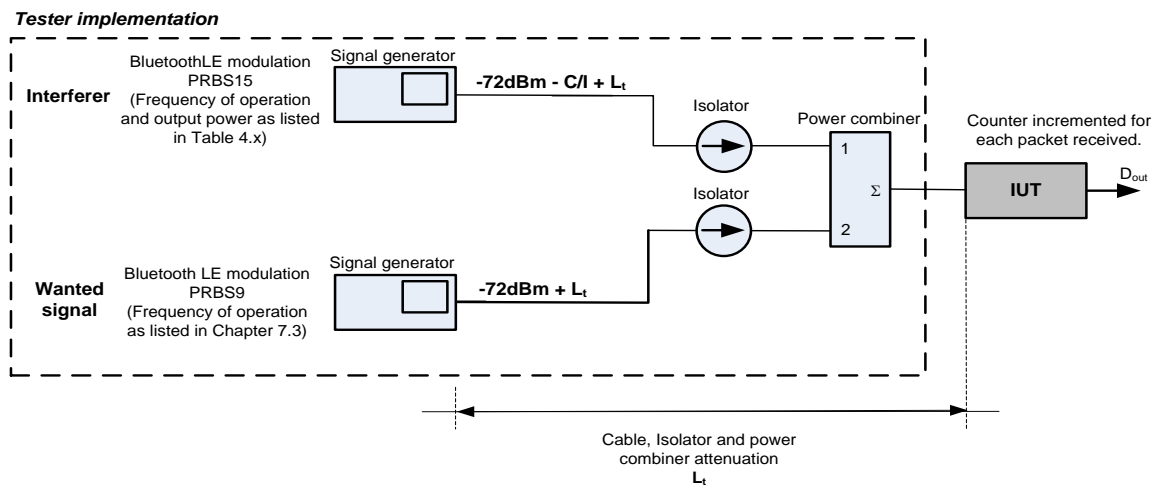


Figure 4.19: C/I- and receiver selectivity test implementation principle for LE Coded PHY (S=2)

Interference signal frequency ³	Interferer signal level at IUT input port	Wanted signal level relative to interference signal level (C/I requirement)
Co-channel ($f_{RX} = f_{interference}$)	-89 dBm	17 dB

³ If two frequencies defined in Table 4.10 refer to the same physical channel, the less stringent requirement applies.

Interference signal frequency ³	Interferer signal level at IUT input port	Wanted signal level relative to interference signal level (C/I requirement)
Adjacent channel; $f_{\text{interference}} = f_{\text{RX}} \pm 1 \text{ MHz}$	-83 dBm	11 dB
Adjacent channel; $f_{\text{interference}} = f_{\text{RX}} \pm 2 \text{ MHz}$	-51 dBm	-21 dB
Adjacent channel; $f_{\text{interference}} = f_{\text{RX}} \pm (3+n) \text{ MHz}$ [n=0,1,2...]	-41 dBm	-31 dB
Image frequency; $f_{\text{interference}} = f_{\text{image}}$	-59 dBm	-13 dB
Adjacent channel to image frequency; $f_{\text{interference}} = f_{\text{image}} \pm 1 \text{ MHz}$	-53 dBm	-19 dB

Table 4.10: C/I- and receiver selectivity test parameter settings for LE Coded PHY (S=2).

- Test Condition

Common Test Case Conditions defined in Section 4.2 apply.

- Expected Outcome

Pass Verdict

All measured values fulfill the following condition:

PER better than **30.8 percent** for a minimum of **1500** packets transmitted by the tester if the IUT's MAX_RX_LENGTH_CODED_S2 is 37 bytes.

PER better than the value calculated according to the formula specified in Section 6.4.1 for a minimum of **1500** packets transmitted by the tester if the IUT's MAX_RX_LENGTH_CODED_S2 is greater than 37 bytes.

For each individual measurement the C/I requirement may be relaxed for a maximum of five interference frequency settings. The C/I-performance shall in this case be equal to, or better than -17 dB (Interference level at least 17 dB higher than wanted signal level). This relaxation applies to the following measurements:

- Adjacent channel $\pm 2 \text{ MHz}$
- Adjacent channel $\pm (3+n) \text{ MHz}$ [n=0,1,2...]

4.5.28 RF-PHY/RCV/BV-29-C [C/I and Receiver Selectivity Performance, LE Coded (S=8)]

- Test Purpose

This test verifies the receiver's performance in presence of co-/adjacent channel interference. The receiver mirror image rejection performance is also verified in this test.

- Reference

[6] Chapter 4.2

- Initial Condition

- Refer to [Figure 4.20](#) for test setup principle.
- The IUT is set to direct RX mode. Dewhitening shall be turned off.
- Frequency hopping off, fixed frequency.
- The image frequency (f_{image}) of the receiver relative to the receiver frequency is declared by the equipment manufacturer as an IXIT value.
- The value of MAX_RX_LENGTH_CODED_S8 (for which the TC is performed) is specified in [Section 6.7](#).
- The IUT is set for LE Coded PHY with data coding S=8 and a bit rate of 125kb/s.
- The IUT is set to assume the transmitter has a standard modulation index.

- Test Procedure

1. The IUT is set to receive at the low operating frequency listed in [Section 6.2](#).
2. Two test signals are fed to the IUT input port:

Wanted signal:

Packets transmitted at the receiving frequency (f_{RX}) with MAX_RX_LENGTH_CODED_S8 octet PRBS9 payload using the LE Coded PHY. Refer to [Section 6.1](#) and [\[4\]](#), Section 4 for details. Signal level of the wanted signal at the IUT input port shall be -79dBm.

Interference signal:

Continuous modulated carrier at 2400MHz, modulated and coded with PRBS15 data at a symbol rate of 1 Ms/s and S=8. Refer to [Section 6.1](#) and [\[4\]](#), Section 4 for details. Signal level of the interference signal at the IUT input port and frequency relative to the receiving frequency shall be as defined in [Table 4.11](#).

3. The tester's transmit power is chosen such that the input power to the IUT receiver is as listed in [Table 4.7](#).
4. Steps 2 to 3 are repeated for interference frequencies 2400MHz+N·MHz where N=1,2,3...83.
5. The PER is measured according to [Section 6.6](#).
6. Steps 2 to 5 are repeated when the IUT is receiving at the mid- and high operation frequencies listed in [Section 6.2](#).

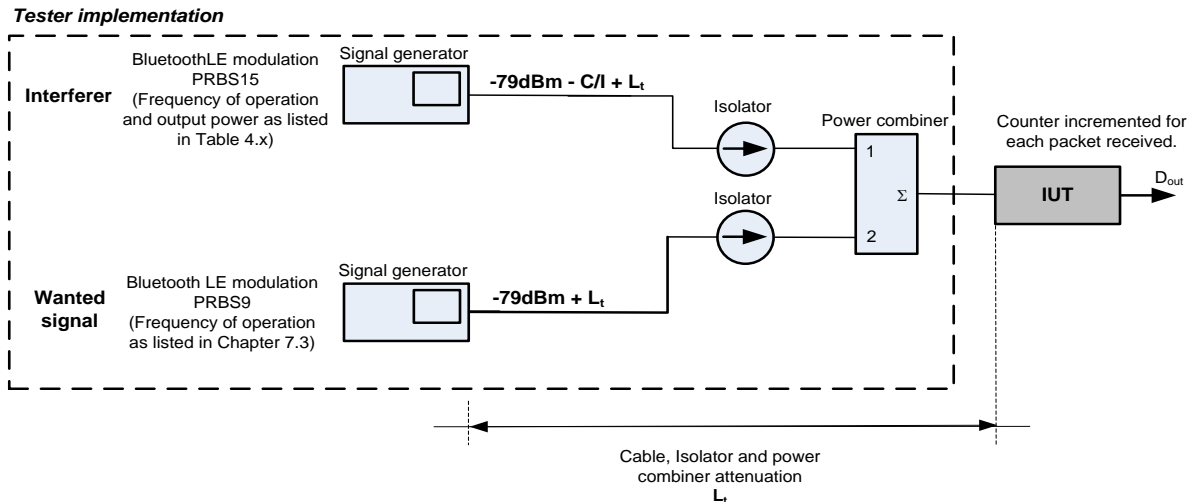


Figure 4.20: C/I- and receiver selectivity test implementation principle for LE Coded PHY (S=8)

Interference signal frequency ⁴	Interferer signal level at IUT input port	Wanted signal level relative to interference signal level (C/I requirement)
Co-channel ($f_{RX} = f_{interference}$)	-91 dBm	12 dB
Adjacent channel; $f_{interference} = f_{RX} \pm 1 \text{ MHz}$	-85 dBm	6 dB
Adjacent channel; $f_{interference} = f_{RX} \pm 2 \text{ MHz}$	-53 dBm	-26 dB
Adjacent channel; $f_{interference} = f_{RX} \pm (3+n) \text{ MHz}$ [$n=0,1,2\dots$]	-43 dBm	-36 dB
Image frequency; $f_{interference} = f_{image}$	-61 dBm	-18 dB
Adjacent channel to image frequency; $f_{interference} = f_{image} \pm 1 \text{ MHz}$	-55 dBm	-24 dB

Table 4.11: C/I- and receiver selectivity test parameter settings for LE Coded PHY (S=8).

- Test Condition

Common Test Case Conditions defined in Section 4.2 apply.

4 If two frequencies defined in Table 4.11 refer to the same physical channel, the less stringent requirement applies.

- Expected Outcome

Pass Verdict

All measured values fulfill the following condition:

PER better than **30.8 percent** for a minimum of **1500** packets transmitted by the tester if the IUT's MAX_RX_LENGTH_CODED_S8 is 37 bytes.

PER better than the value calculated according to the formula specified in Section 6.4.1 for a minimum of **1500** packets transmitted by the tester if the IUT's MAX_RX_LENGTH_CODED_S8 is greater than 37 bytes.

For each individual measurement the C/I requirement may be relaxed for a maximum of five interference frequency settings. The C/I-performance shall in this case be equal to, or better than -17 dB (Interference level at least 17 dB higher than wanted signal level). This relaxation applies to the following measurements:

- Adjacent channel ± 2 MHz
- Adjacent channel $\pm (3+n)$ MHz [$n=0,1,2\dots$]

4.5.29 RF-PHY/RCV/BV-30-C [PER Report Integrity, LE Coded (S=2)]

- Test Purpose

This test verifies that the DUT PER report mechanism reports the correct number of received packets to the tester when operating using the LE Coded PHY with data coding S=2.

- Reference

Section 6.5

[6] Chapter 2.3

- Initial Condition

As for RF-PHY/RCV/BV-07-C (PER Report Integrity), but the IUT is set for LE Coded PHY with data coding S=2. The IUT is set to assume the transmitter has a standard modulation index. The value of MAX_RX_LENGTH_CODED_S2 (for which the TC is performed) is specified in Section 6.7.

- Test Procedure

As for RF-PHY/RCV/BV-07-C (PER Report Integrity) but transmitted packets are sent using the LE Coded PHY with data coding S=2. In all steps the value MAX_RX_LENGTH_CODED_S2 shall be used instead of MAX_RX_LENGTH.

- Test Condition

Common Test Case Conditions defined in Section 4.2 apply.

- Expected Outcome

As for RF-PHY/RCV/BV-07-C (PER Report Integrity)



4.5.30 RF-PHY/RCV/BV-31-C [PER Report Integrity, LE Coded (S=8)]

- Test Purpose

This test verifies that the DUT PER report mechanism reports the correct number of received packets to the tester when operating using the LE Coded PHY with data coding S=8.

- Reference

Section 6.5

[6] Chapter 2.3

- Initial Condition

As for RF-PHY/RCV/BV-07-C (PER Report Integrity), but the IUT is set for LE Coded PHY with data coding S=8. The IUT is set to assume the transmitter has a standard modulation index. The value of MAX_RX_LENGTH_CODED_S8 (for which the TC is performed) is specified in Section 6.7.

- Test Procedure

As for RF-PHY/RCV/BV-07-C (PER Report Integrity) but transmitted packets are sent using the LE Coded PHY with data coding S=8. In all steps the value MAX_RX_LENGTH_CODED_S8 shall be used instead of MAX_RX_LENGTH.

- Test Condition

Common Test Case Conditions defined in Section 4.2 apply.

- Expected Outcome

As for RF-PHY/RCV/BV-07-C (PER Report Integrity)

4.5.31 RF-PHY/RCV/BV-32-C [Receiver sensitivity, LE Coded (S=2), Stable Modulation Index]

- Test Purpose

This test verifies that the receiver sensitivity is within limits for non-ideal signals at normal operating conditions when receiving an LE Coded PHY signal (S=2) and the receiver is set to assume the transmitter has a stable modulation index.

- Reference

[6] Chapter 4.1

- Initial Condition

- As for RF-PHY/RCV/BV-01-C (Receiver sensitivity), but the IUT is set for LE Coded PHY with data coding S=2 and a bit rate of 500kb/s. The IUT is set to assume the transmitter has a stable modulation index. The value of MAX_RX_LENGTH_CODED_S2 (for which the TC is performed) is specified in Section 6.7.
- The tester's transmit power is chosen such that the input power to the IUT receiver is -75 dBm.

- Test Procedure

As for RF-PHY/RCV/BV-01-C (Receiver sensitivity), but the transmitted signal uses the LE Coded PHY at 500kb/s data rate. In all steps the value MAX_RX_LENGTH_CODED_S2 shall be used. The parameters in [Table 4.12](#) are used for each test run.

Test run	Carrier frequency offset	Modulation index	Symbol timing error
1	100 kHz	0.495	- 50 ppm
2	19 kHz	0.498	- 50 ppm
3	- 3 kHz	0.496	+ 50 ppm
4	1 kHz	0.502	+ 50 ppm
5	52 kHz	0.503	+ 50 ppm
6	0 kHz	0.504	- 50 ppm
7	- 56 kHz	0.497	- 50 ppm
8	97 kHz	0.5	- 50 ppm
9	- 25 kHz	0.495	- 50 ppm
10	- 100 kHz	0.505	+ 50 ppm

Table 4.12: Transmitter parameter settings for PER test, LE Coded PHY (S=2), Stable Modulation Index

- Test Condition

Common Test Case Conditions defined in [Section 4.2](#) apply.

- Expected Outcome

Pass Verdict

All measured values fulfill the following condition:

PER better than **30.8 percent** for a minimum of **1500** packets transmitted by the tester if the IUT's MAX_RX_LENGTH_CODED_S2 is 37 bytes.

PER better than the value calculated according to the formula specified in [Section 6.4.1](#) for a minimum of **1500** packets transmitted by the tester if MAX_RX_LENGTH_CODED_S2 is greater than 37 bytes.

4.5.32 RF-PHY/RCV/BV-33-C [Receiver sensitivity, LE Coded (S=8), Stable Modulation Index]

- Test Purpose

This test verifies that the receiver sensitivity is within limits for non-ideal signals at normal operating conditions when receiving LE Coded PHY signal (S=8) and the receiver is set to assume the transmitter has a stable modulation index.



- Reference

[6] Chapter 4.1

- Initial Condition

As for RF-PHY/RCV/BV-01-C (Receiver sensitivity), but the IUT is set for LE Coded PHY with data coding S=8 and a bit rate of 125kb/s. The IUT is set to assume the transmitter has a stable modulation index. The value of MAX_RX_LENGTH_CODED_S8 (for which the TC is performed) is specified in Section 6.7.

The tester's transmit power is chosen such that the input power to the IUT receiver is -82 dBm.

- Test Procedure

As for RF-PHY/RCV/BV-01-C (Receiver sensitivity), but the transmitted signal uses the LE Coded PHY at 125kb/s data rate. In all steps MAX_RX_LENGTH_CODED_S8 shall be used. The parameters in Table 4.13 are used for each test run.

Test run	Carrier frequency offset	Modulation index	Symbol timing error
1	100 kHz	0.495	- 50 ppm
2	19 kHz	0.498	- 50 ppm
3	- 3 kHz	0.496	+ 50 ppm
4	1 kHz	0.502	+ 50 ppm
5	52 kHz	0.503	+ 50 ppm
6	0 kHz	0.504	- 50 ppm
7	- 56 kHz	0.497	- 50 ppm
8	97 kHz	0.5	- 50 ppm
9	- 25 kHz	0.495	- 50 ppm
10	- 100 kHz	0.505	+ 50 ppm

Table 4.13: Transmitter parameter settings for PER test, LE Coded PHY (S=8), Stable Modulation Index

- Test Condition

Common Test Case Conditions defined in Section 4.2 apply.

- Expected Outcome

Pass Verdict

All measured values fulfill the following condition:

PER better than **30.8 percent** for a minimum of **1500** packets transmitted by the tester if the IUT's MAX_RX_LENGTH_CODED_S8 is 37 bytes.



PER better than the value calculated according to the formula specified in Section 6.4.1 for a minimum of **1500** packets transmitted by the tester if MAX_RX_LENGTH_CODED_S8 is greater than 37 bytes.

4.5.33 RF-PHY/RCV/BV-34-C [C/I and Receiver Selectivity Performance, LE Coded (S=2), Stable Modulation Index]

- Test Purpose

This test verifies the receiver's performance in presence of co-/adjacent channel interference when receiving an LE Coded signal (S=2) and the receiver is set to assume transmitter has a stable modulation index.

- Reference

[6] Chapter 4.2

- Initial Condition

As for RF-PHY/RCV/BV-28-C (C/I and Receiver Selectivity Performance, LE Coded (S=2)), but the IUT is set to assume the transmitter has a stable modulation index. The IXIT value for n is taken from the IXIT values for the stable modulation receiver.

- Test Procedure

As for RF-PHY/RCV/BV-28-C (C/I and Receiver Selectivity Performance, LE Coded (S=2)).

- Test Condition

Common Test Case Conditions defined in Section 4.2 apply.

- Expected Outcome

As for RF-PHY/RCV/BV-28-C (C/I and Receiver Selectivity Performance, LE Coded (S=2)).

4.5.34 RF-PHY/RCV/BV-35-C [C/I and Receiver Selectivity Performance, LE Coded (S=8), Stable Modulation Index]

- Test Purpose

This test verifies the receiver's performance in presence of co-/adjacent channel interference when receiving an LE Coded signal (S=8) and the receiver is set to assume transmitter has a stable modulation index.

- Reference

[6] Chapter 4.2

- Initial Condition

As for RF-PHY/RCV/BV-29-C (C/I and Receiver Selectivity Performance, LE Coded (S=8)), but the IUT is set to assume the transmitter has a stable modulation index. The IXIT value for n is taken from the IXIT values for the stable modulation receiver.

- Test Procedure

As for RF-PHY/RCV/BV-29-C (C/I and Receiver Selectivity Performance, LE Coded (S=8)).



- Test Condition
Common Test Case Conditions defined in Section 4.2 apply.

- Expected Outcome
As for RF-PHY/RCV/BV-29-C (C/I and Receiver Selectivity Performance, LE Coded (S=8)).

4.5.35 RF-PHY/RCV/BV-36-C [PER Report Integrity, LE Coded (S=2), Stable Modulation Index]

- Test Purpose
This test verifies that the DUT PER report mechanism reports the correct number of received packets to the tester when receiving LE Coded packets (S=2) and the receiver is set to assume transmitter has a stable modulation index.
- Reference
Section 6.6
[\[6\]](#) Chapter 2.3
- Initial Condition
As for RF-PHY/RCV/BV-07-C (PER Report Integrity), but the IUT is set to use the LE Coded PHY with data coding S=2. The IUT is set to assume the transmitter has a stable modulation index. The value of MAX_RX_LENGTH_CODED_S2 (for which the TC is performed) is specified in Section 6.7.
- Test Procedure
As for RF-PHY/RCV/BV-07-C (PER Report Integrity) but transmitted packets use the LE Coded PHY with data coding S=2. In all steps the value MAX_RX_LENGTH_CODED_S2 shall be used instead of MAX_RX_LENGTH.
- Test Condition
Common Test Case Conditions defined in Section 4.2 apply.
- Expected Outcome
As for RF-PHY/RCV/BV-07-C (PER Report Integrity).

4.5.36 RF-PHY/RCV/BV-37-C [PER Report Integrity, LE Coded (S=8), Stable Modulation Index]

- Test Purpose
This test verifies that the DUT PER report mechanism reports the correct number of received packets to the tester when receiving LE Coded packets (S=8) and the receiver is set to assume transmitter has a stable modulation index.
- Reference
Section 6.6
[\[6\]](#) Chapter 2.3



- Initial Condition

As for RF-PHY/RCV/BV-07-C (PER Report Integrity), but the IUT is set to use the LE Coded PHY with data coding S=8. The IUT is set to assume the transmitter has a stable modulation index. The value of MAX_RX_LENGTH_CODED_S8 (for which the TC is performed) is specified in Section 6.7.
- Test Procedure

As for RF-PHY/RCV/BV-07-C (PER Report Integrity) but transmitted packets use the LE Coded PHY with data coding S=8. In all steps the value MAX_RX_LENGTH_CODED_S8 shall be used instead of MAX_RX_LENGTH.
- Test Condition

Common Test Case Conditions defined in Section 4.2 apply.
- Expected Outcome

As for RF-PHY/RCV/BV-07-C (PER Report Integrity).

4.5.37 IQ Samples Coherency, AoD Receiver

- Test Purpose

This test group is for generic use and contains four test cases to verify that the measured relative phase values derived from the I and Q values sampled on an IUT AoD Receiver from a Constant Tone Extension are within specified limits.
- Reference

[8] Section 5

[9] Section 4.1.7
- Initial Condition
 - The IUT is set to direct RX mode. Dewhitening shall be turned off.
 - Frequency hopping off, fixed frequency.
 - The Lower Tester's transmit power is chosen such that the input power to the IUT receiver is -67 dBm. The Lower Tester does not change its transmit power during the Constant Tone Extension (except during the guard period and the switch slots).
 - The IUT is set to assume the transmitter has a standard modulation index.
 - IUT is set for a symbol rate as specified in Table 4.14.
 - The rate at which the IUT generates IQ reports (TSPX_IQ_Report_Rate) is defined in the IXIT [10].
- Test Procedure
 1. The Upper Tester commands the IUT to receive test packets at the lowest frequency for testing as defined in Section 6.2, with expected CTE length of 20 and expected CTE type as specified in Table 4.14.
 2. The Lower Tester transmits LE test packets with no PDU payload and with $20 * 8 \mu\text{s}$ Constant Tone Extension. Antenna switching is executed for each Constant Tone Extension with slot durations as specified in Table 4.14, length of switching pattern and switching pattern set as

described in Section 5.2.3 [8] with the number of antenna elements set to 4. See [9] Section 4, “LE Test Packet Definition” for details.

3. The Upper Tester expects to receive HCI_LE_Connectionless_IQ_Report events at the rate specified by TSPX_IQ_Report_Rate and calculates the relative phase and reference phase deviation values for each non-reference antenna, as described in Section 5.2.1 [8].
 4. The Lower Tester transmits LE test packets until it reaches the maximum number of packets defined in Section 6.8 or until the RP(m) and RPD sets each contain at least 10,000 values.
 5. Repeat steps 1–4 until the IUT has received on all the remaining frequencies defined in Section 6.2.
- Test Condition

The IUT and Lower Tester are set up according to the cabled testing setup described in Section 4.6 and common Test Case Conditions defined in Section 4.2 apply.

- Expected Outcome

Pass Verdict

For each frequency tested, the IUT reports at least 10,000 valid IQ sample pairs per antenna, except for antenna index 1, to the Upper Tester.

For each frequency tested, the IUT meets the requirements from Section 5.2.2 [8].

The presence of invalid IQ samples does not constitute a failure.

Test Case	PHY	CTE Type (Slot Duration)
4.5.37.1 RF-PHY/RCV/IQC/BV-01-C [IQ Samples Coherency, AoD Receiver at 1 Ms/s with 2 μs Slot]	1 Ms/s	(0x02) 2 μ s
4.5.37.2 RF-PHY/RCV/IQC/BV-02-C [IQ Samples Coherency, AoD Receiver at 1 Ms/s with 1 μs Slot]	1 Ms/s	(0x01) 1 μ s
4.5.37.3 RF-PHY/RCV/IQC/BV-03-C [IQ Samples Coherency, AoD Receiver at 2 Ms/s with 2 μs Slot]	2 Ms/s	(0x02) 2 μ s
4.5.37.4 RF-PHY/RCV/IQC/BV-04-C [IQ Samples Coherency, AoD Receiver at 2 Ms/s with 1 μs Slot]	2 Ms/s	(0x01) 1 μ s

Table 4.14: IQ Samples Coherency, AoD Receiver Test Cases

4.5.38 IQ Samples Coherency, AoA Receiver

- Test Purpose

This test group is for generic use and contains two test cases to verify that the measured relative phase values derived from the I and Q values sampled on an IUT AoA Receiver from a Constant Tone Extension are within specified limits.

- Reference

[8] Section 5

[9] Section 4.1.7



- Initial Condition
 - The IUT is set to direct RX mode. Dewhitening shall be turned off.
 - Frequency hopping off, fixed frequency.
 - The Lower Tester's transmit power is chosen such that the input power to the IUT receiver is -67 dBm. The Lower Tester does not change its transmit power during the Constant Tone Extension (except during the guard period and the switch slots).
 - The IUT is set to assume the transmitter has a standard modulation index.
 - IUT is set for a symbol rate as specified in [Table 4.15](#).
 - The maximum number of antennas supported by the IUT (TSPX_number_of_antennae) is defined in the IXIT [\[10\]](#).
 - The rate at which the IUT generates IQ reports (TSPX_IQ_Report_Rate) is defined in the IXIT [\[10\]](#).
- Test Procedure
 1. The Upper Tester commands the IUT to receive test packets at the lowest frequency for testing as defined in [Section 6.2](#), with expected CTE length of 20, CTE type of 0x00 (AoA CTE), slot durations of 2 μ s, length of switching pattern and the switching pattern set as described in [Section 5.2.3 \[8\]](#) with the number of antenna elements set to the minimum value between 4 and TSPX_number_of_antennae.
 2. The Lower Tester transmits LE test packets with no PDU payload and with 20 * 8 μ s Constant Tone Extension. See [\[9\]](#) [Section 4](#), "LE Test Packet Definition" for details.
 3. The Upper Tester expects to receive HCI_LE_Connectionless_IQ_Report events at the rate specified by TSPX_IQ_Report_Rate and calculates the relative phase and reference phase deviation values for each non-reference antenna, as described in [Section 5.2.1 \[8\]](#).
 4. The Lower Tester transmits LE test packets until it reaches the maximum number of packets defined in [Section 6.8](#) or until the RP(m) and RPD sets each contain at least 10,000 values.
 5. Repeat steps 1–4 until the IUT has received on all the remaining frequencies defined in [Section 6.2](#).

- Test Condition

The IUT and Lower Tester are set up according to the cabled testing setup described in [Section 4.6](#) and common Test Case Conditions defined in [Section 4.2](#) apply.

- Expected Outcome

Pass Verdict

For each frequency tested, the IUT reports at least 10,000 valid IQ sample pairs per antenna, except for antenna index 1, to the Upper Tester.

For each frequency tested, the IUT meets the requirements from [Section 5.2.2 \[8\]](#).

The presence of invalid IQ samples does not constitute a failure.

Test Case	PHY
4.5.38.1 RF-PHY/RCV/IQC/BV-05-C [IQ Samples Coherency, AoA Receiver at 1 Ms/s with 2 μs Slot]	1 Ms/s
4.5.38.2 RF-PHY/RCV/IQC/BV-06-C [IQ Samples Coherency, AoA Receiver at 2 Ms/s with 2 μs Slot]	2 Ms/s

Table 4.15: IQ Samples Coherency, AoA Receiver Test Cases

4.5.39 IQ Samples Dynamic Range, AoD Receiver

- Test Purpose

This test group is for generic use and contains four test cases to verify that the I and Q values sampled on receiving an AoD Constant Tone Extension from a peer device have specified values when varying the dynamic range of the Constant Tone Extension and marks any invalid samples as invalid.

- Reference

[\[8\]](#) Section 5

[\[9\]](#) Section 4.1.7

- Initial Condition

- The IUT is set to direct RX mode. Dewhitening shall be turned off.
- The IUT is set to assume the transmitter has a standard modulation index.
- IUT is set for a symbol rate as specified in [Table 4.17](#).
- Frequency hopping off, fixed frequency.
- The rate at which the IUT generates IQ reports (TSPX_IQ_Report_Rate) is defined in the IXIT [\[10\]](#).

- Test Procedure

1. The Upper Tester commands the IUT to receive test packets at the lowest frequency for testing as defined in [Section 6.2](#), with expected CTE length of 20 and expected CTE type as specified in [Table 4.17](#).
2. The Lower Tester transmits LE test packets with no PDU payload and with 20 * 8 μ s Constant Tone Extension. The Lower Tester applies an attenuation on the line while sending the Preamble, preamble, synchronization word, LE test packet PDU, and CRC, such that the input power to the IUT receiver is set to the value described in [Table 4.16](#) for antenna index 0. Antenna switching is executed for each Constant Tone Extension with slot durations as specified in [Table 4.17](#), length of switching pattern and the switching pattern set as described in [Section 5.2.3 \[8\]](#) with the number of antenna elements set to 4. See [\[9\]](#) Section 4, "LE Test Packet Definition" for details.
3. The Lower Tester controls a variable attenuator that applies an additional attenuation on the line while sending the Constant Tone Extension, such that the input power to the IUT receiver is set to the value described in [Table 4.16](#) for each antenna index.

4. The Upper Tester expects to receive HCI_LE_Connectionless_IQ_Report events at the rate specified by TSPX_IQ_Report_Rate and calculates amplitude $A = \sqrt{I^2 + Q^2}$ for each valid sample that was not taken during the reference period.
5. The Lower Tester transmits LE test packets until it reaches the maximum number of packets defined in Section 6.8 or until the RP(m) and RPD sets each contain at least 10,000 values.
6. Repeat steps 1–5 until the IUT has received on all the remaining frequencies defined in Section 6.2.

Antenna Index	Input Power (dBm)
0	-52
1	-49
2	-57
3	-62

Table 4.16: Input Power values for each antenna index

- Test Condition

The IUT and Lower Tester are set up according to the cabled testing setup described in Section 4.6 and common Test Case Conditions defined in Section 4.2 apply.

- Expected Outcome

Pass Verdict

For each frequency tested, the mean of amplitudes measured for each Lower Tester antenna index 'i' from Table 4.16 follows the equation:

$$\text{mean}_{\text{ANT3}} < \text{mean}_{\text{ANT2}} < \text{mean}_{\text{ANT0}} < \text{mean}_{\text{ANT1}}$$

Should there be no valid samples in the non-reference antenna 1, due to saturation, then the pass verdict shall be:

$$\text{mean}_{\text{ANT3}} < \text{mean}_{\text{ANT2}} < \text{mean}_{\text{ANT0}}$$

For each frequency tested, the IUT reports at least 10,000 valid IQ sample pairs per antenna, except for antenna index 1, to the Upper Tester.

The presence of invalid I or Q samples does not constitute a failure.

Test Case	PHY	CTE Type (Slot Duration)
4.5.39.1 RF-PHY/RCV/IQDR/BV-07-C [IQ Samples Dynamic Range, AoD Receiver at 1 Ms/s with 2 µs Slot]	1 Ms/s	(0x02) 2 µs
4.5.39.2 RF-PHY/RCV/IQDR/BV-08-C [IQ Samples Dynamic Range, AoD Receiver at 1 Ms/s with 1 µs Slot]	1 Ms/s	(0x01) 1 µs
4.5.39.3 RF-PHY/RCV/IQDR/BV-09-C [IQ Samples Dynamic Range, AoD Receiver at 2 Ms/s with 2 µs Slot]	2 Ms/s	(0x02) 2 µs
4.5.39.4 RF-PHY/RCV/IQDR/BV-10-C [IQ Samples Dynamic Range, AoD Receiver at 2 Ms/s with 1 µs Slot]	2 Ms/s	(0x01) 1 µs

Table 4.17: IQ Samples Dynamic Range, AoD Receiver Test Cases

4.5.40 IQ Samples Dynamic Range, AoA Receiver

- Test Purpose

This test group is for generic use and contains two test cases to verify that the I and Q values sampled on receiving an AoA Constant Tone Extension from a peer device have specified values when varying the dynamic range of the Constant Tone Extension and marks any invalid samples as invalid.

- Reference

[8] Section 5

[9] Section 4.1.7

- Initial Condition

- The IUT is set to direct RX mode at maximum output power. Whitening shall be turned off.
- Frequency hopping off, fixed frequency.
- The IUT is set to assume the transmitter has a standard modulation index.
- IUT is set for a symbol rate as specified in [Table 4.19](#).
- The maximum number of antennas supported by the IUT (TSPX_number_of_antennae) and the rate at which the IUT generates IQ reports (TSPX_Report_Rate) are defined in the IXIT [\[10\]](#).

- Test Procedure

- The Upper Tester commands the IUT to receive test packets at the lowest frequency for testing as defined in [Section 6.2](#), with expected CTE length of 20, CTE type of 0x00 (AoA CTE), slot durations of 0x02 (2 µs), length of switching pattern and the switching pattern set as described in [Section 5.2.3 \[8\]](#) with the number of antenna elements set to the minimum value between 4 and TSPX_number_of_antennae.
- The Lower Tester transmits LE test packets with no PDU payload and with 20 * 8 µs Constant Tone Extension. The Lower Tester applies an attenuation on the line while sending the preamble, synchronization word, LE test packet PDU, and CRC, such that the input power to the IUT receiver is set to the value described in [Table 4.18](#) for antenna index 0. See [\[9\] Section 4](#), “LE Test Packet Definition” for details.

3. The Lower Tester controls a variable attenuator that applies an additional attenuation on the line while sending the Constant Tone Extension, such that the input power to the IUT receiver is set to the value described in [Table 4.18](#) for each antenna index.
4. The Upper Tester expects to receive HCI_LE_Connectionless_IQ_Report events at the rate specified by TSPX_IQ_Report_Rate and calculates the amplitude $A = \sqrt{I^2 + Q^2}$ for each valid sample that was not taken during the reference period.
5. The Lower Tester transmits LE test packets until it reaches the maximum number of packets defined in [Section 6.8](#) or until the RP(m) and RPD sets each contain at least 10,000 values.
6. Repeat steps 1–5 until the IUT has received on all the remaining frequencies defined in [Section 6.2](#).

Antenna Index	Input Power (dBm)
0	-52
1	-49
2	-57
3	-62

Table 4.18: Input Power values for each antenna index

- Test Condition

The IUT and Lower Tester are set up according to the cabled testing setup described in [Section 4.6](#) and common Test Case Conditions defined in [Section 4.2](#) apply.

- Expected Outcome

Pass Verdict

For each frequency tested, the mean of amplitudes measured for each antenna index 'i' from [Table 4.18](#) follows the equation:

$$\text{mean}_{\text{ANT3}} < \text{mean}_{\text{ANT2}} < \text{mean}_{\text{ANT0}} < \text{mean}_{\text{ANT1}}$$

Should there be no valid samples in the non-reference antenna 1, due to saturation, then the pass verdict shall be:

$$\text{mean}_{\text{ANT3}} < \text{mean}_{\text{ANT2}} < \text{mean}_{\text{ANT0}}$$

For each frequency tested, the IUT reports at least 10,000 valid IQ sample pairs per antenna, except for antenna index 1, to the Upper Tester.

The presence of invalid IQ samples does not constitute a failure.

Test Case	PHY
4.5.40.1 RF-PHY/RCV/IQDR/BV-11-C [IQ Samples Dynamic Range, AoA Receiver at 1 Ms/s with 2 μ s Slot]	1 Ms/s
4.5.40.2 RF-PHY/RCV/IQDR/BV-12-C [IQ Samples Dynamic Range, AoA Receiver at 2 Ms/s with 2 μ s Slot]	2 Ms/s

Table 4.19: IQ Samples Dynamic Range, AoA Receiver Test Cases

4.6 Test Setups Examples

This section describes examples of cabled test setups that can be built to run the tests between two Bluetooth devices or between one Bluetooth device and one test equipment.

4.6.1 Test Equipment Setup for AoD Receiver

This setup is used to test IQ samples coherency on an IUT that is an AoD Receiver.

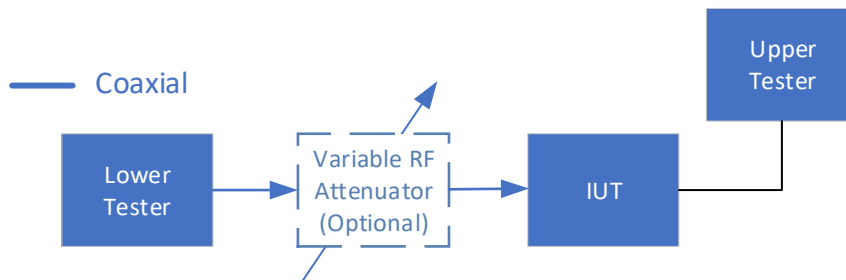


Figure 4.21: Test Equipment Setup for AoD Receiver

4.6.2 Test Equipment Setup for AoA Receiver or AoD Transmitter

This setup is used to test IQ samples coherency on an IUT that is an AoD Transmitter or an AoA Receiver.

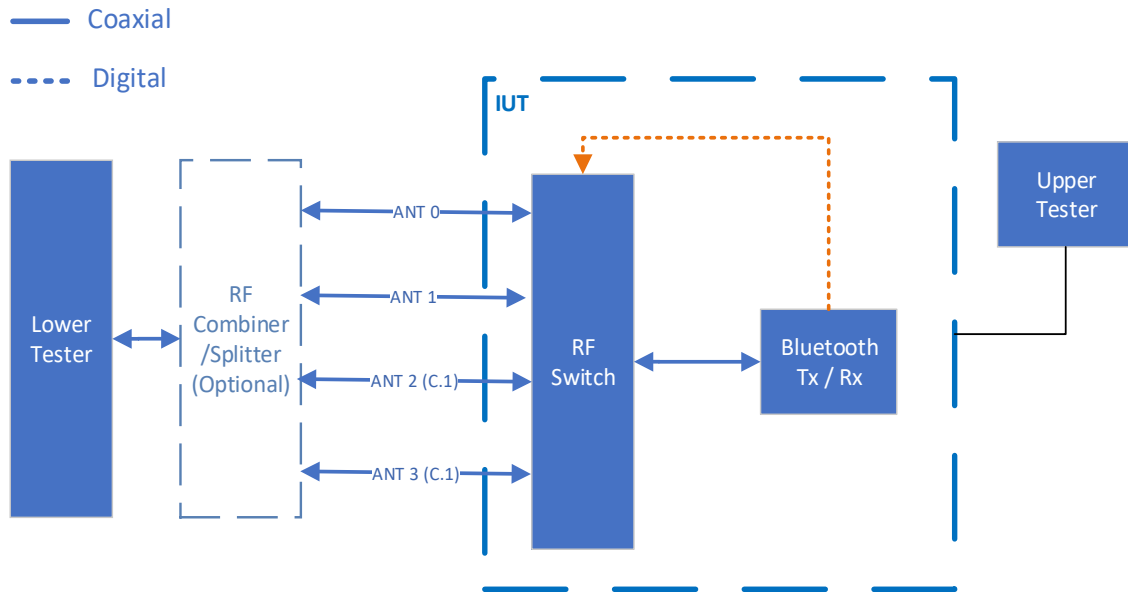


Figure 4.22: Test Equipment Setup for AoA Receiver or AoD Transmitter (C.1 – Mandatory to support if declared, otherwise Excluded)

The IUT is required to provide between 2 to 4 antenna input/output ports, matching the maximum number of antenna supported (TSPX_number_of_antennae) declared in the IXIT [10]. The antenna ports are marked as 0, 1, 2, and 3, as shown in Figure 4.22. If the IUT only supports external antenna switching, an IUT-controlled RF switch component is used.

5 Test Case Mapping

The Test Case Mapping Table (TCMT) maps test cases to specific capabilities in the ICS. Profiles, protocols and services may define multiple roles, and it is possible that a product may implement more than one role. The product shall be tested in all roles for which support is declared in the ICS document. For products which support more than one role, a separate TCMT shall be filled out for each role, and separate tests shall be conducted for each role.

The columns for the TCMT are defined as follows:

Item: contains an y/x reference, where y corresponds to the table number and x corresponds to the feature number as defined in the ICS Proforma for RF PHY [3]. If the item is defined with Protocol, Profile or Service abbreviation before y/x, the table and feature number referenced are defined in the abbreviated ICS proforma document.

Feature: recommended to be the primary feature defined in the ICS being tested or may be the test case name.

Test Case(s): the applicable test case identifiers required for Bluetooth Qualification if the corresponding y/x references defined in the Item column are supported.

For purpose and structure of the ICS/IXIT proforma and instructions for completing the ICS/IXIT proforma refer to the Bluetooth ICS and IXIT proforma document.

Item	Feature	Test Case(s)
RF-PHY 1/1 OR RF-PHY 1/3	Transmitter functionality	RF-PHY/TRM/BV-01-C RF-PHY/TRM/BV-03-C RF-PHY/TRM/BV-05-C RF-PHY/TRM/BV-06-C
(RF-PHY 1/1 OR RF- PHY 1/3) AND RF- PHY 1/8	Transmitter functionality, Transmitting Constant Tone Extensions	RF-PHY/TRM-BV-15-C RF-PHY/TRM-BV-16-C
RF-PHY 1/2 OR RF-PHY 1/3	Receiver functionality	RF-PHY/RCV/BV-01-C RF-PHY/RCV/BV-03-C RF-PHY/RCV/BV-04-C RF-PHY/RCV/BV-05-C RF-PHY/RCV/BV-06-C RF-PHY/RCV/BV-07-C

Item	Feature	Test Case(s)
RF-PHY 1/4	Transceiver functionality for 2 Ms/s PHY	RF-PHY/RCV/BV-08-C RF-PHY/RCV/BV-09-C RF-PHY/RCV/BV-10-C RF-PHY/RCV/BV-11-C RF-PHY/RCV/BV-12-C RF-PHY/RCV/BV-13-C RF-PHY/TRM/BV-08-C RF-PHY/TRM/BV-10-C RF-PHY/TRM/BV-12-C
RF-PHY 1/4 AND RF-PHY 1/8	Transceiver functionality for 2 Ms/s PHY, Transmitting Constant Tone Extensions	RF-PHY/TRM/BV-17-C
RF-PHY 1/4 AND RF-PHY 1/5	Transmitter functionality for 2 Ms/s PHY with stable modulation index	RF-PHY/TRM/BV-11-C
RF-PHY 1/4 AND RF-PHY 1/6	Receiver functionality for 2 Ms/s PHY with stable modulation index	RF-PHY/RCV/BV-20-C RF-PHY/RCV/BV-21-C RF-PHY/RCV/BV-22-C RF-PHY/RCV/BV-23-C RF-PHY/RCV/BV-24-C RF-PHY/RCV/BV-25-C
RF-PHY 1/5	Stable Modulation Index for 1 Ms/s Transmitter	RF-PHY/TRM/BV-09-C
RF-PHY 1/6	Stable Modulation Index for 1 Ms/s Receiver	RF-PHY/RCV/BV-14-C RF-PHY/RCV/BV-15-C RF-PHY/RCV/BV-16-C RF-PHY/RCV/BV-17-C RF-PHY/RCV/BV-18-C RF-PHY/RCV/BV-19-C
(RF-PHY 1/2 OR RF-PHY 1/3) AND RF-PHY 1/7	LE Coded Receiver Functionality	RF-PHY/RCV/BV-26-C RF-PHY/RCV/BV-27-C RF-PHY/RCV/BV-28-C RF-PHY/RCV/BV-29-C RF-PHY/RCV/BV-30-C RF-PHY/RCV/BV-31-C

Item	Feature	Test Case(s)
(RF-PHY 1/1 OR RF-PHY 1/3) AND RF-PHY 1/7	LE Coded Transmitter Functionality	RF-PHY/TRM/BV-13-C RF-PHY/TRM/BV-14-C
RF-PHY 1/6 AND RF-PHY 1/7	LE Coded Receiver Functionality, Stable Modulation Index	RF-PHY/RCV/BV-32-C RF-PHY/RCV/BV-33-C RF-PHY/RCV/BV-34-C RF-PHY/RCV/BV-35-C RF-PHY/RCV/BV-36-C RF-PHY/RCV/BV-37-C
RF-PHY 1/11	2 μ s Antenna Sampling During Constant Tone Extension Reception (AoD)	RF-PHY/RCV/IQC/BV-01-C RF-PHY/RCV/IQC/BV-03-C RF-PHY/RCV/IQDR/BV-07-C RF-PHY/RCV/IQDR/BV-09-C
RF-PHY 1/13	1 μ s Antenna Sampling During Constant Tone Extension Reception (AoD)	RF-PHY/RCV/IQC/BV-02-C RF-PHY/RCV/IQC/BV-04-C RF-PHY/RCV/IQDR/BV-08-C RF-PHY/RCV/IQDR/BV-10-C
RF-PHY 1/12	2 μ s Antenna Switching and Sampling During Constant Tone Extension Reception (AoA)	RF-PHY/RCV/IQC/BV-06-C RF-PHY/RCV/IQDR/BV-12-C
RF-PHY 1/14	1 μ s Antenna Switching and Sampling During Constant Tone Extension Reception (AoA)	RF-PHY/RCV/IQC/BV-05-C RF-PHY/RCV/IQDR/BV-11-C
RF-PHY 1/9	2 μ s Antenna Switching During Constant Tone Extension Transmission (AoD)	RF-PHY/TRM/PS/BV-01-C RF-PHY/TRM/PS/BV-03-C RF-PHY/TRM/ASI/BV-05-C RF-PHY/TRM/ASI/BV-07-C
RF-PHY 1/10	1 μ s Antenna Switching During Constant Tone Extension Transmission (AoD)	RF-PHY/TRM/PS/BV-02-C RF-PHY/TRM/PS/BV-04-C RF-PHY/TRM/ASI/BV-06-C RF-PHY/TRM/ASI/BV-08-C

Table 5.1: Test Case Mapping

6 Appendix

6.1 Reference Signal Definition

The Bluetooth low energy reference signal, either as wanted or an interfering signal, shall have the following characteristics defined in [6] Chapter 4.6.

Payload content of the wanted signal shall be a PRBS9 sequence and shall be identical for all transmitted packets.

In test cases where an interfering signal is used, the interferer shall be continuously modulated with PRBS15 data (i.e. no packet structures or pauses in the signal). The interfering signal shall have settled at least 1ms prior to the activation of the wanted signal.

The tester used for the qualification tests shall have the ramp up characteristics shown in Figure 6.1.

- t_{rampup} is the time from when the tester output is 40 dB below the final output power (x dBm) to the time when the output power has reached a level within $\pm 3\text{dB}$ of the final output power.
- t_{settling} is the time from when the tester output is 40 dB below the final output power (x dBm) to the time when the output power has reached a level within $\pm 1\text{dB}$ of the final output power.
- t_{p0} is the time at which the first preamble bit begins.

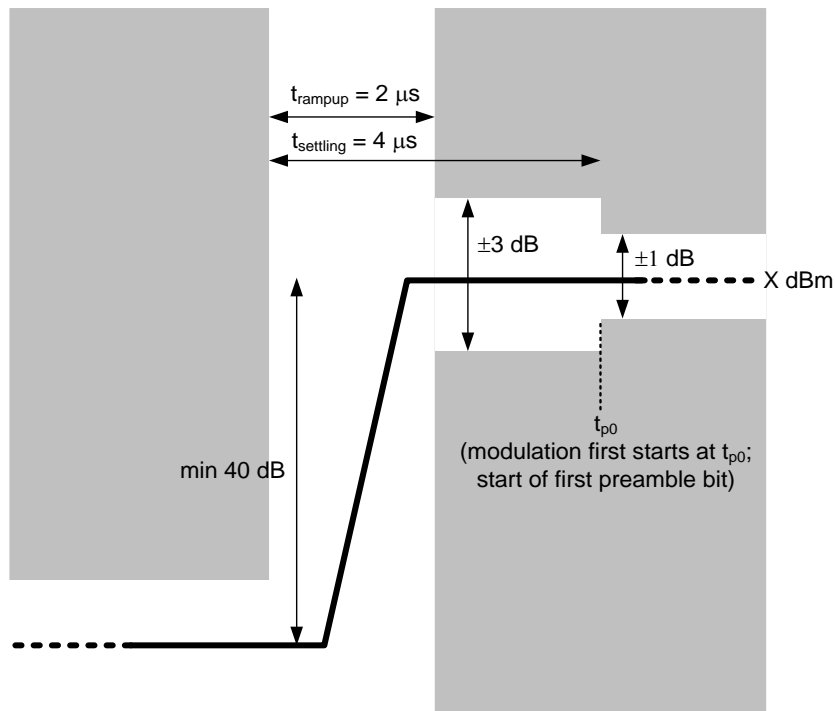


Figure 6.1: Tester ramp-up characteristics requirement, modulation first starts at t_{p0}

6.2 Frequencies for Testing

6.2.1 Operating Frequency Band

Bluetooth low energy operates in the global ISM frequency band located at 2400 MHz to 2483.5 MHz. The Bluetooth low energy system uses center frequencies $2402 + n \cdot 2$ MHz, where $n = 0, 1, 2, \dots, 39$. The total number of communication frequencies is 40.

The Bluetooth low energy RF PHY test suite uses the direct test mode in all transmit and receive test cases [4]. In direct test mode, hopping is disabled and the IUT's transmit- and receive frequencies are set according to [Table 6.1](#) and [Table 6.2](#).

Note that the test frequencies differ depending on the profile role(s) implemented. For devices or products supporting both connectible and non-connectible roles (e.g. peripheral and broadcaster roles), the frequencies for testing shall be as for the connectible role(s) supported.

6.2.2 Frequencies for Testing: Peripheral and Central Devices

Test case(s)	Lowest		Middle		Highest	
	IUT fTX	IUT fRX	IUT fTX	IUT fRX	IUT fTX	IUT fRX
RF-PHY/TRM/BV-01-C	2402 MHz	2402 MHz	2440 MHz	2440 MHz	2480 MHz	2480 MHz
RF-PHY/TRM/BV-05-C	(n=0)	(n=0)	(n=19)	(n=19)	(n=39)	(n=39)
RF-PHY/TRM/BV-06-C						
RF-PHY/TRM/BV-09-C						
RF-PHY/TRM/BV-10-C						
RF-PHY/TRM/BV-11-C						
RF-PHY/TRM/BV-12-C						
RF-PHY/TRM/BV-13-C						
RF-PHY/TRM/BV-14-C						
RF-PHY/RCV/BV-01-C						
RF-PHY/RCV/BV-05-C						
RF-PHY/RCV/BV-06-C						
RF-PHY/RCV/BV-08-C						
RF-PHY/RCV/BV-11-C						
RF-PHY/RCV/BV-12-C						
RF-PHY/RCV/BV-14-C						
RF-PHY/RCV/BV-17-C						
RF-PHY/RCV/BV-18-C						
RF-PHY/RCV/BV-20-C						
RF-PHY/RCV/BV-23-C						
RF-PHY/RCV/BV-24-C						
RF-PHY/RCV/BV-26-C						
RF-PHY/RCV/BV-27-C						



Test case(s)	Lowest		Middle		Highest	
	IUT fTX	IUT fRX	IUT fTX	IUT fRX	IUT fTX	IUT fRX
RF-PHY/RCV/BV-32-C RF-PHY/RCV/BV-33-C						
RF-PHY/TRM/BV-03-C RF-PHY/TRM/BV-08-C RF-PHY/RCV/BV-03-C RF-PHY/RCV/BV-09-C RF-PHY/RCV/BV-15-C RF-PHY/RCV/BV-21-C RF-PHY/RCV/BV-28-C RF-PHY/RCV/BV-29-C RF-PHY/RCV/BV-34-C RF-PHY/RCV/BV-35-C	2406 MHz (n=2)	2406 MHz (n=2)	2440 MHz (n=19)	2440 MHz (n=19)	2476 MHz (n=37)	2476 MHz (n=37)
RF-PHY/RCV/BV-07-C RF-PHY/RCV/BV-13-C RF-PHY/RCV/BV-19-C RF-PHY/RCV/BV-25-C RF-PHY/RCV/BV-30-C RF-PHY/RCV/BV-31-C RF-PHY/RCV/BV-36-C RF-PHY/RCV/BV-37-C			-	2440 MHz (n=19)		
RF-PHY/RCV/BV-04-C RF-PHY/RCV/BV-10-C RF-PHY/RCV/BV-16-C RF-PHY/RCV/BV-22-C			-	2426 MHz (n=12)		

Table 6.1: Test frequencies for peripheral and central devices, transmit and receive test cases

6.2.3 Frequencies for Testing: Broadcaster and Observer Devices

Test case(s)	Lowest		Middle		Highest	
	IUT fTX	IUT fRX	IUT fTX	IUT fRX	IUT fTX	IUT fRX
RF-PHY/TRM/BV-01-C	2402 MHz	2402 MHz	2426 MHz	2426 MHz	2480 MHz	2480 MHz
RF-PHY/TRM/BV-03-C	(n=0)	(n=0)	(n=12)	(n=12)	(n=39)	(n=39)
RF-PHY/TRM/BV-05-C						
RF-PHY/TRM/BV-06-C						
RF-PHY/TRM/BV-08-C						
RF-PHY/TRM/BV-09-C						
RF-PHY/TRM/BV-10-C						
RF-PHY/TRM/BV-11-C						
RF-PHY/TRM/BV-12-C						
RF-PHY/TRM/BV-13-C						
RF-PHY/TRM/BV-14-C						
RF-PHY/RCV/BV-01-C						
RF-PHY/RCV/BV-03-C						
RF-PHY/RCV/BV-05-C						
RF-PHY/RCV/BV-06-C						
RF-PHY/RCV/BV-08-C						
RF-PHY/RCV/BV-09-C						
RF-PHY/RCV/BV-11-C						
RF-PHY/RCV/BV-12-C						
RF-PHY/RCV/BV-14-C						
RF-PHY/RCV/BV-15-C						
RF-PHY/RCV/BV-17-C						
RF-PHY/RCV/BV-18-C						
RF-PHY/RCV/BV-20-C						
RF-PHY/RCV/BV-21-C						
RF-PHY/RCV/BV-23-C						
RF-PHY/RCV/BV-24-C						
RF-PHY/RCV/BV-26-C						
RF-PHY/RCV/BV-27-C						
RF-PHY/RCV/BV-28-C						
RF-PHY/RCV/BV-29-C						
RF-PHY/RCV/BV-32-C						
RF-PHY/RCV/BV-33-C						

Test case(s)	Lowest		Middle		Highest	
	IUT fTX	IUT fRX	IUT fTX	IUT fRX	IUT fTX	IUT fRX
RF-PHY/RCV/BV-34-C RF-PHY/RCV/BV-35-C						
RF-PHY/RCV/BV-04-C RF-PHY/RCV/BV-07-C RF-PHY/RCV/BV-10-C RF-PHY/RCV/BV-13-C RF-PHY/RCV/BV-16-C RF-PHY/RCV/BV-19-C RF-PHY/RCV/BV-22-C RF-PHY/RCV/BV-25-C RF-PHY/RCV/BV-30-C RF-PHY/RCV/BV-31-C RF-PHY/RCV/BV-36-C RF-PHY/RCV/BV-37-C			-	2426 MHz (n=12)		
RF-PHY/RCV/IQC/BV-01-C RF-PHY/RCV/IQC/BV-02-C RF-PHY/RCV/IQC/BV-03-C RF-PHY/RCV/IQC/BV-04-C RF-PHY/RCV/IQC/BV-05-C RF-PHY/RCV/IQC/BV-06-C RF-PHY/RCV/IQDR/BV-07-C RF-PHY/RCV/IQDR/BV-08-C RF-PHY/RCV/IQDR/BV-09-C RF-PHY/RCV/IQDR/BV-10-C RF-PHY/RCV/IQDR/BV-11-C RF-PHY/RCV/IQDR/BV-12-C RF-PHY/TRM/PS/BV-01-C RF-PHY/TRM/PS/BV-02-C RF-PHY/TRM/PS/BV-03-C RF-PHY/TRM/PS/BV-04-C	2402 MHz (n=0)	2402 MHz (n=0)	2440 MHz (n=19)	2440 MHz (n=19)	2480 MHz (n=39)	2480 MHz (n=39)



Test case(s)	Lowest		Middle		Highest	
	IUT fTX	IUT fRX	IUT fTX	IUT fRX	IUT fTX	IUT fRX
RF-PHY/TRM/ASI/BV-05-C						
RF-PHY/TRM/ASI/BV-06-C						
RF-PHY/TRM/ASI/BV-07-C						
RF-PHY/TRM/ASI/BV-08-C						

Table 6.2: Test frequencies for broadcaster and observer devices (non-connectible), all transmit and receive test cases

6.3 Normal Operating Conditions (NOC)

6.3.1 Normal Temperature and Air Humidity

The normal operating temperature shall be declared by the equipment manufacturer as an IXIT value. The NOC test temperature shall be within $\pm 10^{\circ}\text{C}$ of this value.

Operating air humidity range shall be declared by the product manufacturer as maximum and minimum values (IXIT). The air humidity level for the NOC tests shall be within the declared range.

The temperature and air humidity values during the test shall be recorded in the test documentation.

6.3.2 Nominal Supply Voltage

The IUT supply voltage under normal operating conditions shall be the nominal supply voltage as declared by the IUT manufacturer.

The nominal supply voltage shall be recorded in the test documentation.

6.4 Packet Error Rate / Bit Error Rate Measurements

The Packet Error Rate (PER) measurement is used in all measurements testing receiver characteristics in the Bluetooth low energy RF PHY test suite. PER tests are based on the direct test mode described in [4].

6.4.1 PER Test Definition

PER tests are based on counting the number of packets received by the IUT out of a series of consecutive LE test packets transmitted by the tester. The test is performed with frequency hopping disabled.

The packet error rate is defined as follows:

$$PER = \left(1 - \frac{\text{Number of packets received by the EUT passing CRC}}{\text{Total number of packets transmitted by the tester}} \right) \cdot 100\%$$

The tester transmits LE test packets with PRBS9 payload as defined in [4], Section 4 to the IUT. Upon request from the tester to the IUT, the IUT shall report the number of LE test packets that has been correctly received (i.e. passing CRC) since last request. Refer to [4] for detailed description of the direct test mode.



The sensitivity level based on BER measurements is defined as the input power level at which a BER of value specified in [Table 6.3](#) is achieved measured with a reference signal as described in [Section 6.1](#), and packet with PRBS9 payload as described in [\[4\]](#), [Section 4](#).

Maximum Supported Payload Length in Receiver (bytes)	BER (%)
37	0.1
≥38 and ≤63	0.064
≥64 and ≤127	0.034
≥128 and ≤255	0.017

Table 6.3: Sensitivity BER level by maximum payload length in receiver

The PER corresponding to the acceptable BER limit shall be calculated according to the formula below:

$$\text{PER} = (1 - X [(\text{MAX_RX_LENGTH} * 8) + 72]) \times 100\%$$

- $X = 1 - \text{BER}$,
- i.e. $X=0.9990$ if $\text{MAX_RX_LENGTH}=37$,
- $X=0.99936$ if $38 \leq \text{MAX_RX_LENGTH} \leq 63$,
- $X=0.99966$ if $64 \leq \text{MAX_RX_LENGTH} \leq 127$,
- $X=0.99983$ if $128 \leq \text{MAX_RX_LENGTH} \leq 255$.
- MAX_RX_LENGTH is the maximum supported payload length in IUT's receiver and it shall be declared in RF-PHY IXIT proforma in range of 37 ~ 255.
- 72 in the formula is total length of synchronization word, PDU header, PDU length & CRC parts in LE test packet in bit unit.

6.4.2 BER to PER Mapping

This PER requirement defined in [Section 6.4.1](#) equates to the corresponding BER value under the following assumptions:

- bit errors are randomly distributed with a rectangular error probability density function
- bit errors are not correlated

Furthermore, the following reasoning is applied (using an example of BER to PER mapping based on a BER value of 0.1% and MAX_RX_LENGTH of 37 bytes):

- The probability of a particular bit being in error at a BER of 0.1% is 0.001
- It follows that the probability of a bit being OK under the same condition is 0.999

- Examining the impact of a bit error in the LE test packet with a 37-byte payload length:

Preamble (8 bit)	Packet can be recovered ⁵
Sync word (32 bit)	Error; Packet is lost
Packet type field (16 bit)	Error; Packet is lost
Payload (296 bit)	Error; Packet is lost
CRC (24 bit)	Error; Packet is lost

- The number of significant bits in a 37-byte payload LE test packet is thus 368 bits (out of a total of 376 bits).
- The probability of a 368 bit sequence containing no bit errors is $0.999368 = 0.692$
- Resulting PER requirement is then $(1 - 0.692) \cdot 100\% = 30.8\%$

The sensitivity BER by maximum payload length in the receiver corresponds to the PER requirements listed in [Table 6.4](#) below:

Maximum Supported Payload Length in Receiver (bytes)	PER
37	30.8%
38	21.4%
39	21.8%
40	22.2%
41	22.6%
42	23.0%
43	23.4%
44	23.8%
45	24.2%
46	24.5%
47	24.9%
48	25.3%
49	25.7%
50	26.1%

⁵ The effect of errors in the preamble is implementation dependent. In general, a bit error in the preamble does not automatically imply that the packet is lost. It is therefore assumed that an error in the preamble is "allowed" and that the packet is recoverable.

Maximum Supported Payload Length in Receiver (bytes)	PER
51	26.5%
52	26.8%
53	27.2%
54	27.6%
55	27.9%
56	28.3%
57	28.7%
58	29.0%
59	29.4%
60	29.8%
61	30.1%
62	30.5%
63	30.8%
64	18.0%
65	18.2%
66	18.5%
67	18.7%
68	18.9%
69	19.1%
70	19.3%
71	19.6%
72	19.8%
73	20.0%
74	20.2%
75	20.4%
76	20.6%

Maximum Supported Payload Length in Receiver (bytes)	PER
77	20.9%
78	21.1%
79	21.3%
80	21.5%
81	21.7%
82	21.9%
83	22.1%
84	22.4%
85	22.6%
86	22.8%
87	23.0%
88	23.2%
89	23.4%
90	23.6%
91	23.8%
92	24.0%
93	24.2%
94	24.4%
95	24.6%
96	24.8%
97	25.1%
98	25.3%
99	25.5%
100	25.7%
101	25.9%
102	26.1%



Maximum Supported Payload Length in Receiver (bytes)	PER
103	26.3%
104	26.5%
105	26.7%
106	26.9%
107	27.1%
108	27.3%
109	27.5%
110	27.7%
111	27.9%
112	28.0%
113	28.2%
114	28.4%
115	28.6%
116	28.8%
117	29.0%
118	29.2%
119	29.4%
120	29.6%
121	29.8%
122	30.0%
123	30.2%
124	30.4%
125	30.5%
126	30.7%
127	30.9%
128	17.0%

Maximum Supported Payload Length in Receiver (bytes)	PER
129	17.1%
130	17.2%
131	17.3%
132	17.5%
133	17.6%
134	17.7%
135	17.8%
136	17.9%
137	18.0%
138	18.1%
139	18.2%
140	18.3%
141	18.5%
142	18.6%
143	18.7%
144	18.8%
145	18.9%
146	19.0%
147	19.1%
148	19.2%
149	19.3%
150	19.4%
151	19.6%
152	19.7%
153	19.8%
154	19.9%



Maximum Supported Payload Length in Receiver (bytes)	PER
155	20.0%
156	20.1%
157	20.2%
158	20.3%
159	20.4%
160	20.5%
161	20.6%
162	20.8%
163	20.9%
164	21.0%
165	21.1%
166	21.2%
167	21.3%
168	21.4%
169	21.5%
170	21.6%
171	21.7%
172	21.8%
173	21.9%
174	22.0%
175	22.1%
176	22.2%
177	22.4%
178	22.5%
179	22.6%
180	22.7%

Maximum Supported Payload Length in Receiver (bytes)	PER
181	22.8%
182	22.9%
183	23.0%
184	23.1%
185	23.2%
186	23.3%
187	23.4%
188	23.5%
189	23.6%
190	23.7%
191	23.8%
192	23.9%
193	24.0%
194	24.1%
195	24.2%
196	24.3%
197	24.4%
198	24.5%
199	24.6%
200	24.7%
201	24.8%
202	24.9%
203	25.0%
204	25.2%
205	25.3%
206	25.4%

Maximum Supported Payload Length in Receiver (bytes)	PER
207	25.5%
208	25.6%
209	25.7%
210	25.8%
211	25.9%
212	26.0%
213	26.1%
214	26.2%
215	26.3%
216	26.4%
217	26.5%
218	26.6%
219	26.7%
220	26.8%
221	26.9%
222	27.0%
223	27.1%
224	27.2%
225	27.3%
226	27.4%
227	27.5%
228	27.6%
229	27.7%
230	27.8%
231	27.9%
232	27.9%



Maximum Supported Payload Length in Receiver (bytes)	PER
233	28.0%
234	28.1%
235	28.2%
236	28.3%
237	28.4%
238	28.5%
239	28.6%
240	28.7%
241	28.8%
242	28.9%
243	29.0%
244	29.1%
245	29.2%
246	29.3%
247	29.4%
248	29.5%
249	29.6%
250	29.7%
251	29.8%
252	29.9%
253	30.0%
254	30.1%
255	30.2%

Table 6.4: PER level by maximum payload length in receiver

6.5 Definition of the Position of Bit p0

Bit p0 is defined as the first bit in the preamble sequence. The start of p0 is defined to occur at the point in time 56 bit periods before the instant at which the modulated carrier passes through the nominal channel frequency immediately prior to the deviation corresponding to the first bit of the payload field.

The start of bit p0 is calculated using averaging based on the position of all the zero crossings in the packet:

For the m zero crossings in the packet, the i 'th zero crossing time instant is $t(i)$ in μs ; this is the start of bit $p(i)$.

The start of bit p0 is then calculated as:

$$t_0 = \frac{1}{m} \sum_{i=1}^m (t(i) - p(i)) \quad [\mu\text{s}]$$

6.6 Measurement Uncertainty

Table 6.5 contains the measurement accuracy requirements for the test cases described in this document. The test equipment used for the tests must have measurement accuracy within the listed limits. The verdict decision limits for each test case take the measurement uncertainty listed in Table 6.5 into account. All figures in the table reflect a 95% confidence level.

Type of measurement	Measurement accuracy requirement
Conducted measurements: Absolute RF power (wanted channel)	± 1.2 dB
Absolute RF power (unwanted emissions in the 2400 – 2483.5 MHz band)	± 3 dB
Absolute RF power (unwanted emissions outside the 2400 – 2483.5 MHz band)	± 3 dB ⁶
Relative RF power: Relative RF power (wanted channel)	± 1 dB
Radiated measurements: Absolute RF power (wanted channel)	± 6 dB
Radiated emissions (for unwanted emissions)	± 6 dB
Absolute frequency: Absolute frequency (RF frequencies)	± 5 kHz
Absolute frequency (Frequency deviation of modulated signal)	± 4 kHz

⁶ For frequencies above 4GHz, a measurement accuracy requirement of ± 4 dB applies

Type of measurement	Measurement accuracy requirement
Relative frequency: Relative frequency (Frequency drift of carrier during modulation)	± 1 kHz

Table 6.5: Measurement accuracy requirements

6.7 Packet Lengths

Note: Symbols with names beginning “PL_” are only defined and used within this section.

For each symbol in the first column of [Table 6.6](#), the value of the symbol shall be the greater of the values of the symbols in the other two columns.

MAX_TX_LENGTH	PL_ADV_L	PL_DTX_1M
MAX_TX_LENGTH_2M	PL_ADV_X	PL_DTX_2M
MAX_TX_LENGTH_CODED_S2	PL_ADV_X	PL_DTX_C2
MAX_TX_LENGTH_CODED_S8	PL_ADV_X	PL_DTX_C8
MAX_RX_LENGTH	PL_SCN_L	PL_DRX_1M
MAX_RX_LENGTH_2M	PL_SCN_X	PL_DRX_2M
MAX_RX_LENGTH_CODED_S2	PL_SCN_X	PL_DRX_C2
MAX_RX_LENGTH_CODED_S8	PL_SCN_X	PL_DRX_C8

Table 6.6: Overall Inputs for Packet Length Symbols

If the Link Layer of the IUT supports the Advertising Extension feature, then:

- PL_ADV_L and PL_ADV_X shall equal TSPX_AdvOctets_Max.
- PL_SCN_L and PL_SCN_X shall equal 255.

Otherwise:

- PL_ADV_L and PL_SCN_L shall equal 37.
- PL_ADV_X and PL_SCN_X shall equal 31.

If the Link Layer of the IUT supports the Data Length Extension feature, then for each symbol in the first column of [Table 6.7](#), the value of the symbol shall be the lesser of the values of the expressions in the other two columns (“[X]” means the greatest integer less than or equal to X).

PL_DTX_1M	TSPX_TxOctets_Max+4	$\lfloor \text{TSPX_TxTime_Max} \div 8 - 10 \rfloor$
PL_DTX_2M	TSPX_TxOctets_Max+4	$\lfloor \text{TSPX_TxTime_Max} \div 4 - 11 \rfloor$
PL_DTX_C2	TSPX_TxOctets_Max+4	$\lfloor \text{TSPX_TxTime_Max} \div 16 - 28 \rfloor$
PL_DTX_C8	TSPX_TxOctets_Max+4	$\lfloor \text{TSPX_TxTime_Max} \div 64 - 11 \rfloor$
PL_DRX_1M	TSPX_RxOctets_Max+4	$\lfloor \text{TSPX_RxTime_Max} \div 8 - 10 \rfloor$
PL_DRX_2M	TSPX_RxOctets_Max+4	$\lfloor \text{TSPX_RxTime_Max} \div 4 - 11 \rfloor$
PL_DRX_C2	TSPX_RxOctets_Max+4	$\lfloor \text{TSPX_RxTime_Max} \div 16 - 28 \rfloor$
PL_DRX_C8	TSPX_RxOctets_Max+4	$\lfloor \text{TSPX_RxTime_Max} \div 64 - 11 \rfloor$

Table 6.7: Maximum Lengths When Data Length Extension is Supported

Otherwise, the values of all the symbols in the first column of [Table 6.7](#) shall be 31.

Note: For each symbol in the first column of [Table 6.8](#), the reference for that symbol in [\[5\]](#) is given in the second column. The third and fourth columns give the minimum and maximum permitted values for the symbol.

TSPX_AdvOctets_Max	LL:P4:19 on the LL tab	37	255
TSPX_RxOctets_Max	LL:P4:17 on the LL tab	27	251
TSPX_RxTime_Max	LL:P4:18 on the LL tab	328	17040
TSPX_TxOctets_Max	LL:P4:15 on the LL tab	27	251
TSPX_TxTime_Max	LL:P4:16 on the LL tab	328	17040

Table 6.8: References

6.8 Number of Valid IQ Sample Pairs

This section and its subsections are informative.

A controller can return IQ sample pairs where either I or Q, or both, are marked as ‘No Valid Sample Available’. These IQ sample pairs shall be discarded as invalid. Invalid IQ sample pairs shall not be used in the magnitude, relative phase, and reference phase deviation calculations.

The number of valid IQ sample pairs required per non-reference antenna for the IQ Samples Coherency tests is chosen as 10,000. The same number of valid IQ sample pairs is chosen for the IQ Dynamic Range tests, to maintain consistency across the tests.



6.8.1 Maximum Number of Packets for IQ Coherency Measurements

The tests require LE packets to be sent with maximum length CTE comprising of 1 μ s or 2 μ s slots. The number of collected IQ sample pairs per packet is either 74 or 37, respectively. The measurements are performed using IQ sample pair groups that must include non-reference antenna transmissions. Using the pre-defined switching pattern (x000, ..., where x is a non-reference antenna), a maximum of 18 sample pairs groups for 1 μ s slots and 8 sample pairs groups for 2 μ s slots that include all required IQ sample measurements are possible from every CTE.

The following tables show the number of IQ sample pairs returned by the IUT for different number of non-reference antenna for 1us and 2us switching slots, respectively.

Number of non-reference antennae	1	2	3
1	18	0	0
2	9	9	0
3	6	6	6

Table 6.9: Number of I/Q samples per antenna element for 1 μ s switching slots

Number of non-reference antennae	1	2	3
1	8	0	0
2	4	4	0
3	2	3	3

Table 6.10: Number of I/Q samples per antenna element for 2 μ s switching slots

Table for the number of packets transmitted required to obtain 10,000 IQ sample pairs per non-reference antenna on the receiver is shown below;

Number of non-reference antennae	1 μ s switching slot	2 μ s switching slot
1	556	1250
2	1112	2500
3	1667	3334

Table 6.11: Number of packets required for 10,000 IQ sample pairs

The [Table 6.11](#) assumes that IUT receives all packets successfully, and all the IQ sample pairs reported are marked valid.

The number of packets transmitted required for the test needs to be increased to allow for both lost packets and invalid IQ sample pairs. A 20% allowance to account for lost packets and invalid IQ sample

pairs is recommended. The IUT reports IQ sample pairs at a rate of TSPX_IQ_Report_Rate. The number of packets transmitted by the tester for the measurement needs to scale by the following factor:

$$\text{ceil} \left[\frac{\text{Number of Transmitted LE Packets per second}}{\text{TSPX_IQ_Report_Rate}} \right]$$

This is the recommended maximum number of packets transmitted by the tester for the coherency tests. For TP/RCV-LE/CA/BV-09-C, updated interference frequency selection formula in step 4 of test procedure and updated adjacent channels in table and Pass Verdict.

7 Revision History and Contributors

Revision History

Revision History	Date	Comments
0.9d4	2009-04-02	Updated references, version submitted to BTI
0.9	2009-04-24	0.9 version approved by the BTI. Modulation characteristics TC aligned with BR/EDR wrt calculating $\Delta f_{1\text{avg}}$ and $\Delta f_{2\text{avg}}$. The 0.9d4 version submitted for review was approved by the BTI as 0.9 on the condition that the adjustments above were implemented.
1.0d1	2009-10-27	First 1.0 draft. Updated Table 7:2 and 7:3 (Errata #3239), fixed broken reference p34. Text modification in Ch 7.5.2; Content of table is informal (TS follow-up to Errata #3161).
1.0d2	2009-10-30	Further updates as a result of Errata #3161 and #3276. NTC/ETC changed to NOC/EOC. Updated with separate test case definitions for NOC and EOC.
1.0d3	2009-11-20	Corrected typo; maximum interferer frequency in RCV-LE/CA/BV-02-C. TC naming conventions aligned with BR/EDR. Terms 'connectable' and 'non-connectable' added for clarification in Sect 7.3. TC's RCV-LE/CA/BV-02-C and RCV-LE/CA/BV-03-C aligned with other TC's wrt test procedure content/description. Normative references update. Editorial review
1.0d4	2009-11-23	Editorial pass; changed alphanumerics to numerics in test procedures; added periods; checked that xrefs are blue. Updated date and doc ID; renamed file to match Doc ID.
1.0d5	2009-11-25	Adjustments to SIG test case numbering practices (e.g TRM-LE/CA/BV-01-1/C to TRM-LE/CA/BV-01-C etc)
1.0d6, 1.0d7	2009-11-30, 09-10-11	Editorial updates
RF-PHY.TS/4.0.0	2009-12-15	Prepare for publication.
4.0.1r0 4.0.1r1	2010-12-01- 2011-02-02	TSE 3408: TRM-LE/CA/BV-03-C , TRM-LE/CA/BV-04-C: updates 5, 6 TSE 3462 Rename test case in Tables 7.2 and 7.3 : TSE 3945: Remove Section 7.2 and refer to ESR05, eventually to be moved to core spec Vol 6, Part D Section 4. See also TSE 4204. TSE 4204: Additional changes for E3696 (see also TSE 3945)
4.0.1	2011-07-18	Prepare for publication.



Revision History	Date	Comments
4.0.2r0	2012-09-06	TSE 4906: Change to test procedure of TRM-LE/CA/BV-03-C added, "AND skip to next frequency if the increased frequency equals to fTX or "fTX - 1MHz" or "fTX + 1MHz".
4.0.2	2012-11-15	Prepare for Publication
4.0.3r1	2013-05-31	TSE 5041: Editorial correction in step 3 of the test procedure for test case RCV-LE/CA/BV-01-C, incorrect cross-reference. TSE 5042: Editorial correction to the cross-reference in Figure 6.7 in RCV-LE/CA/BV-03-C that referenced "Table 6.4" when it should have referenced "6.3". TSE 5043: Editorial correction to the cross-reference in Figure 6.8 in RCV-LE/CA/BV-04-C that referenced "Table 6.5" when it should have referenced "6.4". TSE 5044: Editorial correction in the 3rd paragraph of the pass verdict for test case RCV-LE/CA/BV-04-C.
4.0.3r2,	2013-06-03	BTI Review, comments from Miles.
4.0.3r3	2013-06-04	BTI Review, comments from Dan. Updated Copyright Notice to 2013. Changed Table reference to figure reference in Step 4 of TRM-LE/CA/BV-06-C.
4.0.3r4	2013-06-04	BTI Review, additional comments from Dan TRM-LE/CA/BV-04-C was an incorrect heading level, changed it to the test case heading level which updated the section from 6.3 to 6.3.4.
4.0.3	2013-07-02	Prepare for Publication
4.1.0r01	2013-11-11	Revision to accommodate v 4.1
4.1.0	2013-12-03	Prepare for Publication
4.1.0 – Template Conversion	2014-01-23	Template Conversion into Template_TS_2014r02
4.1.1r00	2014-01-23	TSE 5507: Correctly formatted the TC IDs for TRM-LE/CA/BV-01-C, TRM-LE/CA/BV-02-C, TRM-LE/CA/BV-03-C, TRM-LE/CA/BV-04-C, TRM-LE/CA/BV-05-C, TRM-LE/CA/BV-06-C, TRM-LE/CA/BV-07-C, RCV-LE/CA/BV-01-C, RCV-LE/CA/BV-02-C, RCV-LE/CA/BV-03-C, RCV-LE/CA/BV-04-C, RCV-LE/CA/BV-05-C, RCV-LE/CA/BV-06-C, RCV-LE/CA/BV-07-C.
4.1.2r00	2014-10-21	TSE 5635: Corrected a statement that had lost the superscript, "The probability of a 368 bit sequence containing not bit errors is $0.999^{368} = 0.692$ "

Revision History	Date	Comments
4.1.2r01	2014-11-05	BTI Review, Magnus, Removed Test Suite Structure illustration.
4.2.0r00	2014-11-07	Integrated CRs from RF-PHY TS 4 1 0-Data_Length_Increase_r02.
4.2.0r01	2014-11-24	Updated Test Case numbering convention to match convention in TCRL (added "BV" and dashes).
4.2.0	2014-12-04	Prepare for TCRL 2014-2 publication
4.2.1r00	2015-05-06	<p>TSE 6142: Updated Section 6.6 to be consistent with revised sensitivity levels in Core spec. Revised Pass verdicts accordingly for TP/RCV-LE/CA/BV-01-C, TP/RCV-LE/CA/BV-03-C, TP/RCV-LE/CA/BV-04-C, TP/RCV-LE/CA/BV-05-C, TP/RCV-LE/CA/BV-06-C.</p> <p>TSE 6100: Deleted "EIRP" in TP/TRM-LE/CA/BV-01-C Pass verdict.</p> <p>TSE 6140: Revised References section to remove redundant entries and correct errors. Updated instances of those references throughout the document.</p> <p>TSE 6340: Corrected equation in step 5 of TP/TRM-LE/CA/BV-03-C</p> <p>TSE 6368: Corrected references to other steps in steps 8 and 12 of TP/TRM-LE/CA/BV-03-C</p>
4.2.1r01	2015-05-18	TSE 6413: Revised PER value in Pass verdict of TP/RCV-LE/CA/BV-07-C
4.2.1r02	2015-06-03	Editorial: Universal change from EUT to IUT Removal of redundant Section 6.5 (Test Conditions Summary)
4.2.1	2015-07-14	Prepared for TCRL 2015-1 publication
4.2.2r00	2015-10-09	<p>TSE 6369: Changed interval for frequency drift rate #0 in Figure 4.5 and updated the pass criterion frequency for TP/TRM-LE/CA/BV-06-C.</p> <p>TSE 6622: Removed TP/TRM-LE/CA/BV-02-C, TP/TRM-LE/CA/BV-04-C, TP/TRM-LE/CA/BV-07-C, and TP/RCV-LE/CA/BV-02-C.</p> <p>TSE 6682: Revised initial conditions for TP/TRM-LE/CA/BV-01-C, TP/TRM-LE/CA/BV-03-C, TP/TRM-LE/CA/BV-05-C, TP/TRM-LE/CA/BV-06-C, TP/RCV-LE/CA/BV-01-C, TP/RCV-LE/CA/BV-03-C, TP/RCV-LE/CA/BV-04-C, TP/RCV-LE/CA/BV-05-C, TP/RCV-LE/CA/BV-06-C, and TP/RCV-LE/CA/BV-07-C. Also added Section 6.8 Packet Lengths.</p>

Revision History	Date	Comments
4.2.2r01	2015-10-27	Reviewed by Dave Richter. Editorial changes resulting from TSE 6622: Removed Section 6.4 (EOC); removed other references to extreme conditions throughout; removed references to normal conditions throughout where they became redundant with the removal of extreme operating conditions.
4.2.2r02	2015-11-03	Reviewed by Magnus Sommansson. Reinstated "Test Condition" test sections with instructions to perform tests at normal operating conditions.
4.2.2r03	2015-11-18	Integrated changes for Core Specification Addendum 5 (CSA5): Added references and updated pass verdict for TP/TRM-LE/CA/BV-01-C [Output power].
4.2.2	2015-12-22	Prepared for TCRL 2015-2 publication
4.2.3r00	2016-02-11	TSE 6818: Added Section 4.4 Common Test Case Conditions. The following changes applied to all test cases: First initial condition moved to Section 4.4. Added new test condition with cross-reference to Section 4.4. Deleted test condition moved to Section 4.4.
4.2.3r01	2016-03-02	TSE 6917: Relaxation measurement criteria changed in TP/RVC-LE/CA/BV-03-C from "does not apply" exceptions to "does apply" admissions.
4.2.3r02	2016-04-07	TSE 6395: Updated Initial Condition of test case TP/RVC-LE/CA/BV-01-C. Corrected "(2) to 3)" to "(2) to 4)." Changed modulation frequency to 1250 Hz. Second to last sentence reworded slightly. MSC updated. Changed f_{mod} to "1250 Hz" and T/4 to "200 μ s."
4.2.3	2016-07-13	Prepared for TCRL 2016-1 publication
5.0.0r00	2016-07-07	Integrated changes for Core Specification 5.0 release: 2MBPS_Test_Cases_CRr12: Global edit. Added 5 new sections for test cases TRM-LE/CA/BV-07-C – 11-C. Added 18 new sections for test cases TP/RVC-LE/CA/BV-08-C – 25-C. BLR_Test_Cases_CRr12: Global edit. Added 2 new sections for test cases TP/TRM-LE/CA/BV-12-C & 13-C. Added 12 new sections for test cases TP/RVC-LE/CA/BV-26-C – 37 C.
5.0.0r01	2016-06-28	Issue 7189: Updated test case TP/TRM-LE/CA/BV-12-C: Updated Steps 4, 8, and 9. Deleted Steps 8–12. Updated Pass Verdict. Issue 7286: Entire "Packet Lengths" section rewritten.

Revision History	Date	Comments
5.0.0r02	2016-09-02	Issue 7553: Added sum symbol (Σ) to step 6 in test case TP/TRM-LE/CA/BV-07-C. Global edits: Removed/replaced "must" in Pass verdict. Updated legacy test text: Changed "...at 1 Ms/s" to "...uncoded data at 1 Ms/s." Deleted condition from legacy tests. Reference instead Section 4.4, Common Test Case Conditions. Updated Test Condition to reference Section 4.4. Step numbering corrected in test case TP/RVCV-LE/CA/BV-09-C and TP/RVCV-LE/CA/BV-11-C. Replaced all occurrences of "at NOC" with "uncoded data at 1 Ms/s."
5.0.0r03	2016-09-20	Issue 7643: Updated description of interference signal in Test Procedure for test cases TP/RVCV-LE/CA/BV-03-C, 05-C, 09-C, 11-C, 28-C, and 29-C.
5.0.0r04	2016-10-03	Issue 7733: Added missing space between sentences in Test Purposes > Conformance section. Updated test case TP/RVCV-LE/CA/BV-03-C: Changed "Steps 2 to 4" to "Steps 2 to 3." Changed "Steps 2 to 6" to "Steps 2 to 5." Updated Initial Condition, Test Procedure, and Pass Verdict of test case TP/RVCV-LE/CA/BV-24-C to align with style in test case TP/RVCV-LE/CA/BV-18-C. Issue 7774: Changed test cases TP/TRM-LE/CA/BV-07-C – 13-C to TP/TRM-LE/CA/BV-08-C – 14-C, respectively, in test case headings, TCMT, and Appendix.
5.0.0r05	2016-10-10	TSE 7551: Deleted notes from test case TP/TRM-LE/CA/BV-01-C.
5.0.0r06	2016-10-12	TSE 7450: Standardized "Pass Verdict" wording for test case TP/TRM-LE/CA/BV-01-C.
5.0.0r07	2016-11-08	Issue 7806: In the TP/TRM-LE/CA/BV-14-C: Updated steps 4-6 (including Figure 4.6) in test procedure to match symbols before and after all 16-symbol blocks; Removed " f0 – f3 " from Pass Verdict, and adjusted "n" range for " fn – f(n-3) ." Issue 7905: For TP/RVCV-LE/CA/BV-09-C, updated interference frequency selection formula in step 4 of test procedure and updated adjacent channels in table and Pass Verdict.
5.0.0r08	2016-11-22	Removed obsolete TC references that got accidentally reintroduced with the Shanghai CRs. Removed TP/TRM-LE/CA/BV-02-C from 6.2.2. Removed TP/TRM-LE/CA/BV-02-C and –BV-04-C as well as TP/RVCV-LE/CA/BV-02-C from 6.2.3
5.0.0	2016-12-13	Approved by BTI. Prepared for TCRL 2016-2 publication.

Revision History	Date	Comments
5.0.1r00	2017-03-08	<p>TSE 7818: In RF-PHY/TRM-LE/CA/BV-01-C, updated Pass Verdict and added IEEE term "shall".</p> <p>TSE 8337: See notes below for TSE 8339.</p> <p>TSE 8338: See notes below for TSE 8339.</p> <p>TSE 8339: In RF-PHY/RVC-LE/CA/BV-03-C and RF-PHY/RVC-LE/CA/BV-09-C, updated figure: Changed interference signal level from "-67dBm + C/I + Lt" to "-67dBm - C/I + Lt". In RF-PHY/RVC-LE/CA/BV-28-C, updated figure: Changed interference signal level from "-89dBm + C/I + Lt" to "-72dBm - C/I + Lt". In RF-PHY/RVC-LE/CA/BV-29-C, updated figure: Changed interference signal level from "-91dBm + C/I + Lt" to "-79dBm - C/I + Lt". Note: TSE 8339 includes TSE 8337 and TSE 8338.</p>
5.0.1r01	2017-05-10	Converted to new Test Case ID conventions as defined in TSTO v4.1.
5.0.1	2017-07-05	Approved by BTI. Prepared for TCRL 2017-1 publication.
5.0.2r00	2017-08-18	<p>TSE 9161: In Frequencies for Testing: Peripheral and Central Devices, reorganized RF-PHY/TRM-LE/CA/BV-13-C and RF-PHY/TRM-LE/CA/BV-14-C and deleted RF-PHY/TRM-LE/CA/BV-04-C in the test case(s) table. Added the following 20 TCIDs to Appendix > In Frequencies for Testing: Broadcaster and Observer Devices section: RF-PHY/TRM-LE/CA/BV-13-C - ...14-C, RF-PHY/RVC-LE/CA/BV-14-C - ...25-C, and RF-PHY/RVC-LE/CA/BV-32-C - ...37-C.</p> <p>TSE 9173: Deleted test in Test Strategy. Deleted Provisional RF Testing and Test Equipment sections from Test Cases > Introduction section.</p>
5.0.2r01	2017-09-19	AoA/AoD: Integrated the AoA/AoD CR into the Reference section and test cases RF-PHY/TRM-LE/CA/BV-01-C, RF-PHY/TRM-LE/CA/BV-06-C, and RF-PHY/TRM-LE/CA/BV-12-C. Added new test cases RF-PHY/TRM-LE/CA/BV-15-C - ...17-C. Added new tests to TCMT.
5.0.2r02	2017-10-02	<p>TSE 9858: Resized RF-PHY/TRM-LE/CA/BV-06-C Figures 4.4 and 4.5 to fit portrait page.</p> <p>TSE 9895: Fixed RF-PHY/RVC-LE/CA/BV-31-C test procedure typo in data coding scheme.</p>
5.0.2r03	2017-10-13	TSE 9859: Revised the RF-PHY/TRM-LE/CA/BV-05-C "Frequency deviation measurement principle for 10101010-payload sequence" figure.
5.0.2r04	2017-10-31	TSE 9161: Reorganized RF-PHY/TRM-LE/CA/BV-13-C and RF-PHY/TRM-LE/CA/BV-14-C in the test case(s) table in "Frequencies for Testing: Peripheral and Central Devices."
5.0.2	2017-12-07	Approved by BTI. Prepared for TCRL 2017-2 publication.

Revision History	Date	Comments
5.0.3r00-02	2018-01-26 – 2018-06-08	<p>Issue 10132 : deleted AoA/AoD text from test cases RF-PHY/TRM-LE/CA/BV-01-C (section 4.4.1), RF-PHY/TRM-LE/CA/BV-06-C (section 4.4.4), and RF-PHY/TRM-LE/CA/BV-12-C (section 4.4.9).</p> <p>TSE 10106 (rating 1): Changed “TRM-LE/CA” to “TRM” and “RCV-LE/CA” to “RCV” in test case names.</p> <p>TSE 10106 : fixed integration error. Applied change to two more instances in test case RF-PHY/TRM/BV-11-C.</p>
5.0.3	2018-07-02	Approved by BTI. Prepared for TCRL 2018-1 publication.
5.0.4r00-r04	2018-08-20 - 2018-10-25	<p>Incorporated RF-PHY.DF.Test CRr09: Added 20 new test cases to spec text, TCMT, and Appendix Table 6.2: RF-PHY/TRM/IQC/BV-01-C – 08-C; RF-PHY/RCV/IQC/BV-01-C – 12-C. Added 2 new sections: "Test Setups Examples" (Section 4.6) and "Error Measurement for IQ Samples" (Section 6.8).</p> <p>Issue 11046: Various clarifications and typo corrections for IQ sample test material. Sections: Tx Power Stability, AoD Transmitter; Antenna switching integrity, AoD Transmitter; IQ Samples Coherency, AoD Receiver; IQ Samples Coherency, AoA Receiver; IQ Samples Dynamic Range, AoD Receiver; IQ Samples Dynamic Range, AoD Receiver; Appendix.</p> <p>Issue 11081: Clarifications and typo corrections for IQ sample test material.</p> <p>Issue 11085: Clarified test procedure step repetition in IQ Samples Coherency and Dynamic Range test cases.</p> <p>TSE 11072 (rating 1): Fixed typo in revision date on first page.</p> <p>TSE 10897 (rating 2): Changed Interference Signal #2 from 1 Ms/s to 2 Ms/s for test case RF-PHY/RCV/BV-11-C.</p> <p>Issue 11082: Comprehensive re-write of the IQ Sample Appendix section for clarity and accuracy.</p> <p>Integration review, renaming from /TRM/IQC/BV-01..-04-C to “/TRM/PS/BV-01-C etc, from /TRM/IQC/BV-05..08-C to /TRM/ASI/BV-05-C etc, from /RCV/IQC/BV-07..-12-C to /RCV/IQDR/BV-07 etc</p>
5.1.0	2018-11-13	Updated revision number to 5.1.0 to align with the adoption of Core Specification version 5.1
5.1.0	2018-12-07	Approved by BTI. Prepared for TCRL 2018-2 publication.

Revision History	Date	Comments
5.1.1r00-r02	2019-03-29– 2019-05-15	TSE 11535 (rating 1): Updated TCMT Item to LL 9/22 for test cases RF-PHY/TRM/PS/BV-02-C, 04-C; and RF-PHY/TRM/ASI/BV-06-C, BV-08-C. TSE 11732 (rating 1): Updated the test procedure in the "IQ Samples Dynamic Range, AoD Receiver" and "IQ Samples Dynamic Range, AoA Receiver" sections. TSE 11791 (rating 2): TCMT-only change to accommodate ICS/IXIT updates.
5.1.1	2019-08-01	Approved by BTI. Prepared for TCRL 2019-1 publication.

Contributors

Name	Company
Frank Karlsen	Nordic Semiconductor A/S
Tor Ø. Vedal	Nordic Semiconductor A/S
Jukka Reunamaki	Nokia
Ole Myrtue	Nokia
Magnus Sommansson	CSR
Juan Manuel Hidalgo Perdiguero	AT4 wireless
Ángel Romero	AT4 wireless
Edward Harrison	Anritsu
Paul vanOostende	ST Microelectronics
Peter Dziwior	Rohde & Schwarz
Nils Schapmann	7 Layers
Rogier Schaeffer	ST Microelectronics
Steven Wenham	CSR
Peter Flittner	CSR
Norbert Grünert	Broadcom
Dave Richter	Qualcomm
Magnus Sommansson	Qualcomm

