

8 7 6 5 4 3 2 1

NOTES: (UNLESS OTHERWISE SPECIFIED)

1. REFERENCE SPEC. <F03-017>
2. MATERIAL TO BE DISSIPATIVE, REFER TO SPEC. <F16-055.8>
3. * DENOTES CRITICAL DIMENSION.
4. VOIDS (NON-FILLS) IN THE FENCE AREA OF POCKETS WHERE SUBSEQUENT FENCE HEIGHT IS LESS THAN 22 MILS CANNOT HAVE A HORIZONTAL DIMENSION OR GREATER THAN 100 MILS. FOR A SINGLE VOID AND CUMULATIVE 200 MILS FOR ALL VOID ON A SINGLE FENCE.
5. ALL DIMENSIONS ARE IN MILIMETERS.
6. TOLERANCES:
 .XX = ±0.13
 .X = ±0.25 ANGLE = ±0.5°
7. TRAY COLOR: BLACK
 MATERIAL: MPPO
8. LOW TEMP. INTRINSIC COLOR TRAY MADE FROM THE FOLLOWING MATERIALS: ABS, PS OR EQUIVALENT SHALL BE USED FOR INTERNAL PROCESS ONLY.

D

D

C

C

B

B

A

A

ALL INFORMATION HEREON IS COMPANY PRIVATE AND THE PROPERTY OF SPANSION LLC AND SHALL NOT BE REPRODUCED OR COPIED OR USED IN WHOLE OR PART AS THE BASIS OF MANUFACTURE OR SALE OF PRODUCT(S) EXCEPT AS EXPRESSLY PERMITTED OR DIRECTED BY SPANSION LLC.

FILENAME F04-0028809		 915 DeGuerre Dr. Sunnyvale, CA. 94088-3453			
APPROVALS	DATE	TRAY FOR VDG048, UNE008 (6 X 5 MM)			
DRAWN ROLASO	11/15/06	SIZE	CLASS F04	DWG. NUMBER 0028809	DWG REV -
APPROVED KW-LAI	11/15/06	SCALE: N/A	FMO Engineering	SHEET 1 OF 5	
SmarTeam					

8 7 6 5 4 3 2 1

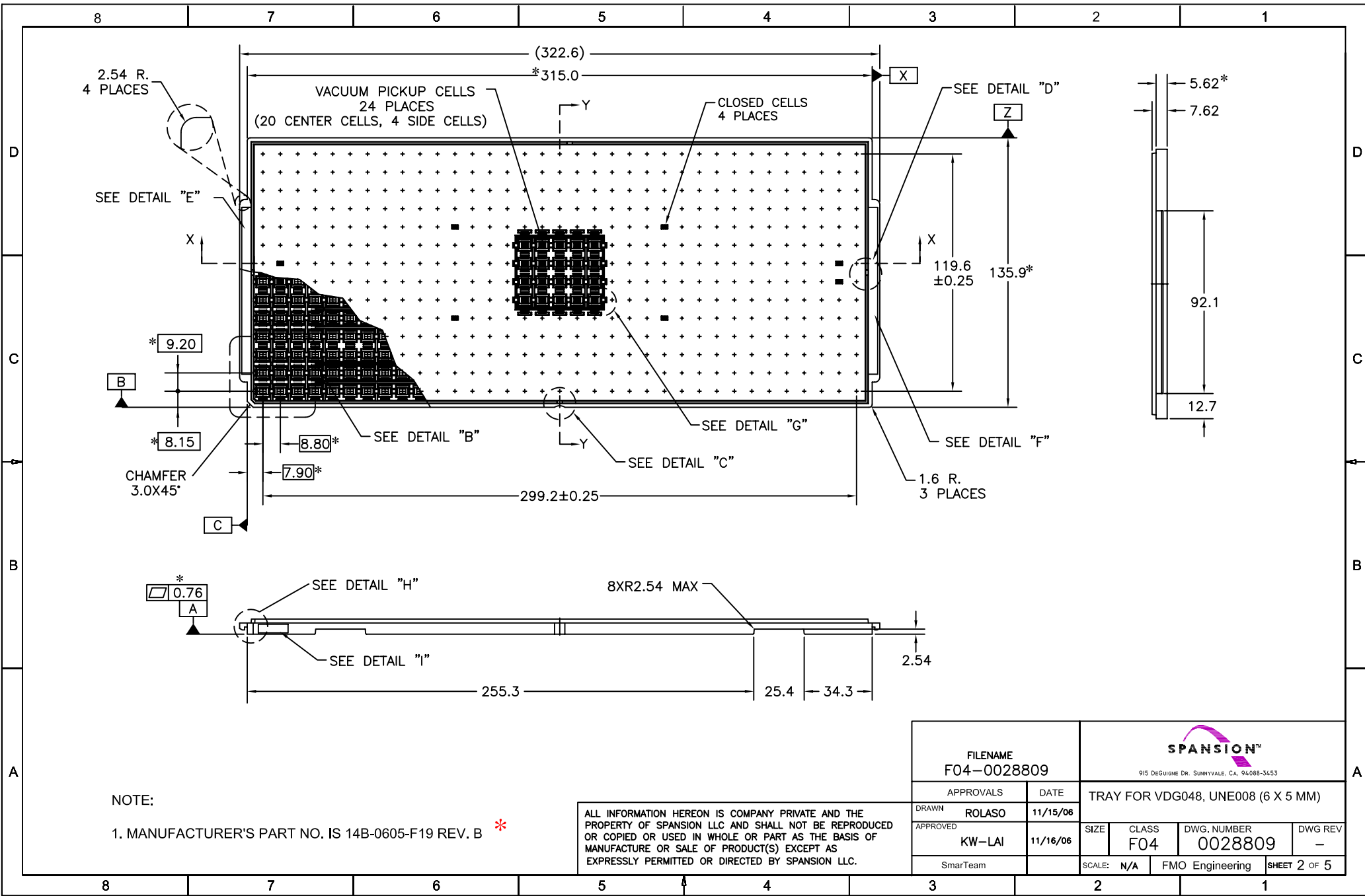

NOTE:

1. MANUFACTURER'S PART NO. IS 14B-0605-F19 REV. B *

ALL INFORMATION HEREON IS COMPANY PRIVATE AND THE PROPERTY OF SPANSION LLC AND SHALL NOT BE REPRODUCED OR COPIED OR USED IN WHOLE OR PART AS THE BASIS OF MANUFACTURE OR SALE OF PRODUCT(S) EXCEPT AS EXPRESSLY PERMITTED OR DIRECTED BY SPANSION LLC.

FILENAME F04-0028809		 915 DeGuerre Dr. Sunnyvale, CA. 94088-3453		
APPROVALS	DATE	TRAY FOR VDG048, UNE008 (6 X 5 MM)		
DRAWN ROLASO	11/15/06	SIZE	CLASS F04	DWG. NUMBER 0028809
APPROVED KW-LAI	11/16/06			DWG REV -
SmarTeam		SCALE: N/A	FMO Engineering	SHEET 2 OF 5

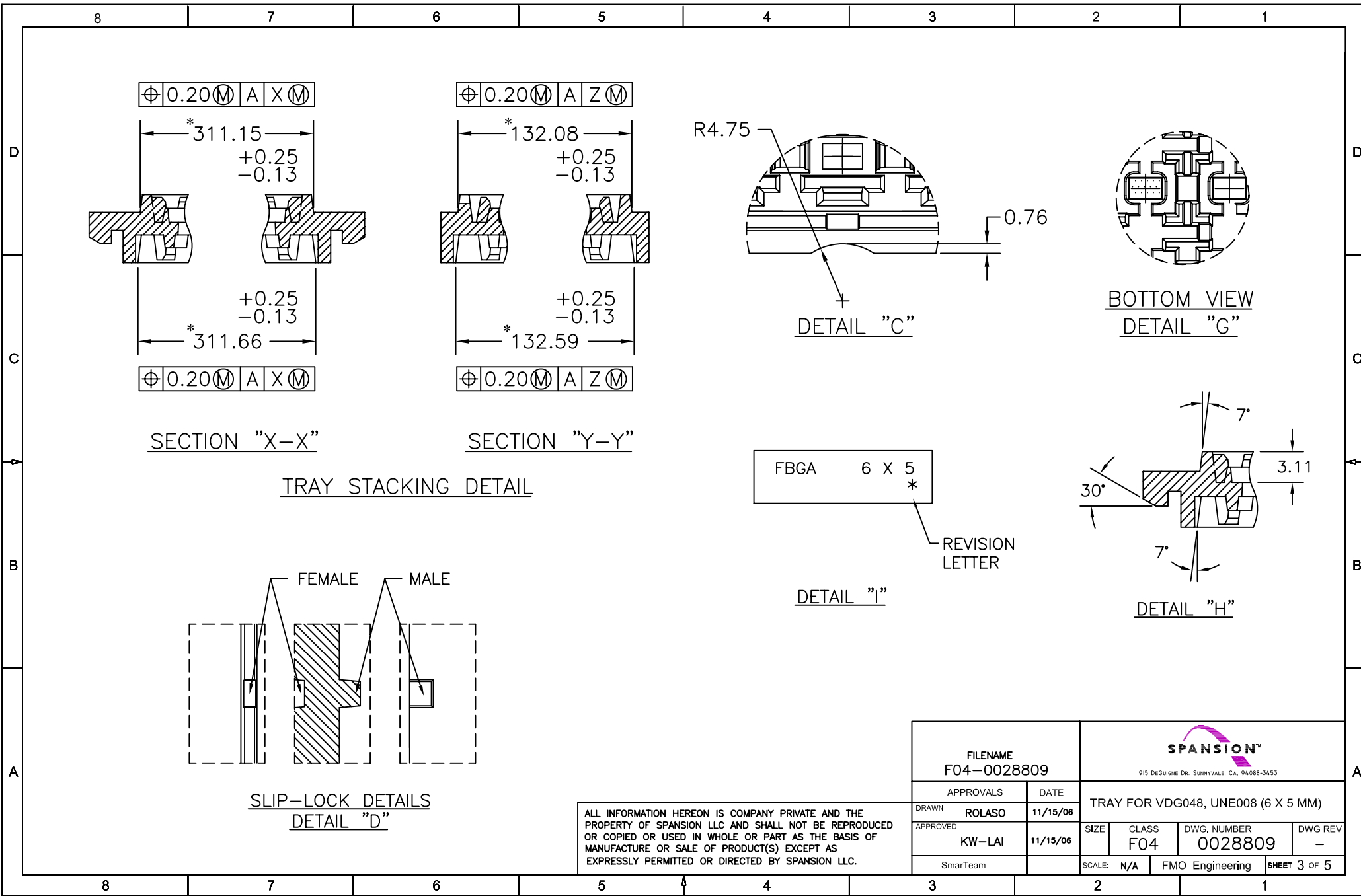

⌀0.20 (M) A X (M)

⌀0.20 (M) A Z (M)

*311.15
 +0.25
 -0.13

*132.08
 +0.25
 -0.13

+0.25
 -0.13
 *311.66

+0.25
 -0.13
 *132.59

⌀0.20 (M) A X (M)

⌀0.20 (M) A Z (M)

SECTION "X-X"

SECTION "Y-Y"

TRAY STACKING DETAIL

R4.75
 0.76
 DETAIL "C"

BOTTOM VIEW
 DETAIL "G"

FBGA 6 X 5 *
 REVISION LETTER
 DETAIL "I"

7°
 30°
 7°
 3.11
 DETAIL "H"

FEMALE
 MALE
 SLIP-LOCK DETAILS
 DETAIL "D"

ALL INFORMATION HEREON IS COMPANY PRIVATE AND THE PROPERTY OF SPANSION LLC AND SHALL NOT BE REPRODUCED OR COPIED OR USED IN WHOLE OR PART AS THE BASIS OF MANUFACTURE OR SALE OF PRODUCT(S) EXCEPT AS EXPRESSLY PERMITTED OR DIRECTED BY SPANSION LLC.

FILENAME F04-0028809		 915 DEGRUNE DR. SUNNYVALE, CA. 94088-3453		
APPROVALS	DATE	TRAY FOR VDG048, UNE008 (6 X 5 MM)		
DRAWN ROLASO	11/15/06	SIZE	CLASS F04	DWG. NUMBER 0028809
APPROVED KW-LAI	11/15/06			DWG REV -
SmarTeam		SCALE: N/A	FMO Engineering	SHEET 3 OF 5

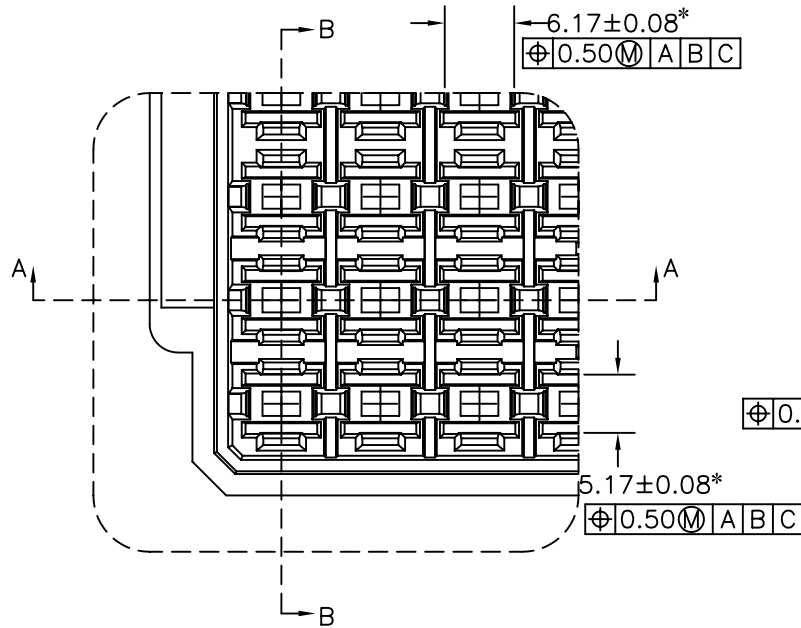

TOP VIEW
 DETAIL "B"

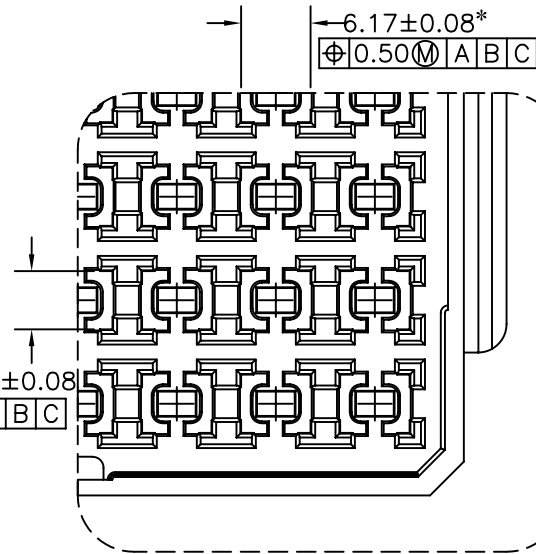

BOTTOM VIEW
 DETAIL "B"

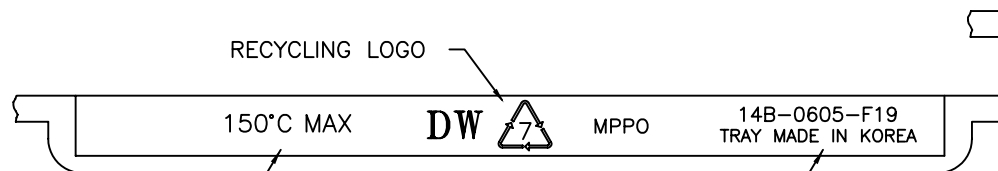
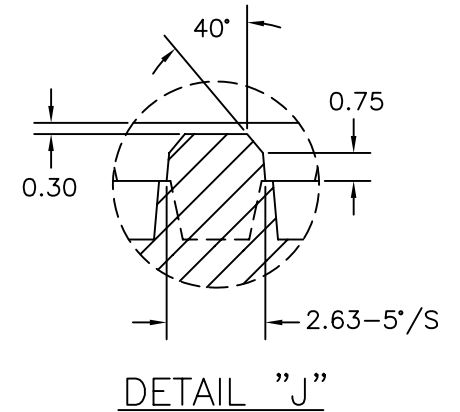

TEMPERATURE
 RATING BLOCK

DETAIL "F"

DAEWON PART NO.

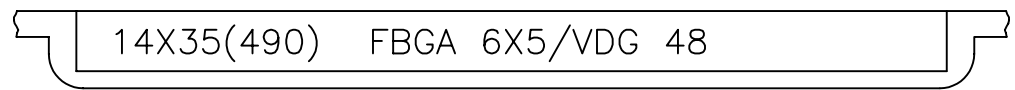

DETAIL "E"

ALL INFORMATION HEREON IS COMPANY PRIVATE AND THE
 PROPERTY OF SPANSION LLC AND SHALL NOT BE REPRODUCED
 OR COPIED OR USED IN WHOLE OR PART AS THE BASIS OF
 MANUFACTURE OR SALE OF PRODUCT(S) EXCEPT AS
 EXPRESSLY PERMITTED OR DIRECTED BY SPANSION LLC.

FILENAME F04-0028809		 915 DeGuerre Dr. Sunnyvale, CA. 94088-3453		
APPROVALS	DATE	TRAY FOR VDG048, UNE008 (6 X 5 MM)		
DRAWN ROLASO	11/15/06	SIZE	CLASS F04	DWG. NUMBER 0028809
APPROVED KW-LAI	11/15/06			DWG REV -
SmarTeam		SCALE: N/A	FMO Engineering	SHEET 4 OF 5

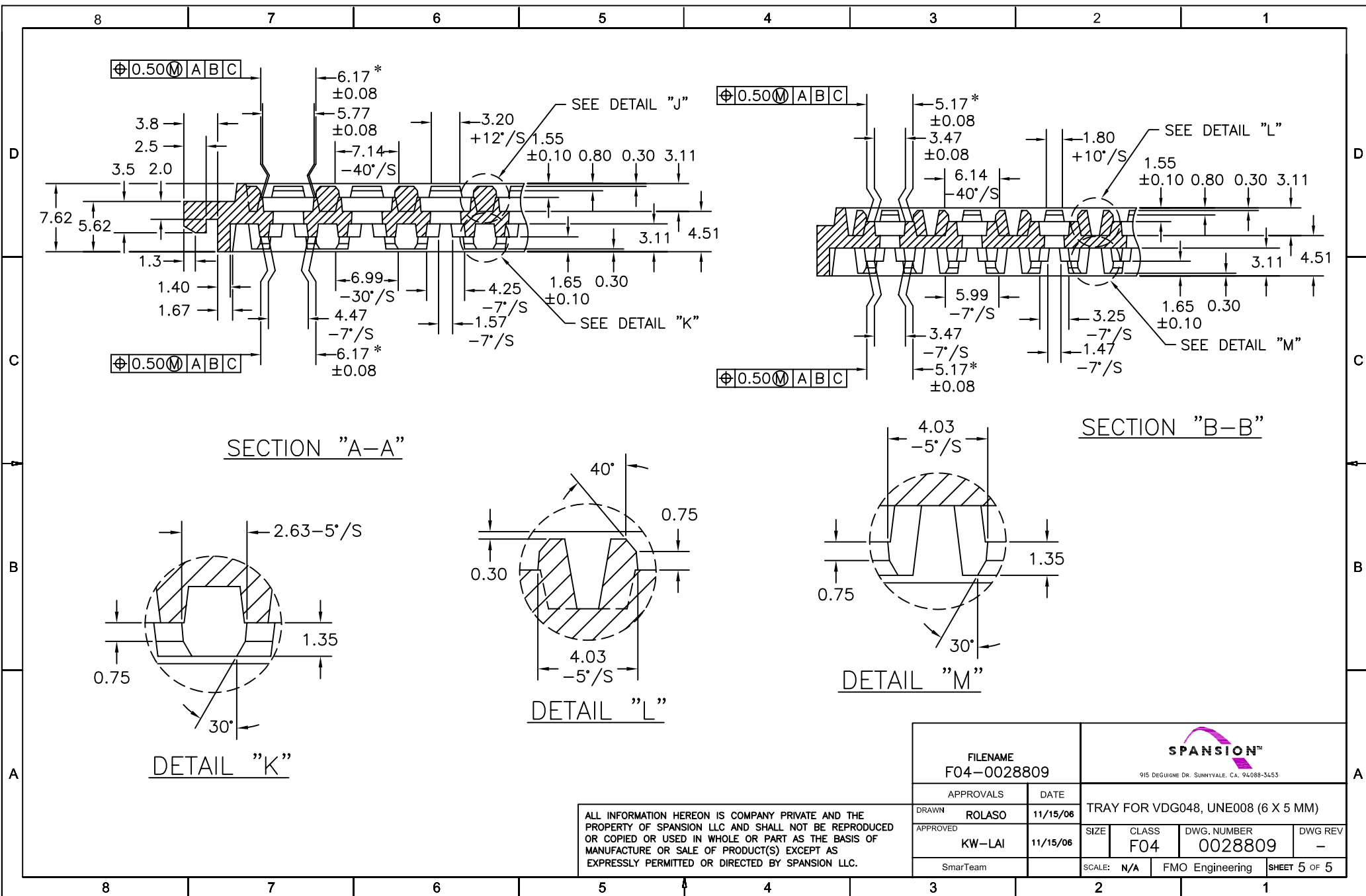

ALL INFORMATION HEREON IS COMPANY PRIVATE AND THE PROPERTY OF SPANSION LLC AND SHALL NOT BE REPRODUCED OR COPIED OR USED IN WHOLE OR PART AS THE BASIS OF MANUFACTURE OR SALE OF PRODUCT(S) EXCEPT AS EXPRESSLY PERMITTED OR DIRECTED BY SPANSION LLC.

FILENAME F04-0028809		 915 DeGuerre Dr. Sunnyvale, CA. 94088-3453		
APPROVALS	DATE	TRAY FOR VDG048, UNE008 (6 X 5 MM)		
DRAWN ROLASO	11/15/06	SIZE	CLASS F04	DWG. NUMBER 0028809
APPROVED KW-LAI	11/15/06			DWG REV -
SmarTeam		SCALE: N/A	FMO Engineering	SHEET 5 OF 5