



WICED Studio



# WICED HCI UART Control Protocol

Associated Part Families: CYW20706, CYW20719, CYW20735  
Doc. No.: 002-16618 Rev. \*A

Cypress Semiconductor  
198 Champion Court  
San Jose, CA 95134-1709  
[www.cypress.com](http://www.cypress.com)

# Contents

<b>About This Document</b> .....	<b>8</b>
Purpose and Audience .....	8
Scope .....	8
Acronyms and Abbreviations .....	8
IoT Resources and Technical Support .....	8
Hardware and Software Prerequisites .....	8
<b>1 Introduction</b> .....	<b>9</b>
<b>2 Downloading an Application and Configuration Data</b> .....	<b>10</b>
2.1 Introduction.....	10
2.2 Preparing for HCI commands .....	10
2.3 Download File Formats.....	10
2.4 Downloading the Application to RAM .....	11
2.4.1 HCI Commands and Events During a RAM Download.....	12
2.5 Downloading the Application to Serial Flash .....	14
2.6 HCI Commands and Events During a Serial Flash Download.....	14
<b>3 WICED HCI Control Protocol Definition</b> .....	<b>16</b>
<b>4 WICED HCI Control Protocol Commands</b> .....	<b>17</b>
4.1 Device Commands: HCI_CONTROL_GROUP_DEVICE .....	17
4.1.1 Reset .....	17
4.1.2 Trace Enable .....	17
4.1.3 Set Local Bluetooth Device Address.....	18
4.1.4 Set Baud Rate .....	18
4.1.5 Push NVRAM Data .....	18
4.1.6 Delete NVRAM Data.....	18
4.1.7 Inquiry.....	19
4.1.8 Set Visibility .....	19
4.1.9 Set Pairing Mode .....	19
4.1.10 Unbond.....	20
4.1.11 User Confirmation.....	20
4.1.12 Enable Coexistence.....	20
4.1.13 Disable Coexistence .....	20
4.1.14 Set Battery Level .....	21
4.1.15 Read Local Bluetooth Device Address .....	21
4.1.16 Start Bond.....	21
4.1.17 Read Buffer Pool Usage Statistics.....	21
4.2 LE Commands: HCI_CONTROL_GROUP_LE .....	22
4.2.1 LE Scan .....	22
4.2.2 LE Advertise .....	23
4.2.3 LE Connect.....	24
4.2.4 LE Cancel Connect.....	24
4.2.5 LE Disconnect .....	24
4.2.6 LE Re Pair .....	25
4.2.7 LE Get Identity Address.....	25
4.2.8 LE Set Channel Classification .....	25
4.2.9 LE Set Connection Parameters .....	26
4.3 GATT Commands: HCI_CONTROL_GROUP_GATT .....	26
4.3.1 GATT Discover Services .....	26
4.3.2 GATT Discover Characteristics .....	27
4.3.3 GATT Discover Descriptors .....	27
4.3.4 GATT Command Read Request.....	28

4.3.5	GATT Command Read Response .....	29
4.3.6	GATT Command Write .....	30
4.3.7	GATT Command Write Request .....	31
4.3.8	GATT Command Write Response .....	32
4.3.9	GATT Command Notify .....	33
4.3.10	GATT Command Indicate .....	34
4.3.11	GATT Command Indicate Confirm .....	35
4.4	Hands-Free Commands— HCI_CONTROL_GROUP_HF .....	35
4.4.1	HF Connect .....	35
4.4.2	HF Disconnect .....	35
4.4.3	HF Open Audio .....	36
4.4.4	HF Close Audio .....	36
4.4.5	HF Accept/Reject Audio Connection .....	36
4.4.6	HF AT Commands .....	37
4.5	Serial Port Profile Commands—HCI_CONTROL_GROUP_SPP .....	38
4.5.1	SPP Connect .....	38
4.5.2	SPP Disconnect .....	38
4.5.3	SPP Data .....	38
4.6	Audio Commands— HCI_CONTROL_GROUP_AUDIO .....	39
4.6.1	Audio Connect .....	39
4.6.2	Audio Disconnect .....	39
4.6.3	Audio Start .....	39
4.6.4	Audio Stop .....	40
4.6.5	Audio Data .....	40
4.7	HID Device Commands: HCI_CONTROL_GROUP_HIDD .....	41
4.7.1	HID Accept Pairing .....	41
4.7.2	HID Send Report .....	41
4.7.3	HID Push Pairing Host Info .....	41
4.7.4	HID Connect .....	42
4.8	AV Remote Control Target Commands: HCI_CONTROL_GROUP_AVRC_TARGET .....	42
4.8.1	AVRC Target Connect .....	42
4.8.2	AVRC Target Disconnect .....	42
4.8.3	AVRC Target Track Information .....	43
4.8.4	AVRC Target Player Status .....	43
4.8.5	AVRC Target Repeat Mode Changed .....	44
4.8.6	AVRC Target Shuffle Mode Changed .....	44
4.8.7	AVRC Target Equalizer Status Changed .....	44
4.8.8	AVRC Target Scan Mode Changed .....	44
4.9	AV Remote Control Controller Commands: HCI_CONTROL_GROUP_AVRC_CONTROLLER .....	45
4.9.1	AVRC Controller Connect .....	45
4.9.2	AVRC Controller Disconnect .....	45
4.9.3	AVRC Controller Play .....	45
4.9.4	AVRC Controller Stop .....	46
4.9.5	AVRC Controller Pause .....	46
4.9.6	AVRC Controller Begin Fast Forward .....	46
4.9.7	AVRC Controller End Fast Forward .....	46
4.9.8	AVRC Controller Begin Rewind .....	47
4.9.9	AVRC Controller End Rewind .....	47
4.9.10	AVRC Controller Next Track .....	47
4.9.11	AVRC Controller Previous Track .....	47
4.9.12	AVRC Controller Volume Up .....	48
4.9.13	AVRC Controller Volume Down .....	48
4.9.14	AVRC Controller Get Track Information .....	48
4.9.15	AVRC Controller Set Equalizer Status .....	49
4.9.16	AVRC Controller Set Repeat Mode .....	49
4.9.17	AVRC Controller Set Shuffle Mode .....	49
4.9.18	AVRC Controller Set Scan Status .....	50
4.9.19	AVRC Controller Set Volume .....	50
4.10	Test Commands— HCI_CONTROL_GROUP_TEST .....	50
4.10.1	Encapsulated HCI Command .....	50

4.11	ANCS Commands: HCI_CONTROL_GROUP_ANCS .....	51
4.11.1	ANCS Action .....	51
4.11.2	ANCS Connect .....	51
4.11.3	ANCS Disconnect .....	51
4.12	AMS Commands: HCI_CONTROL_GROUP_AMS .....	52
4.12.1	AMS Connect .....	52
4.12.2	AMS Disconnect .....	52
4.13	iAP2 Commands: HCI_CONTROL_GROUP_IAP2 .....	52
4.13.1	IAP2 Connect .....	52
4.13.2	IAP2 Disconnect .....	53
4.13.3	IAP2 Data .....	53
4.13.4	IAP2 Get Auth Chip Info .....	53
4.14	Hands-free AG Commands: HCI_CONTROL_GROUP_AG .....	54
4.14.1	AG Connect .....	54
4.14.2	AG Disconnect .....	54
4.14.3	AG Audio Connect .....	54
4.14.4	AG Audio Disconnect .....	55
4.15	AIO Server Commands: HCI_CONTROL_GROUP_AIO_SERVER .....	55
4.15.1	AIO Digital Input .....	55
4.15.2	AIO Analog Input .....	55
4.16	AIO Client Commands: HCI_CONTROL_GROUP_AIO_CLIENT .....	56
4.16.1	AIO Connect .....	56
4.16.2	AIO Read .....	56
4.16.3	AIO Write .....	56
4.16.4	AIO Register for Notification .....	57
4.16.5	AIO Set Value Trigger .....	57
4.16.6	AIO Set Time Trigger .....	58
4.16.7	AIO Set User Description .....	58
4.16.8	AIO Disconnect .....	58
4.17	Audio Sink Commands: HCI_CONTROL_GROUP_AUDIO_SINK .....	58
4.17.1	Audio Sink Connect .....	59
4.17.2	Audio Sink Disconnect .....	59
4.17.3	Audio Sink Start .....	59
4.17.4	Audio Sink Stop .....	59
4.17.5	Audio Sink Start Response .....	60
4.17.6	Audio Sink Change Route .....	60
4.18	Miscellaneous Commands: HCI_CONTROL_GROUP_MISC .....	60
4.18.1	Ping Request .....	60
4.18.2	Get Version .....	61
<b>5</b>	<b>WICED HCI Control Protocol Events .....</b>	<b>62</b>
5.1	Device Events: HCI_CONTROL_GROUP_DEVICE .....	62
5.1.1	Command Status .....	62
5.1.2	WICED Trace .....	62
5.1.3	HCI Trace .....	63
5.1.4	NVRAM Data .....	63
5.1.5	Device Started .....	63
5.1.6	Inquiry Result .....	64
5.1.7	Inquiry Complete .....	64
5.1.8	Pairing Completed .....	64
5.1.9	Encryption Changed .....	65
5.1.10	Connected Device Name .....	65
5.1.11	User Confirmation Request .....	65
5.1.12	Device Error .....	65
5.1.13	Local Bluetooth Device Address .....	66
5.1.14	Maximum Number of Paired Devices Reached .....	66
5.1.15	Buffer Pool Usage Statistics .....	66
5.2	LE Events—HCI_CONTROL_GROUP_LE .....	67
5.2.1	LE Command Status .....	67

5.2.2	LE Scan Status .....	67
5.2.3	LE Advertisement Report .....	67
5.2.4	LE Advertisement State .....	68
5.2.5	LE Connected .....	68
5.2.6	LE Disconnected .....	68
5.2.7	LE Identity Address .....	69
5.2.8	LE Peer MTU .....	69
5.2.9	LE Connection Parameters .....	69
5.3	GATT Events .....	70
5.3.1	GATT Command Status .....	70
5.3.2	GATT Discovery Complete .....	70
5.3.3	GATT Service Discovered .....	70
5.3.4	GATT Characteristic Discovered .....	71
5.3.5	GATT Descriptor Discovered .....	71
5.3.6	GATT Event Read Request .....	72
5.3.7	GATT Event Read Response .....	72
5.3.8	GATT Event Write Request .....	72
5.3.9	GATT Event Write Response .....	73
5.3.10	GATT Event Indication .....	73
5.3.11	GATT Event Notification .....	74
5.3.12	GATT Event Read Error .....	74
5.3.13	GATT Event Write Request Error .....	74
5.4	HF Events: HCI_CONTROL_GROUP_HF .....	75
5.4.1	HF Open .....	75
5.4.2	HF Close .....	75
5.4.3	HF Connected .....	75
5.4.4	HF Audio Open .....	75
5.4.5	HF Audio Close .....	76
5.4.6	HF Audio Connection Request .....	76
5.4.7	HF Response .....	76
5.5	SPP Events—HCI_CONTROL_GROUP_SPP .....	78
5.5.1	SPP Connected .....	78
5.5.2	SPP Service Not Found .....	78
5.5.3	SPP Connection Failed .....	78
5.5.4	SPP Disconnected .....	78
5.5.5	SPP TX Complete .....	79
5.5.6	SPP RX Data .....	79
5.5.7	SPP Command Status .....	79
5.6	Audio Events—HCI_CONTROL_GROUP_AUDIO .....	80
5.6.1	Audio Command Status .....	80
5.6.2	Audio Connected .....	80
5.6.3	Audio Service Not Found .....	81
5.6.4	Audio Connection Failed .....	81
5.6.5	Audio Disconnected .....	81
5.6.6	Audio Data Request .....	81
5.6.7	Audio Started .....	82
5.6.8	Audio Stopped .....	82
5.7	AV Remote Control Controller Events: HCI_CONTROL_GROUP_AVRC_CONTROLLER .....	82
5.7.1	AVRC Controller Connected .....	82
5.7.2	AVRC Controller Disconnected .....	82
5.7.3	AVRC Controller Current Track Info .....	83
5.7.4	AVRC Controller Play Status .....	83
5.7.5	AVRC Controller Play Position .....	84
5.7.6	AVRC Controller Track Change .....	84
5.7.7	AVRC Controller Track End .....	84
5.7.8	AVRC Controller Track Start .....	84
5.7.9	AVRC Controller Settings Available .....	85
5.7.10	AVRC Controller Setting Change .....	86
5.7.11	AVRC Controller Player Change .....	86
5.7.12	AVRC Controller Command Status .....	87
5.8	AV Remote Control Target Events: HCI_CONTROL_GROUP_AVRC_TARGET .....	87

5.8.1	AVRC Target Connected	87
5.8.2	AVRC Target Disconnected	87
5.8.3	AVRC Target Play	87
5.8.4	AVRC Target Stop	88
5.8.5	AVRC Target Pause	88
5.8.6	AVRC Target Next Track	88
5.8.7	AVRC Target Previous Track	88
5.8.8	AVRC Target Begin Fast Forward	88
5.8.9	AVRC Target End Fast Forward	89
5.8.10	AVRC Target Begin Rewind	89
5.8.11	AVRC Target End Rewind	89
5.8.12	AVRC Target Volume Level	89
5.8.13	AVRC Target Repeat Settings	90
5.8.14	AVRC Target Shuffle Settings	90
5.8.15	AVRC Target Command Status	90
5.9	HID Device Events: HCI_CONTROL_GROUP_HIDD	91
5.9.1	HID Opened	91
5.9.2	HID Virtual Cable Unplugged	91
5.9.3	HID Data	91
5.9.4	HID Closed	91
5.10	AIO Server Events: HCI_CONTROL_GROUP_AIO_SERVER	92
5.10.1	AIO Digital Output	92
5.10.2	AIO Analog Output	92
5.11	AIO Client Events: HCI_CONTROL_GROUP_AIO_CLIENT	93
5.11.1	AIO Command Status	93
5.11.2	AIO Connected	93
5.11.3	AIO Read Response	93
5.11.4	AIO Write Response	94
5.11.5	AIO Input	94
5.11.6	AIO Disconnected	94
5.12	Current Time Events: HCI_CONTROL_GROUP_TIME	95
5.12.1	Time Update	95
5.13	Test Events: HCI_CONTROL_GROUP_TEST	96
5.13.1	Encapsulated HCI Event	96
5.14	ANCS Events: HCI_CONTROL_GROUP_ANCS	96
5.14.1	ANCS Notification	96
5.14.2	ANCS Command Status	97
5.14.3	ANCS Service Found	97
5.14.4	ANCS Connected	97
5.14.5	ANCS Disconnected	98
5.15	AMS Events: HCI_CONTROL_GROUP_AMS	98
5.15.1	AMS Command Status	98
5.15.2	AMS Service Found	98
5.15.3	AMS Connected	98
5.15.4	AMS Disconnected	99
5.16	Alert Events: HCI_CONTROL_GROUP_ALERT	99
5.16.1	Alert Notification	99
5.17	iAP2 Events: HCI_CONTROL_GROUP_IAP2	99
5.17.1	IAP2 Connected	99
5.17.2	IAP2 Service Not Found	100
5.17.3	IAP2 Connection Failed	100
5.17.4	IAP2 Disconnected	100
5.17.5	IAP2 TX Complete	100
5.17.6	IAP2 RX Data	101
5.17.7	IAP2 Auth Chip Info	101
5.17.8	IAP2 Auth Chip Certificate	101
5.17.9	IAP2 Auth Chip Signature	101
5.18	AG Events: HCI_CONTROL_GROUP_AG	102
5.18.1	AG Open	102

5.18.2	AG Close .....	102
5.18.3	AG Connected .....	102
5.18.4	AG Audio Open.....	103
5.18.5	AG Audio Close .....	103
5.19	Audio Sink Events: HCI_CONTROL_GROUP_AUDIO_SINK .....	103
5.19.1	Audio Sink Command Status.....	103
5.19.2	Audio Sink Connected .....	103
5.19.3	Audio Sink Service Not Found.....	104
5.19.4	Audio Sink Connection Failed.....	104
5.19.5	Audio Sink Disconnected.....	104
5.19.6	Audio Sink Started.....	104
5.19.7	Audio Sink Stopped .....	104
5.19.8	Audio Sink Codec Configured.....	105
5.19.9	Audio Sink Start Indication.....	105
5.19.10	Audio Sink Data .....	105
5.20	Miscellaneous Events: HCI_CONTROL_GROUP_MISC .....	107
5.20.1	Ping Request Reply .....	107
5.20.2	Version Info .....	107
<b>References.....</b>		<b>108</b>
<b>Document Revision History .....</b>		<b>109</b>
<b>Worldwide Sales and Design Support.....</b>		<b>110</b>
	Products .....	110
	PSoC® Solutions.....	110
	Cypress Developer Community .....	110
	Technical Support.....	110

# About This Document

## Purpose and Audience

This document provides information on an HCI UART control protocol. The protocol is an implementation example of how a host microcontroller unit (MCU) can communicate with a Cypress WICED device via HCI UART.

This document is intended for application developers using the WICED Studio Bluetooth Software Development Kit to create and test designs based on Cypress WICED Bluetooth devices.

## Scope

Several paragraphs in the document refer the reader to variables and data structures that are not described in this document. For information on the variables and data structures mentioned in this document, see the API Reference Guide (API.html) that is provided with WICED Studio under the Doc folder.

## Acronyms and Abbreviations

In most cases, acronyms and abbreviations are defined on first use.

For a comprehensive list of acronyms and other terms used in Cypress documents, go to [www.cypress.com/glossary](http://www.cypress.com/glossary).

## IoT Resources and Technical Support

Cypress provides a wealth of data at [www.cypress.com/internet-things-iot](http://www.cypress.com/internet-things-iot) to help you to select the right IoT device for your design, and quickly and effectively integrate the device into your design. Cypress provides customer access to a wide range of information, including technical documentation, schematic diagrams, product bill of materials, PCB layout information, and software updates. Customers can acquire technical documentation and software from the Cypress Support Community website ([community.cypress.com/](http://community.cypress.com/)).

## Hardware and Software Prerequisites

To fully use the content provided in this document, readers will need the following items:

- One CYW20706-, CYW20719- or CYW20735-based Bluetooth (BT) device (referred to as CYW207xx device in this document) and a second BT device, which can also be based on a similar CYW207xx device.
- Version 4.0 or greater of WICED Studio, which includes several applications that use the HCI control protocol defined in this document.
- The Cypress-supplied ClientControl.exe sample application (included with WICED Studio).
- A PC running Windows 7 or higher, Mac OS X 10.10 or higher, Ubuntu Linux 16 or higher, or Fedora Linux 23 or higher.

**Note:** A PC running the ClientControl.exe application is used in place of an external MCU to send commands to and receive replies and asynchronous events from a CYW207xx.

To prepare a CYW207xx-based Bluetooth device, build an application from WICED Studio that uses the HCI control protocol defined in this document. For help doing such a build, see the WICED Kit Guide for the CYW207xx device you are using, for example the CYW20706 WICED Kit Guide [1].

**Note:** Throughout the document, references to the ams application are applicable to any application running on the CYW207xx that supports the HCI control protocol defined in this document. Any sample application that calls the `wiced_transport_init()` API with a valid callback in the `wiced_transport_data_handler_t` member of the parameter struct supports the HCI control protocol defined in this document. WICED Studio contains several such applications (for example, `ancs` and `serial_gatt_service`).



# 1 Introduction

The Cypress WICED Studio SDK includes sample applications that can be executed on CYW207xx devices.

A real Bluetooth product could have an onboard MCU that uses CYW207xx device to provide Bluetooth functionality. For such a product, MCU software would likely be used to control the device through a UART or SPI interface via a protocol that allows the MCU to send and receive commands, events, and data. This document describes a sample protocol for communication between an MCU and a CYW207xx device.

The CYW207xx devices support two operating modes: the Bluetooth Host Controller Interface (HCI) mode and the Application mode. In the Bluetooth HCI mode, the embedded stack in the device is not exercised and the device behaves as a standard Bluetooth HCI controller. A standard Bluetooth HCI controller supports the Bluetooth HCI interface as defined in the Bluetooth Core specification [2]. In the Application mode, the embedded stack in the CYW207xx device is used and the device does not behave as a standard Bluetooth controller.

Figure 1-1 shows the Bluetooth HCI mode and Application mode logical interfaces. In the Bluetooth HCI mode, the MCU communicates to the CYW207xx device using the standard Bluetooth HCI protocol. In the Application mode, the MCU uses the WICED HCI protocol defined in this document.

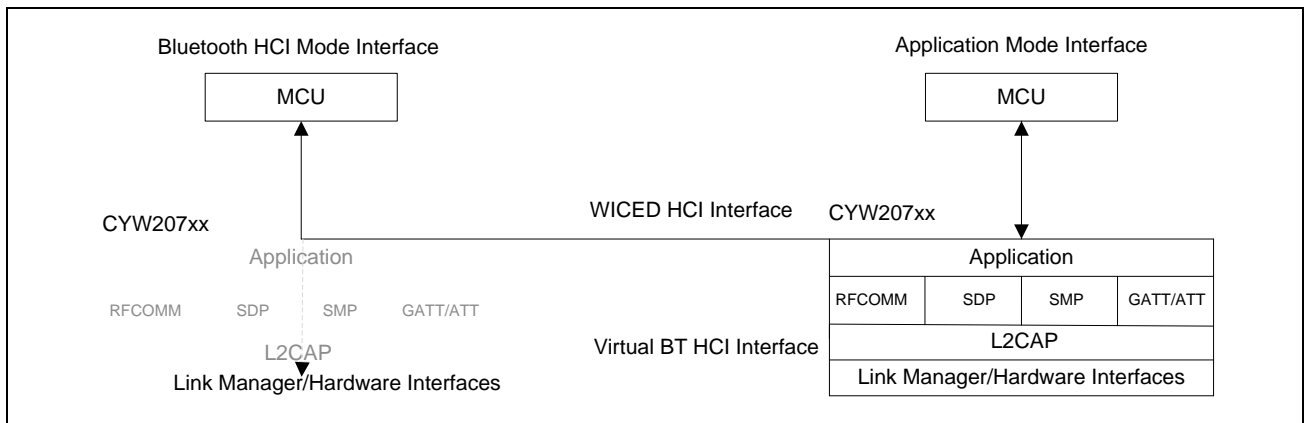

Figure 1-1. CYW207xx MCU Interfaces in the Bluetooth HCI and Application Modes

This document provides a sample protocol, referred to as the WICED HCI Control Protocol, which can be used in the Application mode to support communication between an MCU (host) and an application running on the CYW207xx device (controller). The combination of the ClientControl.exe application (hereinafter referred to as ClientControl) running on a PC and the application running on a CYW207xx device provides a sample implementation of the WICED HCI Control Protocol.

When the CYW207xx device powers on, boot logic determines whether a serial flash is connected and, if so, whether it contains a valid application image. If there is a valid application, the CYW207xx device loads and executes the application. If there is no serial flash, then the CYW207xx device boots into and stays in the Bluetooth HCI mode where it waits for MCU (host) commands. While in Bluetooth HCI mode, the standard Bluetooth HCI protocol is used to download an application to the CYW207xx device and change the device mode to Application mode. Note that the application may be downloaded and then executed from RAM, or may be downloaded to serial flash and then executed on the subsequent device reboot.

The procedure for downloading an application is described in “[Downloading an Application and Configuration Data Using ClientControl.exe](#)”. The procedure is not applicable when serial flash contains a valid application.

The WICED HCI Control Protocol is defined in “[WICED HCI Control Protocol Definition](#)”.

## 2 Downloading an Application and Configuration Data

### 2.1 Introduction

This section describes the process of downloading an application to a CYW207xx device. The first scenario describes the use of a ClientControl.exe application executing on a host PC (in place of a host MCU) to download an embedded application and its associated configuration data to RAM in a CYW207xx device. The second scenario describes the WICED build download process, which writes application and configuration data to serial flash before restarting the CYW207xx device.

**Note:** The code present in the ROM is in most cases sufficient to perform the download. Meanwhile in some cases the MCU needs to load the minidriver which is used during the remainder of the download process. The minidriver is a set of code and data that replaces the download code in the ROM of the CYW207xx device. The minidriver download provides a way to adapt the download process to handle scenarios that the ROM code does not. For example, a design using the CYW207xx may require downloading to a serial flash that requires a different protocol than the ROM can supply. Downloading a minidriver that supports this protocol prior to downloading the application would solve this situation. Minidrivers are not required and are not supplied for some platforms. Minidrivers are optional and specific to each platform and when they are supplied can be found in the WICED Studio platforms subdirectories, for example “<Wiced-Studio-X.X>\20719-B0\_Bluetooth\platforms\CYW9207x9WCDEVAL\minidriver-20739A0-uart.hex”.

Note that the Vendor Specific HCI commands described in this section have address and length fields in little-endian byte order.

### 2.2 Preparing for HCI commands

When the device is initially powered on the boot code will attempt to identify the hardware interface to be used for HCI communication. For the case of UART, the device behavior depends on the state of CTS when RST\_N is de-asserted. If CTS is low at this time, then the device enters the autobaud state (download mode). If CTS is high after reset, then the device will check NVRAM and apply any stored configuration, typically ending in a mode ready to accept all HCI commands at a default baud rate. If no configuration is available, the device will also enter autobaud mode.

The autobaud mode will attempt to detect the UART baud rate by checking the RX line for the bit pattern of an HCI\_RESET command. When detected, the HCI\_RESET response is given at the same baud rate. In this mode most HCI commands will have no response. The HCI\_DOWNLOAD\_MINIDRIVER command, described in detail below, will also have no response when the device is in autobaud mode. To download to the device in this mode, ignore the “no response” to HCI\_DOWNLOAD\_MINIDRIVER and proceed with the download procedures as described below.

### 2.3 Download File Formats

Download images are kept in \*.hcd or \*.hex files. The \*.hcd is more typically used for RAM downloads and the \*.hex format is typically used for flash downloads. Each file format must be parsed and converted to HCI commands as described below to successfully transfer the image to the device. During download operations to reference boards controlled by WICED Studio, the ChipLoad application performs these operations.

The \*.hcd format consists of binary records that can be parsed and interpreted directly as HCI commands:

1. The first two binary bytes are the command identifier, for example for example, the HCI\_WRITE command described below is represented by binary bytes 0x4c, 0xfc
2. This following byte is the command payload length. For example, a binary 0x6 indicates that six more bytes to follow will complete the command.
3. The command payload follows, in binary bytes.

In order to convert the file successfully to HCI commands, only the transport indication needs to be added. For example, when using UART transport, the hex byte 0x1 should precede any HCI command to indicate that it is a command rather than an event. The detailed specifications for HCI transport are publicly available

The \*.hex format follows the Intel I32HEX conventions that are widely documented and can be found on Wikipedia, for example. The format consists of records delimited by ASCII carriage return and line feed (0xd, 0xa), but each record also has a start indicator, as described below.

1. Start code “:”, ASCII 0x3a
2. Byte count in record payload as two hexadecimal digits, for example ‘FF’ is a count of 255
3. Address as four hexadecimal digits, for example ‘1000’ would represent 0x1000 or 4096.
4. Record type as two hexadecimal digits. The record types used for download images are
  - a. ‘00’ for data record, where address field represents low 16-bits of image destination
  - b. ‘01’ for end of file (last record), the payload is zero bytes in length and the address field is not used and set as ‘0000’
  - c. ‘04’ for extended address (high 16 bits of subsequent data record addresses)
  - d. ‘05’ for a 32-bit address. The record address field is left at ‘0000’, the length is ‘04’ bytes, and the eight hexadecimal data digits are interpreted as a 32-bit address. For example ‘00220001’ would be the address 0x220001. This record is often used to indicate a LAUNCH\_RAM destination described below.
5. Record payload data represented as hexadecimal ASCII digits, two digits per byte and extending for the number of bytes indicated by the record’s byte count.
6. Checksum of the entire preceding record data represented as two hexadecimal ASCII digits.

When the \*.hex file is parsed, the data record payloads will resolve into one or more blocks of continuous data. When more than one block of data is present, there will be a discontinuity in the record addresses, The address gap may be described by a ‘04’ record, used to reset the upper 16-bits of address, followed by ‘00’ type data records forming the next block of data. Contiguous data blocks should be collected and segmented to form HCI WRITE\_RAM download command payloads as described below.

## 2.4 Downloading the Application to RAM

To download a target application to the CYW207xx device, perform the following steps:

1. Build the CYW207xx device target application using WICED Studio.  
To do this, double-click a client control capable application target in the Make Target pane. For example, double-click:  
**demo.ams-CYW920706WCDEVAL DIRECT\_LOAD=1 build**
2. In WICED Studio, navigate to the appropriate OS sub-folder under Apps/client\_control and launch the ClientControl application.
3. In the ClientControl application:
  - a. In the **<Select serial port>** menu, select the serial port associated with the CYW207xx evaluation board’s HCI UART.
  - b. Set the ClientControl baud rate to match the application baud rate, as configured by the application (see [Note below](#)). The ams application uses 3000000 baud rate by default.
  - c. Click **Browse** and select the (\*.hcd) file built earlier (in [Step 1 above](#)). The file will be located under WICED Studio SDK installation folder at a path similar to the following example for CYW20706:  
`<WICED-Studio-X.X>\20706-A2_Bluetooth\build\ams-CYW920706WCDEVAL-rom-ram-Wiced-release\ams-CYW920706WCDEVAL-rom-ram-Wiced-release.hcd.`

d. Click Download.

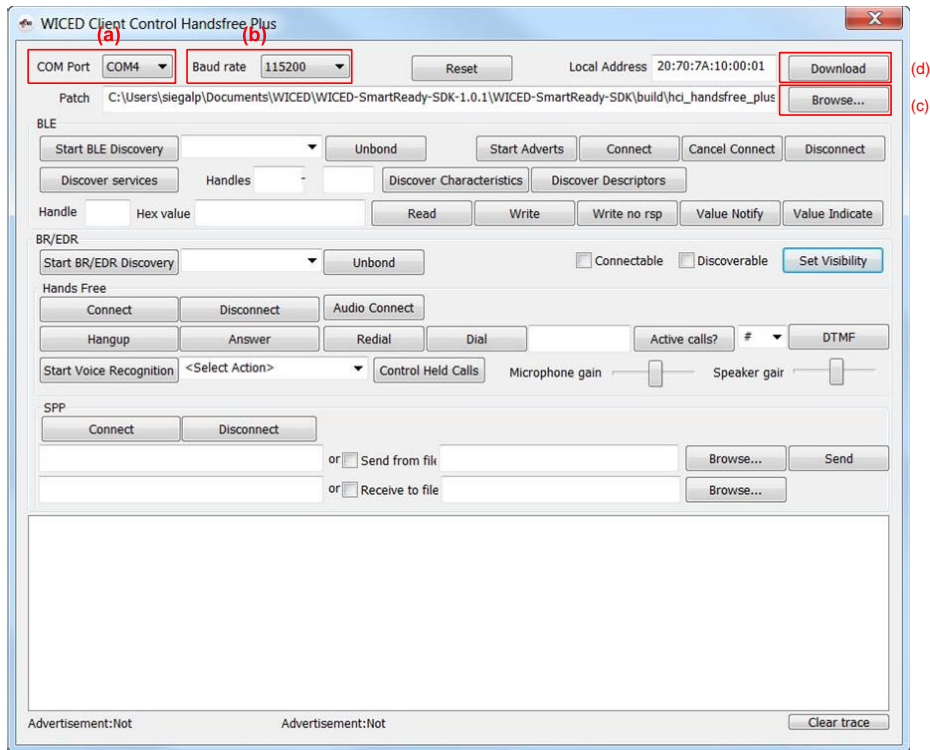

After clicking **Download**, messages similar to those shown in [Figure 2-1](#) will appear in the ClientControl console:

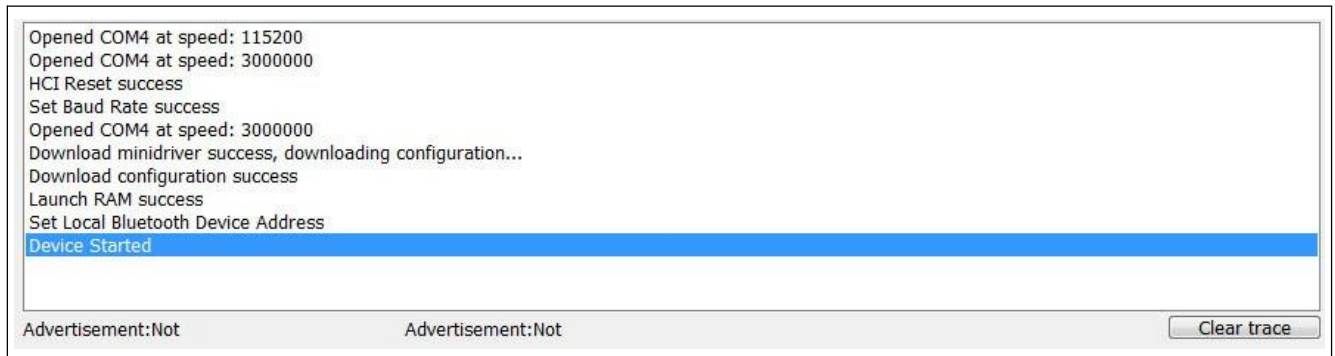

*Figure 2-1. ClientControl Console Showing Messages Following a Successful Download*

The commands as well as the responses and events behind the console messages shown in [Figure 2-1](#) are all conveyed using the Vendor Specific commands of the Bluetooth HCI protocol as defined in the Bluetooth Core specification [\[2\]](#).

Information on the console messages shown in [Figure 2-1](#) is provided in [HCI Commands and Events During a RAM Download](#).

### 2.4.1 HCI Commands and Events During a RAM Download

After a download is initiated (by clicking **Download** in the ClientControl application), host and controller messages are exchanged in the following sequence (which is represented by the console messages in [Figure 2-1](#)):

1. The PC (MCU) host issues the following standard Bluetooth HCI\_RESET command:

```
01 03 0C 00
```

The following response is expected from the CYW207xx device within 100 ms:

```
04 0E 04 01 03 0C 00
```

- To speed up application downloading, the MCU host commands the CYW207xx device to communicate at a new, higher rate by issuing the following Vendor Specific UPDATE\_BAUDRATE command:

```
01 18 FC 06 00 00 xx xx xx xx
```

In the above command, the xx xx xx xx bytes specify the 32-bit little-endian value of the new rate in bits per second. For example, 115200 is represented as 00 C2 01 00.

The following response to the UPDATE\_BAUDRATE command is expected within 100 ms:

```
04 0E 04 01 18 FC 00
```

- The host switches to the new baud rate after receiving the response at the old baud rate.
- If successful, the host issues the following DOWNLOAD\_MINIDRIVER Vendor Specific command:

```
01 2E FC 00
```

The following response is expected from the CYW207xx device within 100 ms:

```
04 0E 04 01 2E FC 00
```

If there is not response to the DOWNLOAD\_MINIDRIVER command, the device may be in autobaud mode (see section 2.2). While it is required to send the DOWNLOAD\_MINIDRIVER command, it is optional to download a minidriver itself. The ROM download code behavior is sufficient to perform the download for most cases. For these cases the download process continues directly to step 5 to download the application image.

If needed, the minidriver is loaded using WRITE\_RAM Vendor Specific commands, as described in step 5. The hex file format indicates the RAM address for each data chunk in the file. Data chunks from the file can be grouped up to the payload size of the WRITE\_RAM command. To start the minidriver, use a LAUNCH\_RAM command, as described in step 6, to begin minidriver execution at the first address of the minidriver image. For example, if the minidriver download starts at 0x220000, then the LAUNCH\_RAM command should use 0x220000 as the launch address. After launching the minidriver, continue the application download process with step 5.

- After optionally downloading the minidriver, the host writes application code and configuration data to the CYW207xx device by sending WRITE\_RAM Vendor Specific commands. Since the writes are destined for the CYW207xx device's RAM, the destination addresses in the WRITE\_RAM commands are absolute RAM locations.

The following WRITE\_RAM command is an example:

```
01 4C FC nn xx xx xx xx yy yy yy ...
```

In the above WRITE\_RAM command:

- nn is 4 + N, which represents 4 address bytes plus N payload bytes.
- xx xx xx xx is the 4-byte, absolute RAM address.
- yy yy yy ... are the N payload bytes to be loaded into the addressed RAM location.

The following response to each WRITE\_RAM command is expected within 200 ms:

```
04 0E 04 01 4C FC 00
```

- After the host has written all application and configuration data to RAM, it sends a LAUNCH\_RAM command with the address stored in the last record of the hardware configuration data (HCD) file.

An example LAUNCH\_RAM command is shown here:

```
01 4E FC 04 xx xx xx xx
```

In the above LAUNCH\_RAM command, xx xx xx xx is the 4-byte absolute RAM address of the last HCD record. Typically, the last address is 0xFFFFFFFF.

The following response to the LAUNCH\_RAM command is expected within 200 ms:

```
04 0E 04 01 4E FC 00
```

**Note:** Following a successful LAUNCH\_RAM command, the device is in the Application mode and the application is running.

**Note:** In the Application mode, the UART configuration depends on the application. If the application sets the baud rate to 3 Mbps at start-up then the MCU or ClientControl.exe running on a PC must also configure the UART for 3 Mbps operation to successfully communicate with the CYW207xx device. The application sets the baud rate using the following command:

uart\_SetBaudrate(0, 0, 300000). The default application baud rate is configured in the call to wiced\_transport\_init(). To set the UART rate via the host, see “Set Baud Rate”.

## 2.5 Downloading the Application to Serial Flash

To download a target application to the CYW207xx device, perform the following steps:

1. Build the CYW207xx device target application using WICED Studio.  
To do this, double-click a client control capable application target in the Make Target pane. For example, double-click: **demo.ams-CYW920706WCDEVAL\_download**
2. Once the application download image is built, the build process will attempt to download to the serial port associated with the CYW207xx evaluation board's HCI UART:

- a. If the serial port is not already identified, the build process searches available ports for the target device at several baud rates. If the device does not respond to HCI commands at this time the download process will fail. A manual board reset or recovery procedure may be needed to restore the board to Bluetooth HCI mode. See the Kit Guide [1] for your device for recovery procedure information.
- b. Once the port is identified, the build process begins the download procedure with an image file located under the WICED Studio installation folder at a path similar to the following for CYW20706:

```
<WICED-Studio-X.X>\20706-A2_Bluetooth\build\ams-CYW920706WCDEVAL-rom-ram-Wiced-release\ams-CYW920706WCDEVAL-rom-ram-Wiced-release.hex
```

Note that the hex file format consists of records that include data and address information. For serial flash download hex files, the addresses used map to offsets in the flash device. For example, CYW20706 and CYW20735 hex records map the address 0xFF000000 to the base, or 0, offset in the attached serial flash device. Similarly, the CYW20719 uses 0x00500000 as the base address for the on chip flash.

Note that the Vendor Specific HCI commands READ\_RAM, WRITE\_RAM, and LAUNCH\_RAM are not limited to actual RAM address ranges. The same commands are used to write to non-volatile storage like serial flash by using mapped addresses that correspond to offsets within these devices.

## 2.6 HCI Commands and Events During a Serial Flash Download

This section describes the protocol for the download process described above for the situations when an MCU needs to load the image to the serial flash attached to the CYW207xx device.

During the download process the host and controller exchange messages in the following sequence:

1. The PC (MCU) host issues the following standard Bluetooth HCI\_RESET command:

```
01 03 0C 00
```

The following response is expected from the CYW207xx device within 100 ms:

```
04 0E 04 01 03 0C 00
```

2. To speed up application downloading, the MCU host commands the CYW207xx device to communicate at a new, higher rate by issuing the following Vendor Specific UPDATE\_BAUDRATE command:

```
01 18 FC 06 00 00 xx xx xx xx
```

In the above command, the xx xx xx xx bytes specify the 32-bit value of the new rate in bits per second. For example, 115200 is represented as 00 C2 01 00.

The following response to the UPDATE\_BAUDRATE command is expected within 100 ms:

```
04 0E 04 01 18 FC 00
```

3. The host switches to the new baud rate after receiving the response at the old baud rate.
4. If successful, the host issues the following DOWNLOAD\_MINIDRIVER command:

```
01 2E FC 00
```

The following response is expected from the CYW207xx device within 100 ms:

```
04 0E 04 01 2E FC 00
```



If there is not response to the `DOWNLOAD_MINIDRIVER` command, the device may be in autobaud mode (see section 2.2). While it is required to send the `DOWNLOAD_MINIDRIVER` command, it is optional to download a minidriver itself. The ROM download code behavior is sufficient to perform the download for most cases. For these cases the download process continues directly to step 5 to download the application image.

If needed, the minidriver is loaded using `WRITE_RAM` Vendor Specific commands, as described in step 5. The hex file format indicates the RAM address for each data chunk in the file. Data chunks from the file can be grouped up to the payload size of the `WRITE_RAM` command. To start the minidriver, use a `LAUNCH_RAM` command, as described in step 7, to begin minidriver execution at the first address of the minidriver image. For example, if the minidriver download starts at 0x220000, then the `LAUNCH_RAM` command should use 0x220000 as the launch address. After launching the minidriver, continue the application download process with step 5.

5. After optionally downloading the mini-driver, the host writes application code and configuration data to the CYW207xx device by sending `WRITE_RAM` commands.

The following `WRITE_RAM` command is an example:

```
01 4C FC nn xx xx xx xx yy yy yy ...
```

In the above `WRITE_RAM` command:

- a. `nn` is  $4 + N$ , which represents 4 address bytes plus  $N$  payload bytes.
- b. `xx xx xx xx` is the 4-byte, mapped address for serial flash offset.
- c. `yy yy yy ...` are the  $N$  payload bytes to be loaded into the mapped address. The following response to each `WRITE_RAM` command is expected within 200 ms:

```
04 0E 04 01 4C FC 00
```

6. After the host has written application and configuration data to flash, it can be validated with a CRC check command. Also, any block can be read back using the `READ_RAM` command.

- a. CRC method: return the CRC-32 calculated by reading the data range indicated in the command. The following CRC validation command is an example:

```
01 CC FC 08 xx xx xx xx yy yy yy yy
```

In the above command, the `xx xx xx xx` bytes specify the 32-bit value of the mapped address for the serial flash offset and the `yy yy yy yy` bytes specify the 32-bit value of the number of bytes to be read from the serial flash for the CRC calculation.

The following response is expected after the `READ_RAM` command:

```
04 0E 08 01 CC FC 00 xx xx xx xx
```

In the above response, the `xx` bytes are the 32-bit CRC-32 value calculated by reading the data bytes from flash starting at the virtual address given in the CRC command and continuing for the number of bytes provided in the CRC command.

- b. The following `READ_RAM` command is an example:

```
01 4D FC 05 xx xx xx xx yy
```

In the above command, the `xx xx xx xx` bytes specify the value of the serial flash offset's mapped address and the `yy` byte specifies the length of data to be read.

The following response is expected within 100 milliseconds of the `READ_RAM` command:

```
04 0E xx 01 4D FC 00 yy yy yy ...
```

In the above response, the `xx` byte represents  $N+4$ , where  $N$  is the number of data bytes read from the flash. The `yy` bytes are the actual data read back from the mapped offset.

7. After the host has written and validated all application and configuration data to RAM, it sends a `LAUNCH_RAM` command with the special destination address specifying reboot for the device, typically 0xFFFFFFFF.

An example `LAUNCH_RAM` command is shown here:

```
01 4E FC 04 xx xx xx xx
```

In the above command, the `xx xx xx xx` bytes represent the destination address for the CPU branch.

The following response to the `LAUNCH_RAM` command is expected within 200 ms:

```
04 0E 04 01 4E FC 00
```

### 3 WICED HCI Control Protocol Definition

The CYW207xx uses the following 5-byte packet header for command/event exchanges with the host MCU.

Packet Type	Command/ Event Code	Group Code	Packet Length	
HCI_WICED_PKT(0x19)	HCI_CONTROL_COMMAND_...	HCI_CONTROL_GROUP_...	Low byte	High byte

The protocol follows the standard Bluetooth HCI rules for parameter byte ordering. For example, the attribute handle 0x210 is sent in two bytes, 0x10 followed by 0x02.

All commands and events are split into groups. [Table 3-1](#) shows the groups defined by the WICED HCI Control Protocol.

Group Name	Group Value	Description
HCI_CONTROL_GROUP_DEVICE	0x00	General control of CYW207xx management and Bluetooth functionality
HCI_CONTROL_GROUP_LE	0x01	LE device-related commands and events
HCI_CONTROL_GROUP_GATT	0x02	GATT commands and events
HCI_CONTROL_GROUP_HF	0x03	Hands-free profile commands, events, and data
HCI_CONTROL_GROUP_SPP	0x04	Serial port profile commands, events, and data
HCI_CONTROL_GROUP_AUDIO	0x05	Audio/video (AV) commands, events, and data
HCI_CONTROL_GROUP_HIDD	0x06	HID device (HIDD) commands and events
HCI_CONTROL_GROUP_AVRC_TARGET	0x07	AV remote control (AVRC) target commands and events
HCI_CONTROL_GROUP_TEST	0x08	Test commands
HCI_CONTROL_GROUP_TIME	0x0A	Current time client application events
HCI_CONTROL_GROUP_ANCS	0x0B	Apple Notification Center Service (ANCS) commands and events
HCI_CONTROL_GROUP_ALERT	0x0C	Immediate Alert Service (IAS) events
HCI_CONTROL_GROUP_LN	0x0D	Location and navigation commands and events.
HCI_CONTROL_GROUP_IAP2	0x0E	iPod Accessory Protocol implementation (iAP2) commands and events
HCI_CONTROL_GROUP_AG	0x0F	Hands-free Audio Gateway (AG) commands and events
HCI_CONTROL_GROUP_AIO_SERVER	0x10	Automation IO (AIO) server commands and events
HCI_CONTROL_GROUP_AIO_CLIENT	0x10	AIO client commands and events
HCI_CONTROL_GROUP_AVRC_CONTROLL	0x11	AV remote control (AVRC) controller commands and events
HCI_CONTROL_GROUP_AMS	0x12	Apple Media Service (AMS) commands and events
HCI_CONTROL_GROUP_AUDIO_SINK	0x14	Audio sink commands, events and data
HCI_CONTROL_GROUP_MISC	0xFF	Miscellaneous commands and events

Table 3-1. WICED HCI Control Protocol Command and Event Groups

See [“WICED HCI Control Protocol Commands”](#) for information on the WICED HCI Control Protocol commands.

See [“WICED HCI Control Protocol Events”](#) for information on the WICED HCI Control Protocol events.



## 4 WICED HCI Control Protocol Commands

### 4.1 Device Commands: HCI\_CONTROL\_GROUP\_DEVICE

The device commands allow the host to manage the behavior of the CYW207xx.

#### 4.1.1 Reset

The Reset command causes the CYW207xx to restart. After initialization completes, the CYW207xx sends a Device Started event (see “[Device Started](#)”).

Item	Description
Operating code	0x01
Parameters	–

Table 4-1. Reset Command

#### 4.1.2 Trace Enable

The Trace Enable command instructs the CYW207xx to start or stop forwarding the WICED logs and virtual HCI traces.

The CYW207xx provides the following two trace types:

- An output of the WICED\_BT\_TRACE statements.
- A binary dump of the virtual HCI commands, events, and data packets between the embedded host stack and the CYW207xx controller.

The WICED\_BT\_TRACE output is forwarded in the HCI\_CONTROL\_EVENT\_WICED\_TRACE when a corresponding trace is enabled.

The virtual HCI traces are sent over UART using HCI\_CONTROL\_EVENT\_HCI\_DATA.

Item	Description	
Operating code	0x02	
Parameters	Bluetooth HCI trace enable (1 byte)	If true, HCI traces are routed through the WICED HCI interface to the host.
	WICED trace route (1 byte)	0: Traces are not generated. 1: Traces are forwarded to the WICED UART. 2: Traces are forwarded to the HCI UART. 3: Traces are forwarded to the debug UART. 4: Traces are forwarded to the peripheral UART.

Table 4-2. Trace Enable Command

### 4.1.3 Set Local Bluetooth Device Address

The Set Local Bluetooth Device Address command configures the CYW207xx to use a new Bluetooth device address. An MCU host typically sends this command during a start-up operation. The address is passed as a parameter in little-endian format.

Item	Description
Operating code	0x03
Parameters	A 6-byte Bluetooth device address

Table 4-3. Set Local Bluetooth Device Address Command

### 4.1.4 Set Baud Rate

The Set Baud Rate command instructs the CYW207xx to use a new baud rate for UART communications. An MCU may send this command during a start-up operation. It might not be needed if the MCU knows that the application on the CYW207xx sets a specific baud rate during start-up.

Item	Description	
Operating code	0x04	
Parameters	New baud rate (4 bytes)	As all other parameters in the HCI Control Protocol, the parameter is passed in little endian order. Example: To set a baud rate of 3 Mbps, send 0x2DC6C0 (3,000,000) as the following four-byte sequence: 0xC0 0xC6 0x2D 0x00.

Table 4-4. Set Baud Rate Command

### 4.1.5 Push NVRAM Data

If a CYW207xx does not have an embedded NVRAM, it relies on the MCU to save application-specific NVRAM data, which the CYW207xx can provide in NVRAM Data events (see “NVRAM Data”). At start-up, the MCU host should push all saved NVRAM information to the CYW207xx before the CYW207xx establishes any Bluetooth connections.

Item	Description	
Operating code	0x05	
Parameters	nvrām_id (2 bytes)	ID of an NVRAM information chunk
	nvrām_data (variable bytes)	Data corresponding to nvrām_id

Table 4-5. Push NVRAM Data Command

### 4.1.6 Delete NVRAM Data

An application running on an MCU host may request the CYW207xx to delete NVRAM information for a specific nvrām\_id.

Item	Description	
Operating code	0x06	
Parameters	nvrām_id	2-byte ID of an NVRAM information chunk

Table 4-6. Delete NVRAM Data Command

### 4.1.7 Inquiry

The Inquiry command lets an application cancel or start a Bluetooth Inquiry procedure.

If a device is found during an inquiry, the CYW207xx sends an Inquiry Result event (see [“Inquiry Result”](#)).

When an Inquiry procedure completes, the CYW207xx sends an Inquiry Complete Event (see [“Inquiry Complete”](#)).

Item	Description	
Operating code	0x07	
Parameters	Enable (1 byte)	0: Cancel the Inquiry procedure.
		1: Start an Inquiry procedure.

Table 4-7. Inquiry Command

### 4.1.8 Set Visibility

The Set Visibility command allows the host to turn Discoverability and Connectability on and off. After a CYW207xx restart, it is not discoverable (non-discoverable) and not connectable (non-connectable).

**Note:** Attempts to make the CYW207xx discoverable and non-connectable will be rejected because, according to the Bluetooth specifications, a discoverable device should also be connectable.

After the CYW207xx receives this command, it reports command success or failure in the Command Status event (see [“Command Status”](#)).

Item	Description	
Operating code	0x08	
Parameters	Discoverability (1 byte)	0: Not discoverable
		1: Discoverable
	Connectability (1 byte)	0: Not connectable
		1: Connectable

Table 4-8. Set Visibility Command

### 4.1.9 Set Pairing Mode

The MCU can set the CYW207xx to be pairable or not pairable using this command. A BR/EDR connection will be rejected if a device is not pairable and there is no link key to secure the connection. Similarly, while a device is not pairable, access to LE characteristics requiring security will fail. While pairable, a pairing attempt from a peer device will be accepted.

After the CYW207xx receives this command, it reports command success or failure in the Command Status event (see [“Command Status”](#)).

Item	Description	
Operating code	0x09	
Parameters	Pairing mode (1 byte)	0: Not pairable
		1: Pairable

Table 4-9. Set Pairing Mode Command

#### 4.1.10 Unbond

The MCU can use this command to instruct the CYW207xx to remove bonding information (that is, security keys) for the device whose Bluetooth device address is passed as a parameter.

After the CYW207xx receives this command, it reports command success or failure in the Command Status event (see “[Command Status](#)”).

Item	Description	
Operating code	0x0A	
Parameters	Address (6 bytes)	Bluetooth device address

Table 4-10. Unbond Command

#### 4.1.11 User Confirmation

The MCU should send this command after it receives a User Confirmation Request event (see “[User Confirmation Request](#)”) from the CYW207xx to accept or reject pairing. It is assumed that an MCU will display the numeric comparison code provided in the User Confirmation Request event and a user will provide the yes/no input that will be passed to the CYW207xx as the User Confirmation command.

Item	Description	
Operating code	0x0B	
Parameters	Address (6 bytes)	Bluetooth device address
	Accept/Reject (1 byte)	0: Reject pairing, or the numeric comparison code does not match. 1: Accept pairing

Table 4-11. User Confirmation Command

#### 4.1.12 Enable Coexistence

This command allows an MCU to enable the coexistence functionality in designs that include BT/BLE and WiFi applications.

Item	Description
Operating code	0x0C
Parameters	–

Table 4-12. Enable Coexistence Command

#### 4.1.13 Disable Coexistence

This command allows an MCU to disable the coexistence functionality in designs that include BT/BLE and WiFi applications.

Item	Description
Operating code	0x0D
Parameters	–

Table 4-13. Disable Coexistence Command

#### 4.1.14 Set Battery Level

This miscellaneous command allows the MCU to set the battery level in the GATT database of the CYW207xx. A connected peer device can read the battery level using a standard ATT read operation.

Item	Description
Operating code	0x0E
Parameters	Battery level (1 byte) Remaining battery capacity as a percentage (1 to 100).

Table 4-14. Set Battery Level Command

#### 4.1.15 Read Local Bluetooth Device Address

The MCU can send this command to read the local Bluetooth Device Address of the CYW207xx. When the CYW207xx receives this command it responds with the Read Local BDA Event message containing the Bluetooth Device Address.

Item	Description
Operating code	0x0F
Parameters	-

Table 4-15. Read Local Bluetooth Device Address Command

#### 4.1.16 Start Bond

The MCU can send this command to initiate bonding with an unbonded device.

Item	Description	
Operating code	0x10	
Parameters	Address (6 bytes)	
	Transport (1 byte)	1 = BR/EDR, 2 = LE
	Address Type (1 bytes)	0 = Public, 1 = Random (LE Only)

Table 4-16. Start Bond Command

#### 4.1.17 Read Buffer Pool Usage Statistics

The MCU can send this command to read the buffer pool usage statistics to understand the buffer pool usage by the application running on the CYW207xx, and to identify if there is a possibility of buffers running out for a given application use case. The Buffer Pool Usage Statistics event will be sent from the CYW207xx to the MCU which includes the buffer pool usage statistics.

Item	Description
Operating code	0x11
Parameters	-

Table 4-17. Read Buffer Pool Usage Statistics Command

## 4.2 LE Commands: HCI\_CONTROL\_GROUP\_LE

The LE commands let the MCU perform various LE Generic Access Profile (GAP) procedures using the CYW207xx.

### 4.2.1 LE Scan

The LE Scan command instructs the CYW207xx to start or stop device discovery. The scan mode, window, interval, and duration are configured locally in the application running on the CYW207xx (see the `wiced_bt_cfg.c` file in WICED Studio). When the device starts scanning, it executes a high- duty-cycle scan where it listens for advertisements during programmed windows occurring at programmed intervals for a programmed duration. Unless canceled by the application, the device then automatically switches to a low-duty-cycle scan. The device stops scanning after the low-duty-cycle scan duration.

Figure 4-1 shows an advertisement scanning cycle.

Figure 4-1. Advertisement Scanning

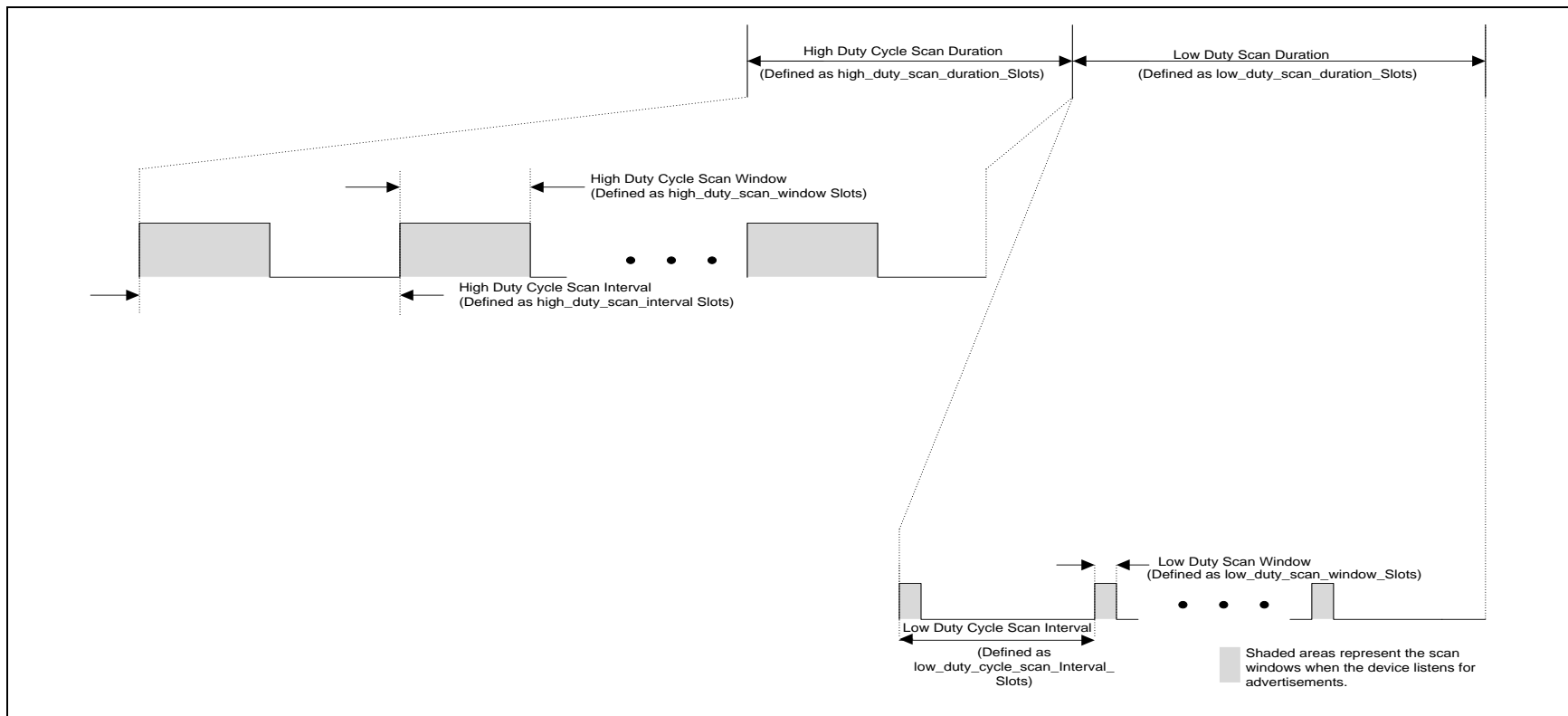

When the CYW207xx receives and processes this command, it reports the scan state change in the Scan Status event (see “LE Scan Status”). Scan Status events are also sent when the CYW207xx switches from a high-duty-cycle scan to a low-duty-cycle scan and from a low-duty-cycle scan to not scanning.

Item	Description	
Operating code	0x01	
Parameters	Enable (1 byte)	0: Stop device-discovery scanning. 1: Start device-discovery scanning.
	Filter duplicates (1 byte)	0: Do not filter duplicate advertisements. 1: Filter duplicate advertisements.

Table 4-18. LE Scan Command

## 4.2.2 LE Advertise

The LE Advertise command instructs the CYW207xx to stop or start sending advertisements. Typically, advertisements are sent so that a central-device peer can discover and optionally connect to a peripheral-device peer. When a CYW207xx receives this command, it sends advertisements based on parameters configured in the `wiced_bt_cfg_ble_advert_settings_t` structure of the `wiced_bt_cfg_settings_t` structure (which is in the `wiced_bt_cfg.c` file of WICED Studio).

Initially, advertisements are sent out using a programmed high-duty-cycle advertisement profile. After the high-duty-cycle duration (for example, `high_duty_duration`) expires, advertisements are sent out in accordance with a programmed low-duty-cycle advertisement profile, which also has a duration (for example, `low_duty_duration`). After the `low_duty_duration`, the CYW207xx stops sending advertisements.

Figure 4-2 shows the high-duty-cycle and low-duty-cycle advertisement-sending profiles.

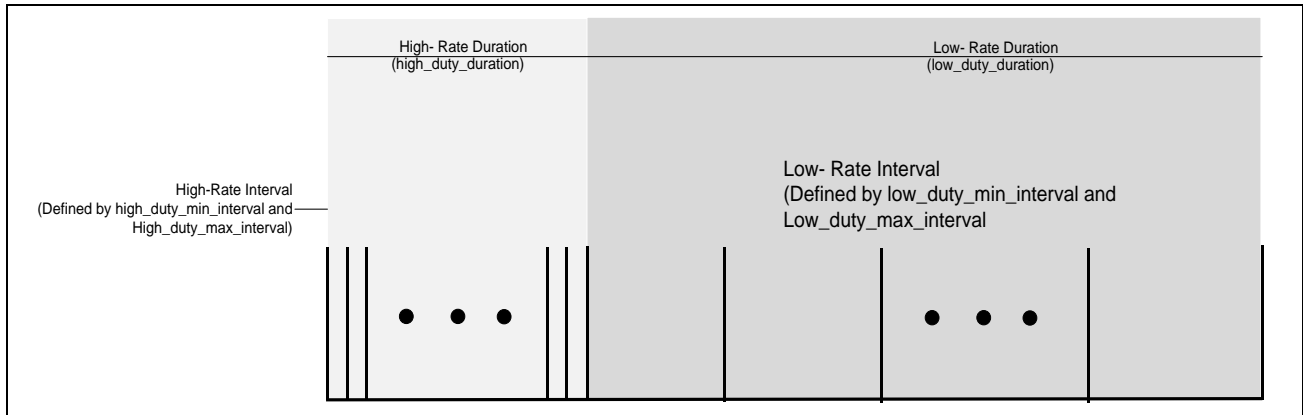

Figure 4-2. Advertisement-Sending Profile

When the CYW207xx receives and processes this command, it reports advertisement state changes in the Advertisement State event (see “LE Advertisement State”). Advertisement State events are also sent when the CYW207xx controller switches from the high-duty-cycle advertisements to low-duty-cycle advertisements and from low-duty-cycle advertisements to no advertisements.

Item	Description	
Operating code	0x02	
Parameters	Enable (1 byte)	0: Disable the ability to be discovered (that is, don't send advertisements). 1: Enable the ability to be discovered (that is, send advertisements).

Table 4-19. LE Advertise Command

### 4.2.3 LE Connect

The LE Connect command instructs the CYW207xx to try establishing a connection to a specified peer device.

When the CYW207xx receives and processes this command, it reports status back in the Command Status event (see “[Command Status](#)”).

When a connection is established, the CYW207xx sends a Connected event (see “[LE Connected](#)”).

Item	Description
Operating code	0x03
Parameters	Address type (1 byte)
	Device address (6 bytes)

Table 4-20. LE Connect Command

### 4.2.4 LE Cancel Connect

The LE Cancel Connect command instructs the CYW207xx to stop a connection-establishment attempt.

When the CYW207xx receives and processes this command, it reports No Scan in the Scan Status event (see “[LE Scan Status](#)”).

Item	Description
Operating code	0x04
Parameters	–

Table 4-21. LE Cancel Connect Command

### 4.2.5 LE Disconnect

The LE Disconnect command terminates a previously established Bluetooth LE connection. The connection handle is a two-byte value reported in the LE Connected event (see “[LE Connected](#)”), which gets sent by the CYW207xx upon a successful connection.

When the CYW207xx receives and processes this command, it takes one of the following actions:

- If the connection does not exist, it reports Not Connected in the Command Status event (see “[Command Status](#)”).
- If the connections exists:
  - It reports Success in the Command Status event.
  - It starts the disconnection process.
  - It reports the Disconnected event when the disconnection process finishes.

Item	Description
Operating code	0x05
Parameters	Connection handle (2 bytes)

Table 4-22. LE Disconnect Command



#### 4.2.6 LE Re Pair

This command instructs the CYW207xx to delete link keys associated with a previously paired device and re-initiate a pairing sequence with that same device.

The NVRAM ID parameter should match the value reported to the MCU after the successful pairing in the NVRAM Data event (see “[NVRAM Data](#)”).

Item	Description	
Operating code	0x06	
Parameters	NVRAM ID (2 bytes)	ID associated with the address of the device from the original pairing.

Table 4-23. LE Re Pair Command

#### 4.2.7 LE Get Identity Address

When an initial connection with a peer is established, the MCU will receive a private random address (if a private random address is used) of the device in the LE Connection Up event message. The LE Get Identity Address command can be used by the MCU to retrieve the Identity Address, which is a public or a static random address of the peer device.

If an MCU attempts to retrieve the resolved identity address of the peer, then this command can be used. The resolved identity address of the peer will be returned in the LE Identity Address event message (see “[LE Identity Address](#)”).

Item	Description	
Operating code	0x07	
Parameters	Device address (6 bytes)	Address of the peer device

Table 4-24. LE Get Identity Address Command

#### 4.2.8 LE Set Channel Classification

The MCU can send this command to the CYW207xx and set the channel classification for data channels. This channel classification is only applicable to connections where the CYW207xx is the master. This command contains 37 1-bit fields which correlate to the value for the link layer channel index 0 - 36.

Item	Description	
Operating code	0x08	
Parameters	BLE Channel Map (5 bytes)	This parameter contains 37 1-bit fields for the link layer channel indexes 0 -36. Channel n is bad = 0 Channel n is unknown = 1 At least one channel should be marked as unknown.

Table 4-25. LE Set Channel Classification Command

## 4.2.9 LE Set Connection Parameters

The MCU can send this command to the CYW207xx and change the connection parameters (interval min/max, latency and timeout) of an LE link.

Item	Description	
Operating code	0x09	
Parameters	Connection handle (2 bytes)	
	Connection Interval Minimum (2 bytes)	Time = N * 1.25 ms
	Connection Interval Maximum (2 bytes)	Time = N * 1.25 ms
	Slave Latency (2 bytes)	In number of connection event
	Timeout (2 bytes)	Time = N * 10 ms

Table 4-26. LE Set Connection Parameters Command

## 4.3 GATT Commands: HCI\_CONTROL\_GROUP\_GATT

The GATT commands let an MCU perform various Generic Attribute Profile (GATT) procedures using the CYW207xx.

### 4.3.1 GATT Discover Services

The GATT Discover Services command enables service discovery over an established Bluetooth LE connection. The connection handle is a two-byte value reported in the LE Connected event (see [“LE Connected”](#)).

The hci\_control application uses the Discover All Primary Services GATT procedure. The start and end handles are passed to the GATT Read By Group Type Request.

When the CYW207xx receives and processes this command, it takes one of the following actions:

- If the connection does not exist or the device is busy performing another action, such as discovery, reading, writing, etc., then it reports the relevant status in the Command Status event (see [“Command Status”](#)).
- If the connection exists and the device is not busy performing another action, then it reports Success in the Command Status event and starts the discovery process.

The CYW207xx sends a GATT Service Discovered event (see [“GATT Service Discovered”](#)) for each discovered service. When a peer reports that there are no more services, the GATT Discovery Complete event (see [“GATT Discovery Complete”](#)) is issued. The MCU should not send any new discovery, read, or write commands until after receiving the GATT Discovery Complete event.

Item	Description
Operating code	0x01
Parameters	Connection handle (2 bytes)
	Start handle (2 bytes)
	End handle (2 bytes)

Table 4-27. GATT Discover Services Command

### 4.3.2 GATT Discover Characteristics

The GATT Discover Characteristics command enables characteristic discovery over an established Bluetooth LE connection. The connection handle is a two-byte value reported in the LE Connected event (see “LE Connected”).

The hci\_control application uses the Discover All Characteristics of a service GATT procedure. The start and end handles are passed to the GATT Read By Type Request.

When the CYW207xx receives and processes this command, it takes one of the following actions:

- If the connection does not exist or the device is busy performing another action, such as discovery, reading, writing, etc., then it reports the relevant status in the Command Status event (see “Command Status”).
- If the connection exists and the device is not busy performing another action, then it reports Success in the Command Status event and starts the discovery process.

The CYW207xx reports a GATT Characteristic Discovered event (see “GATT Characteristic Discovered”) for each discovered characteristic. When a peer reports that there are no more characteristics, the GATT Discovery Complete event (see “GATT Discovery Complete”) is issued. The MCU should not send any new discovery, read, or write commands until after receiving the GATT Discovery Complete event.

Item	Description
Operating code	0x02
Parameters	Connection handle (2 bytes)
	Start handle (2 bytes)
	End handle (2 bytes)

Table 4-28. GATT Discover Characteristics Command

### 4.3.3 GATT Discover Descriptors

The GATT Discover Descriptors command enables characteristic-descriptors discovery over an established Bluetooth LE connection. The connection handle is a two-byte value reported in the LE Connected event (see “LE Connected”).

The hci\_control application uses the Discover All Characteristic Descriptors GATT procedure. The start and end handles are passed to the Find Info Request.

When the CYW207xx receives and processes this command, it takes one of the following actions:

- If the connection does not exist or the device is busy performing another action, such as discovery, reading, writing, etc., then it reports the relevant status in the Command Status event (see “Command Status”).
- If the connection exists and the device is not busy performing another action, then it reports Success in the Command Status event and starts the discovery process.

The CYW207xx reports a GATT Descriptor Discovered event (see “GATT Descriptor Discovered”) for each discovered characteristic descriptor. When a peer reports that there are no more descriptors, the CYW207xx sends a GATT Discovery Complete event (see “GATT Discovery Complete”). The MCU should not send any new discovery, read, or write commands until after receiving the GATT Discovery Complete event.

Item	Description
Operating code	0x03
Parameters	Connection handle (2 bytes)
	Start handle (2 bytes)
	End handle (2 bytes)

Table 4-29. GATT Discover Descriptors Command

### 4.3.4 GATT Command Read Request

The GATT Command Read Request command enables MCU reading of a characteristic value or a descriptor value over an established Bluetooth LE connection. The connection handle is a two-byte value reported in the LE Connected event (see “LE Connected”).

When the CYW207xx receives and processes this command, it takes one of the following actions:

- If the connection does not exist or the device is busy performing another action, such as discovery, reading, writing, etc., then it reports the relevant status in the Command Status event (see “Command Status”).
- If the connection exists and the device is not busy performing another action, then it reports Success in the Command Status event and starts the read process.

When a GATT Command Read Request is received over the UART, the hci\_control application sends the Read Request for the attribute handle received in the command.

Figure 4-3 shows an example message sequence that takes place when one device (represented as the combination of MCU1 and BT1) requests a static attribute such as the BT device name from a second device (represented as the combination of MCU2 and BT2). In this scenario, BT2 has the attribute value and returns it.

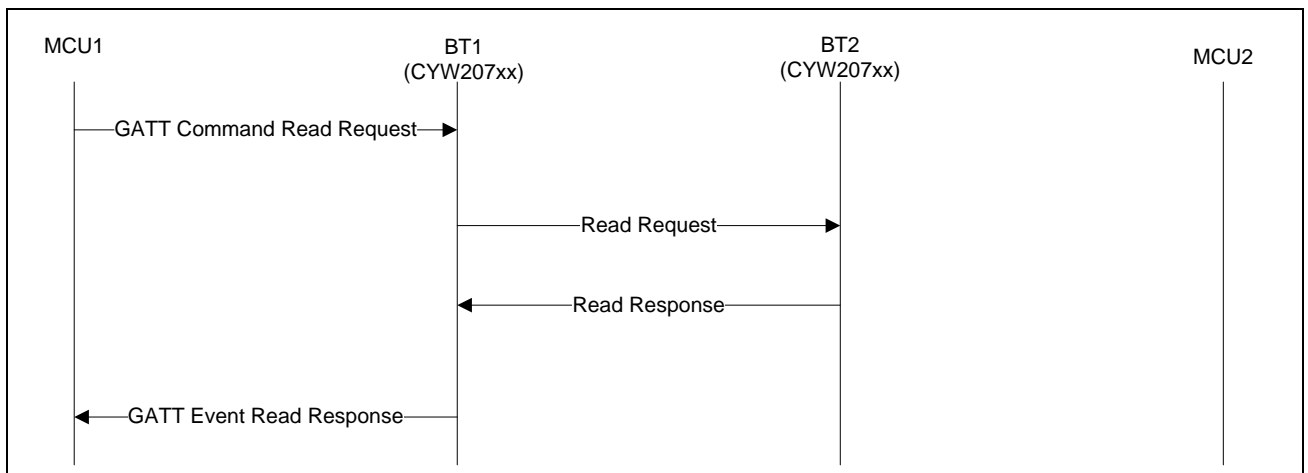

Figure 4-3. Reading a Static Attribute from a Peer

Figure 4-4 shows an example where BT2 must get an attribute value from MCU2.

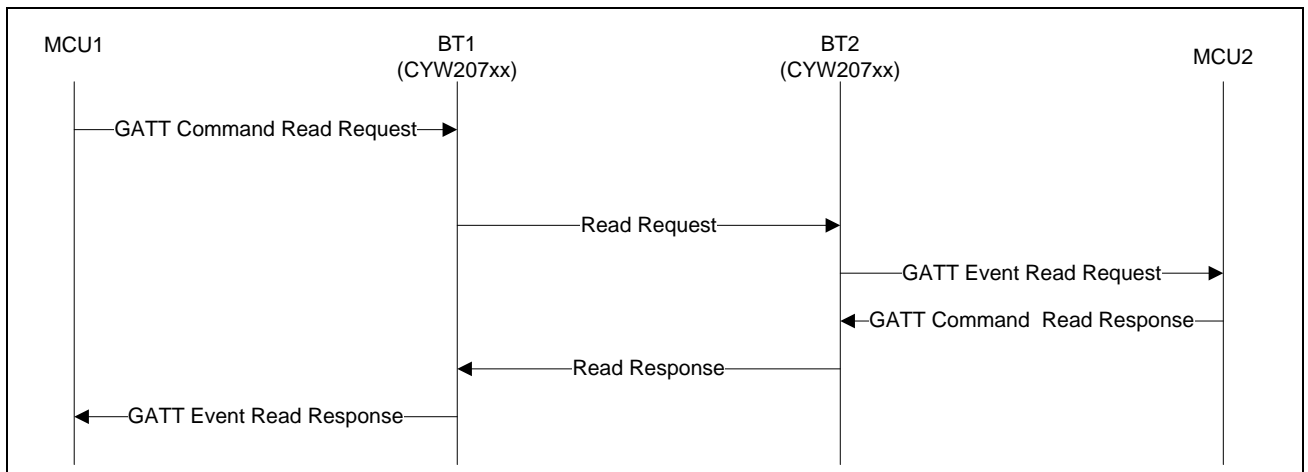

Figure 4-4. Reading a Dynamic Attribute from a Peer

When a GATT Read Response or a GATT Error Response is received over the Bluetooth link, the hci\_control application sends the GATT Event Read Response (see “[GATT Event Read Response](#)”). The MCU should not send any new discovery, read, or write commands until after receiving the GATT Event Read Response.

Item	Description
Operating code	0x04
Parameters	Connection handle (2 bytes)
	Attribute handle (2 bytes)

Table 4-30. GATT Command Read Request

### 4.3.5 GATT Command Read Response

The GATT Command Read Response is sent by an MCU in response to a GATT Event Read Request (see [Figure 4-4 in GATT Command Read Request](#)). The connection and attribute handles are the same 2- byte values that were sent in the GATT Event Read Request.

When the CYW207xx receives and processes this command, it takes one of the following actions:

- If the connection does not exist, then it reports the relevant status in the Command Status event (see “[Command Status](#)”).
- If the connection exists, then it reports Success in the Command Status event and sends the response to the connected Bluetooth device.

Item	Description
Operating code	0x05
Parameters	Connection handle (2 bytes)
	Attribute handle (2 bytes)
	Read Status (1 byte)
	Data (variable bytes)

Table 4-31. GATT Command Read Response

### 4.3.6 GATT Command Write

The GATT Command Write command enables MCU scheduling of transmissions over an established Bluetooth LE connection. The connection handle is a two-byte value reported in the LE Connected event (see “LE Connected”).

When the CYW207xx receives and processes this command, it takes one of the following actions:

- If the connection does not exist or the device is busy performing another action, such as discovery, reading, writing, etc., then it reports the relevant status in the Command Status event (see “Command Status”).
- If the connection exists and the device is not busy performing another action, then it reports Success in the Command Status event and starts the write process.

The CYW207xx has a limited number of transmit buffers. If the hci\_control application is able to allocate a buffer and schedule it for transmission, then the write operation is considered complete and the hci\_control application sends the GATT Event Write Response (see “GATT Event Write Response”). If all transmit buffers are already allocated and, thus, unavailable, then the hci\_control application saves the data received in the command and delays sending the GATT Event Write Response until a transmit buffer becomes available and the data gets scheduled for transmission. The MCU should not send any new discovery, read, or write commands until after receiving the GATT Event Write Response.

Item	Description
Operating code	0x06
Parameters	Connection handle (2 bytes)
	Attribute handle (2 bytes)
	Data (variable bytes)

Table 4-32. GATT Command Write Command

Figure 4-5 shows an example GATT Command Write message sequence.

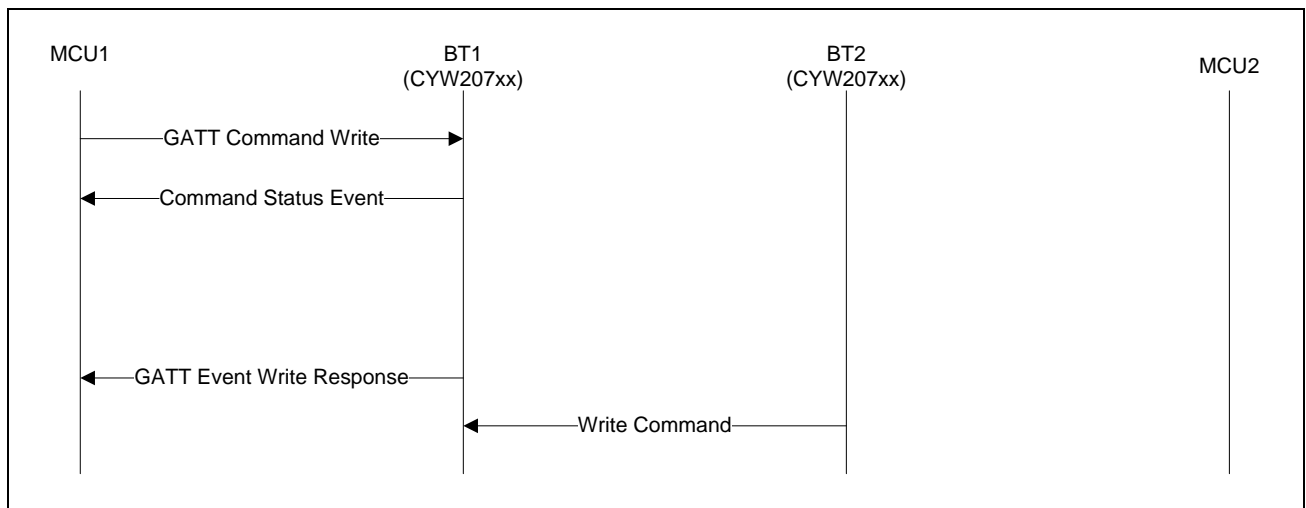

Figure 4-5. GATT Command Write message sequence

### 4.3.7 GATT Command Write Request

The GATT Command Write Request enables MCU writing of a characteristic value or a descriptor value over an established Bluetooth LE connection. The connection handle is a two-byte value reported in the LE Connected event (see "LE Connected").

When the CYW207xx receives and processes this command, it takes one of the following actions:

- If the connection does not exist or the device is busy performing another action, such as discovery, reading, writing, etc., then it reports the relevant status in the Command Status event (see "Command Status").
- If the connection exists and the device is not busy performing another action, then it reports Success in the Command Status event and starts the write process.

When the command is received over the UART, the hci\_control application sends a GATT Write Request for the attribute handle received in the command. When a GATT Write Response or a GATT Error Response is received from a connected peer device, the hci\_control application sends the GATT Event Write Response (see "GATT Event Write Response") to a connected MCU. The MCU should not send any new discovery, read, or write commands until after receiving the GATT Write Completed event.

Item	Description
Operating code	0x07
Parameters	Connection handle (2 bytes)
	Attribute handle (2 bytes)
	Data (variable bytes)

Table 4-33. GATT Command Write Request

Figure 4-6 shows a GATT Command Write Request sequence where the peer device does not require involvement from its MCU.

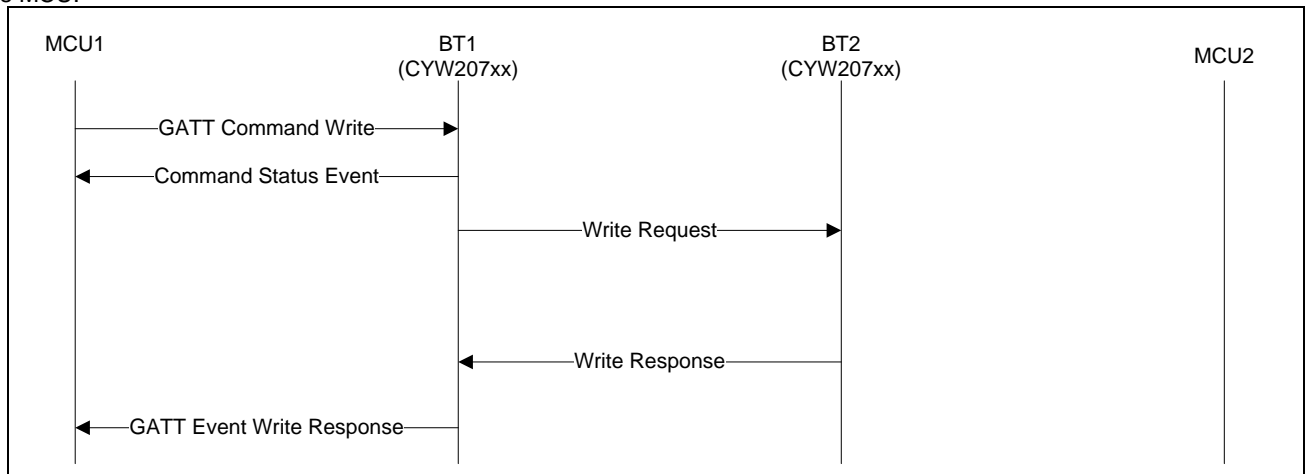

Figure 4-6. GATT Command Write Request – Peer MCU Not Involved in the Write

Figure 4-7 shows a GATT Command Write Request sequence where the peer device requires involvement from its MCU before executing the write.

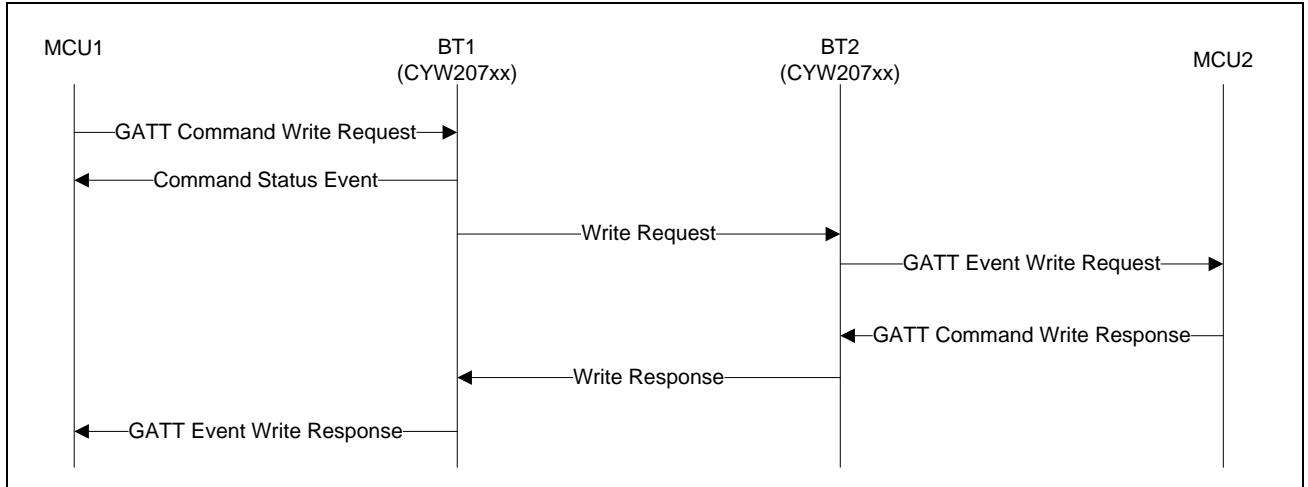

Figure 4-7. GATT Command Write Request – MCU Is Involved in a Write

### 4.3.8 GATT Command Write Response

The GATT Command Write Response command is used to confirm a received Write Request from a peer device. The connection handle and attribute handle should match the parameters received in GATT Event Write Request (see “GATT Event Write Request”). See Figure 4-7 for an example message sequence where this command is used.

When the command is received over the UART, the hci\_control application sends a GATT Event Write Response for the attribute handle received in the command.

Item	Description
Operating code	0x08
Parameters	Connection handle (2 bytes)
	Attribute handle (2 bytes)
	Status (1 byte) Note: Application status codes are typically 0x80 and higher.

Table 4-34. GATT Command Write Response



### 4.3.9 GATT Command Notify

The GATT Command Notify lets an MCU schedule the sending of a Notify packet over an established Bluetooth LE connection. The connection handle is a two-byte value reported in the LE Connected event (see “LE Connected”).

When the CYW207xx receives and processes this command, it takes one of the following actions:

- If the connection does not exist or the device is busy performing another action, such as discovery, reading, writing, etc., then it reports the relevant status in the Command Status event (see “Command Status”).
- If the connection exists and the device is not busy performing another action, then it reports Success in the Command Status event and starts the notification process.

The hci\_control application sends a notification with the attribute handle received in the command.

The CYW207xx has a fixed number of transmit buffers. If the hci\_control application allocates a buffer and schedules it for transmission, then the GATT Command Notify operation is considered complete and the hci\_control application sends the GATT Event Write Response (see “GATT Event Write Response”). If no transmit buffers are available, then the hci\_control application saves the notification data and delays sending the GATT Event Write Response until a transmit buffer becomes available and the data is scheduled for transmission. The MCU should not send new discovery, read, or write commands until after receiving the GATT Event Write Response.

Item	Description
Operating code	0x09
Parameters	Connection handle (2 bytes)
	Attribute handle (2 bytes)
	Data (variable bytes)

Table 4-35. GATT Command Notify

Figure 4-8 shows a GATT Command Notify message sequence where a peer server (BT1) is prompted by its MCU (MCU1) to send a characteristic value notification to the client (BT2).

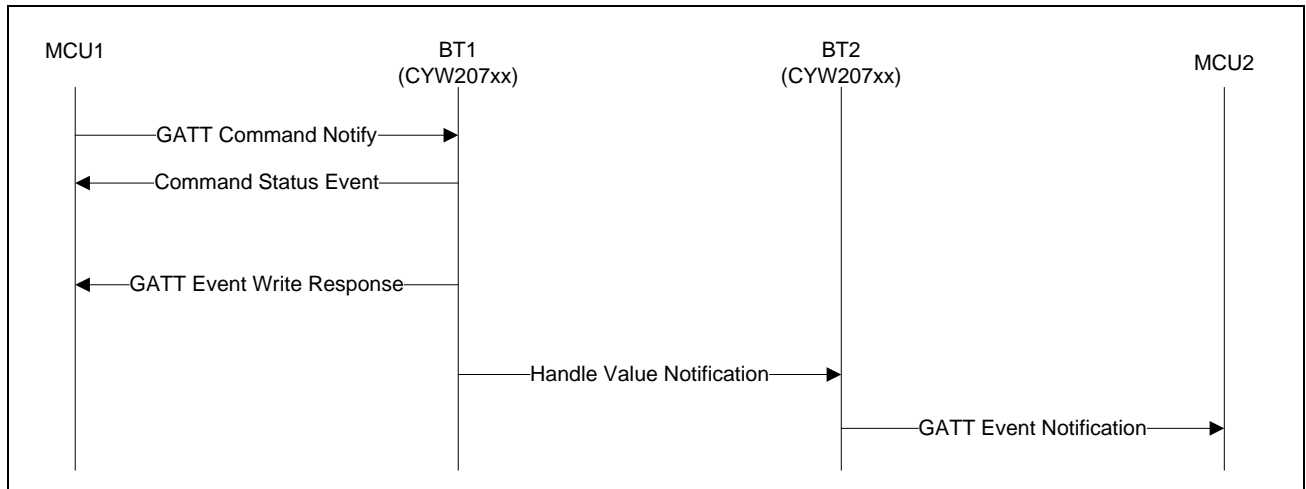

Figure 4-8. GATT Command Notify Message Sequence

### 4.3.10 GATT Command Indicate

The GATT Command Indicate lets an MCU perform a Value Indication procedure over an established Bluetooth LE connection. The connection handle is a two-byte value reported in the LE Connected event (see “LE Connected”).

When the CYW207xx receives and processes this command, it takes one of the following actions:

- If the connection does not exist or the device is busy performing another action, such as discovery, reading, writing, etc., then it reports the relevant status in the Command Status event (see “Command Status”).
- If the connection exists and the device is not busy performing another action, then it reports Success in the Command Status event and starts the indication process.

The hci\_control application sends a Handle Value Indication with the attribute handle received in the command. When a Handle Value Confirmation is received from the connected device, the hci\_control application sends the GATT Event Write Response (see “GATT Event Write Response”). The MCU should not send new discovery, read, or write commands until after receiving the GATT Event Write Response.

Item	Description
Operating code	0x0A
Parameters	Connection handle (2 bytes)
	Attribute handle (2 bytes)
	Data

Table 4-36. GATT Command Indicate

Figure 4-9 shows a GATT Command Indicate message sequence where a peer server (BT1) is prompted by its MCU (MCU1) to send a characteristic value indication to the client (BT2).

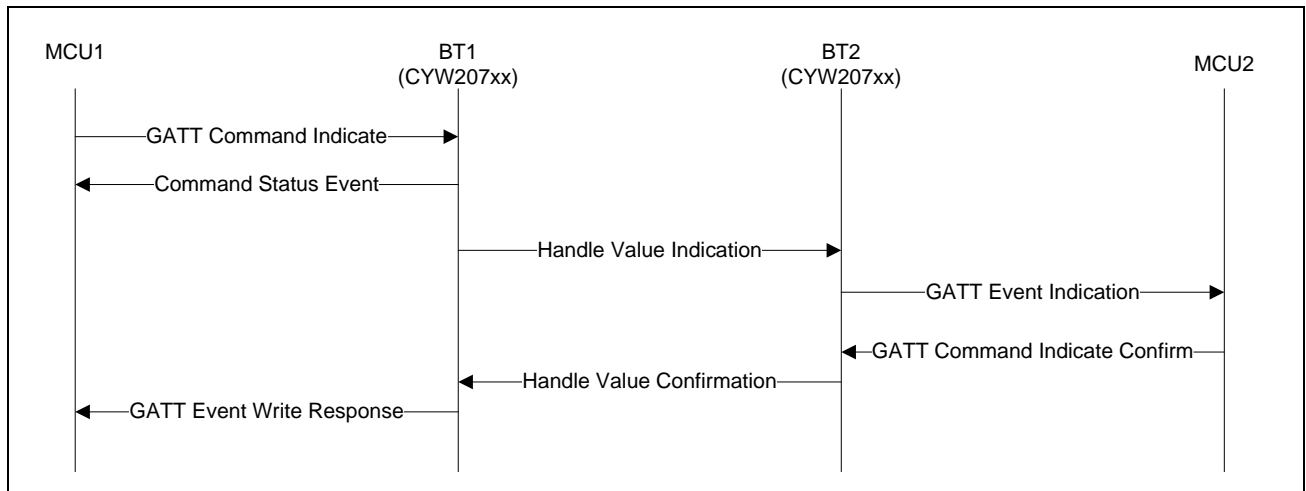

Figure 4-9. GATT Command Indicate Message Sequence

### 4.3.11 GATT Command Indicate Confirm

The GATT Command Indicate Confirm lets an MCU send a confirmation to an indication received from a peer device. The connection handle and attribute handle should match the parameters received in the GATT Event Indicate event (see “GATT Event Indication”).

When the command is received over the UART, the hci\_control application sends a Handle Value Confirmation (see [Figure 4-9](#)) for the attribute handle received in the command.

Item	Description
Operating code	0x0B
Parameters	Connection handle (2 bytes)
	Attribute handle (2 bytes)

Table 4-37. GATT Command Indicate Confirm

## 4.4 Hands-Free Commands— HCI\_CONTROL\_GROUP\_HF

The Hands-Free (HF) commands let an MCU perform various HF procedures using the CYW207xx.

### 4.4.1 HF Connect

The HF Connect command instructs the CYW207xx to try establishing a connection to a specified Audio Gateway (AG), which is typically a phone.

When a connection is established, the CYW207xx sends an HF Open event. The status field of that event tells whether the connection could be established or not.

Item	Description
Operating code	0x01
Parameters	AG Bluetooth device address (6 bytes)

Table 4-38. HF Connect Command

When the CYW207xx receives and processes this command, it:

- Allocates a handle for the connection.
- Starts paging the AG using the passed-in address.
- Establishes the Hands-free Profile-defined Service Level Connection (SLC) if the connection is created.
- Sends an HF Open event with the connection assigned handle and success/failure status.
- Sends an HF Connected event if the SLC gets established.

### 4.4.2 HF Disconnect

The HF Disconnect command instructs the CYW207xx to remove an existing connection to an AG.

Item	Description
Operating code	0x02
Parameters	Connection handle (2 bytes)

Table 4-39. HF Disconnect Command

When the CYW207xx receives and processes this command, it disconnects the connection identified by the passed handle. When the connection is disconnected, it sends an HF Closed event.

### 4.4.3 HF Open Audio

The HF Open Audio command instructs the CYW207xx to create an audio connection on the AG identified by the connection handle.

Item	Description
Operating code	0x03
Parameters	Connection handle (2 bytes)

*Table 4-40. HF Open Audio Command*

When the CYW207xx receives and processes this command, it attempts to open an audio connection on the AG identified by the passed connection handle. When an audio connection is established, it sends an HF Audio Open event.

### 4.4.4 HF Close Audio

The HF Close Audio command instructs the CYW207xx to close the audio connection on the AG identified by the connection handle.

Item	Description
Operating code	0x04
Parameters	Connection handle (2 bytes)

*Table 4-41. HF Close Audio Command*

When the CYW207xx receives and processes this command, it attempts to close an audio connection on the AG identified by the passed handle connection. When the audio connection is closed, it sends an HF Audio Close event.

### 4.4.5 HF Accept/Reject Audio Connection

The HF Accept/Reject Audio Connection command instructs the CYW207xx to accept/reject the SCO connection request on the AG identified by SCO index.

Item	Description	
Operating code	0x05	
Parameters	SCO index (2 bytes)	
	Flag (1 byte)	0: Reject Audio Connection Request 1: Accept Audio Connection Request

*Table 4-42. HF Accept/Reject Audio Connection Command*

When the CYW207xx receives and processes this command, it attempts to accept/reject the SCO connection on the AG identified by the passed handle connection.

#### 4.4.6 HF AT Commands

Each HF AT Command instructs the CYW207xx to send a specific AT command to an AG.

Item	Description
Operating code	See <a href="#">Table 4-44</a>
Parameters	Connection handle (2 bytes)
	Command code (1 byte)
	Numeric value (2 bytes)
	Optional supporting character string (variable bytes)

Table 4-43. HF AT Command

Table 4-44 shows various available settings for the command code, numeric value, and optional string parameters of the HF AT Command (see [Table 4-43](#)).

Command Code		Numeric Value	Optional String
Code	Description		
0x20	Speaker gain	0–15	–
0x21	Microphone gain	0–15	–
0x22	Answer incoming call	–	–
0x23	Get number from voice tag	1	–
0x24	Voice recognition	0: Disable 1: Enable	–
0x25	Last number redial	–	–
0x26	Call hold	0: Release all held calls 1: Release all active calls 2: Swap active and held calls 3: Hold active call	–
0x27	Hang up	–	–
0x28	Read indicator status	–	–
0x29	Retrieve subscriber number	–	–
0x2A	Dial	–	–
0x2B	Noise/Echo control	0: Disable 1: Enable	–
0x2C	Transmit DTMF tone	–	–
0x2D	Response and hold	0: Hold incoming call 1: Accept held incoming call 2: Reject held incoming call	–
0x2E	Get operator information	–	–
0x2F	Extended result codes	1: Enable	–
0x30	Get current call list	–	–
0x31	Indicator control	–	–
0x32	Send HF indicator	–	–
0x33	Send proprietary AT command	–	–

Table 4-44. HF AT Command Parameters

When the CYW207xx receives and processes this command, it attempts to send the corresponding AT command to the AG identified by the connection handle. When a response is received from the AG, it is sent back via an HF Response event (see “HF Response”). Another command should not be sent until after the response event is received.

## 4.5 Serial Port Profile Commands—HCI\_CONTROL\_GROUP\_SPP

The Serial Port Profile (SPP) commands let an MCU establish an SPP connection to a peer and send data.

### 4.5.1 SPP Connect

The MCU can send an SPP Connect command to the CYW207xx to establish an SPP connection to a specified device. Upon receiving the command, the CYW207xx establishes an ACL data connection, performs a Service Discovery Protocol (SDP) search for the RFCOMM service, and establishes an RFCOMM connection to that service.

If the operation is successful, the CYW207xx will send the SPP Connected event back to the MCU. If the operation fails, the SPP Connection Failed or SPP Service Not Found event is sent.

Item	Description
Operating code	0x01
Parameters	Bluetooth device address of the peer device (6 bytes)

Table 4-45. SPP Connect Command

### 4.5.2 SPP Disconnect

The MCU can send an SPP Disconnect command to disconnect a previously established SPP connection.

Item	Description	
Operating code	0x02	
Parameters	Connection handle (2 bytes)	The connection handle as reported in the SPP Connected event.

Table 4-46. SPP Disconnect Command

### 4.5.3 SPP Data

The MCU issues the SPP Data command to send data over an established SPP connection.

Upon receiving an SPP Data command, the CYW207xx attempts to allocate a buffer and queue a data packet for transmission. After the packet is enqueued, the CYW207xx sends the TX Completed event. If the queue is full because data is received over the UART faster than it can be delivered to the peer, then the TX Completed event is delayed until the operation can be completed.

Item	Description	
Operating code	0x03	
Parameters	Connection handle (2 bytes)	The connection handle as reported in the SPP Connected event.
	Data (variable bytes)	-

Table 4-47. SPP Data Command

## 4.6 Audio Commands— HCI\_CONTROL\_GROUP\_AUDIO

The audio commands let an MCU establish an AV source connection to a peer device over the AVDT protocol and then send data.

### 4.6.1 Audio Connect

The MCU can send an Audio Connect command to the CYW207xx to establish an AV Source connection to a specified device. Upon receiving the command, the CYW207xx establishes an ACL data connection, performs Service Discovery Protocol (SDP) searches for the A2DP service, and establishes an AVDTP signaling connection and the data channel.

If the operation succeeds, the CYW207xx will send the Audio Connected event back to the MCU. If the operation fails, the Audio Connection Failed, or Audio Service Not Found event is sent.

Item	Description	
Operating code	0x01	
Parameters	Address (6 bytes)	Bluetooth device address of the peer device.
	Audio route (1 byte)	0: I <sup>2</sup> S
		1: UART
		2: Sine (sends a sine wave)

Table 4-48. Audio Connect Command

### 4.6.2 Audio Disconnect

The MCU can send an Audio Disconnect command to disconnect a previously established AV source connection.

Item	Description	
Operating code	0x02	
Parameters	Connection handle (2 bytes)	The connection handle as reported in the Audio Connected event.

Table 4-49. Audio Disconnect Command

### 4.6.3 Audio Start

The MCU can send an Audio Start command to the CYW207xx to start streaming audio from the MCU to the remote device. Upon receiving the command, if the CYW207xx determines that it's appropriate and necessary, it reconfigures the channel for a new sampling frequency and/or channel mode. If successful, it begins requesting raw audio data from the MCU.

The MCU can send an Audio Start command only after an audio connection to the peer device has been established; that is, after an Audio Connected event has been received (see [“Audio Connected”](#)).

If the MCU was previously streaming data and it issued the Audio Stop command (see [“Audio Stop”](#)), it should not send another Audio Start command until after it receives the Audio Stopped event (see [“Audio Stopped”](#)).

Sending the Audio Start command configures the CYW207xx for specific stream settings, including sample frequency and channel mode. Configured parameters will persist across stream suspend and resume.

If the peer device disconnects and then reconnects (see [“Audio Connected”](#) and [“Audio Disconnected”](#)), the CYW207xx will not start streaming until the MCU resends the Audio Start command.

If the operation is successful, then the CYW207xx will send the Audio Started event (see [“Audio Started”](#)) back to the MCU. If the operation fails, then the Audio Stopped event (see [“Audio Stopped”](#)) will be sent.

Item	Description	
Operating code	0x03	
Parameters	Connection handle (2 bytes)	The connection handle as reported in the Audio Connected event.
	Sampling frequency (1 byte)	0: 16 kHz
		1: 32 kHz
		2: 44.1 kHz
Channel mode (1 byte)	3: 48 kHz.	
	0: Mono	
	1: Stereo	

Table 4-50. Audio Start Command

#### 4.6.4 Audio Stop

The MCU can send an Audio Stop command to the CYW207xx to stop streaming audio from the MCU, through the platform, to the remote device. Upon receiving the command, the CYW207xx stops requesting audio data buffers from the MCU. When the CYW207xx finishes sending queued data, it will send the Audio Stopped event (see “[Audio Stopped](#)”) to the MCU and, upon timeout (if not restarted), it will place the AVDTP connection in a suspended state.

Item	Description	
Operating code	0x04	
Parameters	Connection handle (2 bytes)	The connection handle as reported in the Audio Connected event.

Table 4-51. Audio Stop Command

After sending an Audio Stop command, an MCU should not send an Audio Start command until after it receives an Audio Stop event.

#### 4.6.5 Audio Data

The MCU can send an Audio Data command in response to an Audio Data Request event (see “[Audio Data Request](#)”). The Audio Data Request indicates the bytes per packet and number of packets that the MCU needs to send.

The Audio Data command from the MCU carries high-priority, real-time data. The type of raw PCM data (stereo/mono, sampling frequency) is set by the MCU in the Audio Start Command (see “[Audio Start](#)”).

Item	Description	
Operating code	0x06	
Parameters	PCM data packet length (2 bytes)	-
	PCM data (variable bytes)	Each 16-bit audio sample is 2 bytes.

Table 4-52. Audio Data Command



## 4.7 HID Device Commands: HCI\_CONTROL\_GROUP\_HIDD

The HID Device (HIDD) commands let an MCU perform various HIDD-related procedures using the CYW207xx.

### 4.7.1 HID Accept Pairing

The HID Accept Pairing command instructs the CYW207xx to enter or exit a discoverable and connectable mode. When the CYW207xx is in a discoverable and connectable mode, peer devices can find the device and establish a bonding relationship with it.

Item	Description
Operating code	0x01
Parameters	Enable (1 byte)

Table 4-53. HID Accept Pairing Command

When a peer device establishes a connection, the HID Opened event (see “[HID Opened](#)”) will be sent to the MCU. At that time, the MCU can start sending HID reports.

### 4.7.2 HID Send Report

When a connection is established, the MCU can send a HID report over the HID interrupt or control channel. The report should be a fully formatted packet, including the Report ID and the data.

Item	Description	
Operating code	0x02	
Parameters	Report channel (1 byte)	0: Control 1: Interrupt
	Report type (1 byte)	0: Other 1: Input 2: Output 3: Feature
	Report data (variable bytes)	

Table 4-54. HID Send Report Command

If the CYW207xx is not connected to a paired host when it receives a HID Send Report command, it will try to establish a HID connection. When this happens, the report will be lost.

### 4.7.3 HID Push Pairing Host Info

If the CYW207xx is not connected to external serial flash, then the MCU is responsible for storing the paired host information. At start-up, the MCU should download the paired host information that it previously received in an NVRAM Data event (see “[NVRAM Data](#)”).

Item	Description	
Operating code	0x03	
Parameters	Data (variable bytes)	Data received in the NVRAM Data event.

Table 4-55. HID Push Pairing Host Info Command

#### 4.7.4 HID Connect

The HID Connect command instructs the CYW207xx to try establishing a connection to a previously paired HID host. Prior to issuing this command, information about the host, including the Bluetooth device address and link key, should be downloaded to the CYW207xx using the HID Push Pairing Host Info command.

When a connection is established, the CYW207xx sends a HID Opened event (see “HID Opened”).

Item	Description	
Operating code	0x04	
Parameters	Address (6 bytes)	Bluetooth device address of the HID host to which a connection is made.

Table 4-56. HID Connect Command

### 4.8 AV Remote Control Target Commands: HCI\_CONTROL\_GROUP\_AVRC\_TARGET

#### 4.8.1 AVRC Target Connect

**Note:** This command should only be used in the case of PTS testing. Target side connections are made in conjunction with the Audio Source connections.

The MCU can send this to the CYW207xx to establish an AV remote control target connection to a specified device. Upon receiving this command, the CYW207xx establishes an ACL data connection if one does not exist yet, performs the Service Discovery Protocol (SDP), searches for the AVRC service, and establishes an AVCTP channel.

If the operation succeeds, the CYW207xx sends the AVRC Connected event (see “AVRC Controller Connected”) back to the MCU. If the operation fails, the CYW207xx sends the AVRC Disconnected event (see “AVRC Controller Disconnected”).

Item	Description	
Operating code	0x01	
Parameters	bd_addr (6 bytes)	Bluetooth address of the peer device.

Table 4-57. AVRC Target Connect Command

#### 4.8.2 AVRC Target Disconnect

**Note:** This command should only be used in the case of PTS testing. Target side connections are made in conjunction with the Audio Source connections.

The MCU can send this command to disconnect a previously established AV remote control connection.

Item	Description	
Operating code	0x02	
Parameters	-	

Table 4-58. AVRC Target Disconnect Command

### 4.8.3 AVRC Target Track Information

The MCU can send this command to the CYW207xx to inform it of updates to the track information for the currently playing track. The MCU shall send information about all changed attributes in a single command. The command can include all attributes or it can be limited to one or several attributes. For example one could send Title and Track Number if only those attributes have changed. If an attribute is not available for the new track, the MCU should include the attribute with length of zero.

Item	Description	
Operating code	0x05	
Parameters	Attribute Id of the first attribute (1 byte)	1: Title 2: Artist 3: Album 4: Track number 5: Number of tracks 6: Genre 7: Playing time
	Attribute Length of the first attribute (1 byte)	Attribute string length
	Attribute Value of the first attribute (n bytes as defined above)	Attribute value expressed as a character string.
	Attribute Id of the second attribute (1 byte)	(see list above)
	Attribute Length of the second attribute (1 byte)	Attribute string length
	Attribute Value of the second attribute (n bytes as defined above)	Attribute value expressed as a character string.
	... (up to 7 entries)	...

Table 4-59. AVRC Target Track Information Command

### 4.8.4 AVRC Target Player Status

The MCU can send this command to the CYW207xx with the player play state and track position information. It is mandatory for the MCU to send this status update for every change in the playback status of the local player. If last reported status is *playing*, the CYW207xx will assume that the track position on the player is continuously updating 1000 ms every second. The MCU must send the Track Position only if changes are not due to the standard playback. For example, the command needs to be sent regularly if the player is performing fast forward or rewind operations, or if the position jumps due to the local update on the player.

Item	Description	
Operating code	0x06	
Parameters	Play State	0x00: STOPPED 0x01: PLAYING 0x02: PAUSED 0x03: FWD_SEEK 0x04: REV_SEEK
	Track Length (4 bytes)	Length of the current track in milliseconds
	Track Position (4 bytes)	Position in the current track in ms within Track Length defined above.

Table 4-60. AVRC Target Player Status Command

#### 4.8.5 AVRC Target Repeat Mode Changed

The MCU can send this command to the CYW207xx to inform the CYW207xx of a change in the mode of the local player repeat setting.

Item	Description	
Operating code	0x07	
Parameters	Repeat Mode	0x01: Off 0x02: Single Track Repeat 0x03: All Track Repeat 0x04: Group Repeat

Table 4-61. AVRC Target Repeat Mode Changed Command

#### 4.8.6 AVRC Target Shuffle Mode Changed

The MCU can send this command to the CYW207xx to inform the CYW207xx of a change in the mode of the local player shuffle setting.

Item	Description	
Operating code	0x08	
Parameters	Shuffle Mode	0x01: Off 0x02: All Track Scan 0x04: Group Scan

Table 4-62. AVRC Target Shuffle Mode Changed Command

#### 4.8.7 AVRC Target Equalizer Status Changed

The MCU can send this command to the CYW207xx to inform the CYW207xx of a toggle in the On/Off status of the local player equalizer.

Item	Description	
Operating code	0x09	
Parameters	Equalizer Status	0x01: Off 0x02: On

Table 4-63. AVRC Target Equalizer Status Changed Command

#### 4.8.8 AVRC Target Scan Mode Changed

The MCU can send this command to the CYW207xx to reflect the change of the status of the local player scan control setting.

Item	Description	
Operating code	0x0A	
Parameters	Scan Mode	0x01: Off 0x02: All Track Scan 0x04: Group Scan

Table 4-64. AVRC Target Scan Mode Changed Command

## 4.9 AV Remote Control Controller Commands: HCI\_CONTROL\_GROUP\_AVRC\_CONTROLLER

The AV Remote Control controller group of the commands are used by the MCU when implementing a remote control application. For example the MCU can send play, pause and other commands to the remote connected Bluetooth player.

### 4.9.1 AVRC Controller Connect

The MCU can send this to the CYW207xx to establish an AV remote control connection to a specified device. Upon receiving this command, the CYW207xx establishes an ACL data connection if one does not exist yet, performs the Service Discovery Protocol (SDP), searches for the AVRC service, and establishes an AVCTP channel.

If the operation succeeds, the CYW207xx sends the AVRC Connected event back to the MCU. If the operation fails, the CYW207xx sends the AVRC Disconnected event.

**Note:** This command should only be used in the case of a standalone AVRC Controller application. If remote controller functionality is combined with the speaker, the AVRC command will be established automatically when audio connection is established.

Item	Description	
Operating code	0x01	
Parameters	bd_addr (6 bytes)	Bluetooth address of the peer device

Table 4-65. AVRC Controller Connect Command

### 4.9.2 AVRC Controller Disconnect

The MCU can send this command to disconnect a previously established AV remote control connection.

Item	Description	
Operating code	0x02	
Parameters	bd_addr (6 bytes)	Bluetooth address of the peer device

Table 4-66. AVRC Controller Disconnect Command

### 4.9.3 AVRC Controller Play

The MCU sends this command to start playing audio on the connected Bluetooth media player.

Item	Description	
Operating code	0x03	
Parameters	Connection handle (2 bytes)	The connection handle as reported in the AVRC Connected event (see <a href="#">“AVRC Controller Connected”</a> ).

Table 4-67. AVRC Controller Play Command

#### 4.9.4 AVRC Controller Stop

The MCU sends this command to stop playing audio on the connected Bluetooth media player.

Item	Description	
Operating code	0x04	
Parameters	Connection handle (2 bytes)	The connection handle as reported in the AVRC Connected event (see "AVRC Controller Connected").

Table 4-68. AVRC Controller Stop Command

#### 4.9.5 AVRC Controller Pause

The MCU sends this command to pause playing audio on the connected Bluetooth media player.

Item	Description	
Operating code	0x05	
Parameters	Connection handle (2 bytes)	The connection handle as reported in the AVRC Connected event (see "AVRC Controller Connected").

Table 4-69. AVRC Controller Pause Command

#### 4.9.6 AVRC Controller Begin Fast Forward

The MCU sends this command to begin fast forward operation on the connected Bluetooth media player. Unlike most of the other AVRC commands, this command initiates the mode where the player plays audio at high speed. Use the AVRC End Fast Forward command to terminate this mode.

Item	Description	
Operating code	0x06	
Parameters	Connection handle (2 bytes)	The connection handle as reported in the AVRC Connected event (see "AVRC Controller Connected").

Table 4-70. AVRC Controller Begin Fast Forward Command

#### 4.9.7 AVRC Controller End Fast Forward

The MCU sends this command to terminate fast forward operation on the connected Bluetooth media player.

Item	Description	
Operating code	0x07	
Parameters	Connection handle (2 bytes)	The connection handle as reported in the AVRC Connected event (see "AVRC Controller Connected").

Table 4-71. AVRC Controller End Fast Forward Command

#### 4.9.8 AVRC Controller Begin Rewind

The MCU sends this command to begin rewind operation on the connected Bluetooth media player. Unlike most of the other AVRC commands, this command initiates the mode where the player plays audio in reverse at high speed. Use the AVRC End Rewind command to terminate this mode.

Item	Description	
Operating code	0x08	
Parameters	Connection handle (2 bytes)	The connection handle as reported in the AVRC Connected event (see <a href="#">"AVRC Controller Connected"</a> ).

Table 4-72. AVRC Controller Begin Rewind Command

#### 4.9.9 AVRC Controller End Rewind

The MCU sends this command to terminate rewind operation on the connected Bluetooth media player.

Item	Description	
Operating code	0x09	
Parameters	Connection handle (2 bytes)	The connection handle as reported in the AVRC Connected event (see <a href="#">"AVRC Controller Connected"</a> ).

Table 4-73. AVRC Controller End Rewind Command

#### 4.9.10 AVRC Controller Next Track

The MCU sends this command to instruct the player to move to the next track on the connected Bluetooth media player.

Item	Description	
Operating code	0x0A	
Parameters	Connection handle (2 bytes)	The connection handle as reported in the AVRC Connected event (see <a href="#">"AVRC Controller Connected"</a> ).

Table 4-74. AVRC Controller Next Track Command

#### 4.9.11 AVRC Controller Previous Track

The MCU sends this command to instruct the player to move to the previous track on the connected Bluetooth media player.

Item	Description	
Operating code	0x0B	
Parameters	Connection handle (2 bytes)	The connection handle as reported in the AVRC Connected event (see <a href="#">"AVRC Controller Connected"</a> ).

Table 4-75. AVRC Controller Previous Track Command

#### 4.9.12 AVRC Controller Volume Up

The MCU can send this command to the CYW207xx to request a volume increase on a connected AV player.

Item	Description	
Operating code	0x0C	
Parameters	Connection handle (2 bytes)	The connection handle as reported in the AVRC Connected event (see <a href="#">"AVRC Controller Connected"</a> ).

Table 4-76. AVRC Controller Volume Up Command

#### 4.9.13 AVRC Controller Volume Down

The MCU can send this command to the CYW207xx to request a volume decrease on a connected AV player.

Item	Description	
Operating code	0x0D	
Parameters	Connection handle (2 bytes)	The connection handle as reported in the AVRC Connected event (see <a href="#">"AVRC Controller Connected"</a> ).

Table 4-77. AVRC Controller Volume Down Command

#### 4.9.14 AVRC Controller Get Track Information

This is an optional command that an MCU can send to a CYW207xx in order to retrieve the current track information from the target player. The CYW207xx sends a request for the current track attributes to the peer. When the player responds the CYW207xx will send an event to the MCU for each of the track elements that it has retrieved. This can be invoked at any time or the MCU can choose to do so when informed by the CYW207xx of a track change (see ["AVRC Controller Track Change"](#)).

Item	Description	
Operating code	0x0E	
Parameters	Connection handle (2 bytes)	The connection handle as reported in the Audio Connected event.
	Number of attributes (1 byte)	Number of attributes to return. 0 to return all attributes.
	Attributes (1 to 8 bytes)	Each byte represents an attribute to retrieve. Attribute values indicate the following options: 1: Title 2: Artist 3: Album 4: Track number 5: Number of tracks 6: Genre 7: Playing time

Table 4-78. AVRC Controller Get Track Information Command



#### 4.9.15 AVRC Controller Set Equalizer Status

The MCU can send this command to the CYW207xx to toggle the on/off state of the target player equalizer. The CYW207xx reports the initial state of the equalizer and subsequent state changes using the AVRC Setting Change event (see “[AVRC Controller Setting Change](#)”).

Item	Description	
Operating code	0x0F	
Parameters	Connection handle (2 bytes)	The connection handle as reported in the Audio Connected event (see “ <a href="#">Audio Connected</a> ”).

Table 4-79. AVRC Controller Set Equalizer Status Command

#### 4.9.16 AVRC Controller Set Repeat Mode

The MCU can send this command to the CYW207xx to change the repeat mode of the target player. Each command submitted by the MCU will change the setting to the next available on the remote, cycling through all possible settings one at a time. The CYW207xx reports the initial repeat-mode state and subsequent state changes using the AVRC Setting Change event (see “[AVRC Controller Setting Change](#)”).

Item	Description	
Operating code	0x10	
Parameters	Connection handle (2 bytes)	The connection handle as reported in the Audio Connected event (see “ <a href="#">Audio Connected</a> ”).

Table 4-80. AVRC Controller Set Repeat Mode Command

#### 4.9.17 AVRC Controller Set Shuffle Mode

The MCU can send this command to the CYW207xx to change the shuffle mode of the target player. Each command submitted by the MCU will change the setting on the remote to the next available setting, cycling through all possible settings one at a time. The CYW207xx reports the initial shuffle-mode state and subsequent state changes using the AVRC Setting Change event (see “[AVRC Controller Setting Change](#)”).

Item	Description	
Operating code	0x11	
Parameters	Connection handle (2 bytes)	The connection handle as reported in the Audio Connected event (see “ <a href="#">Audio Connected</a> ”).

Table 4-81. AVRC Controller Set Shuffle Mode Command

#### 4.9.18 AVRC Controller Set Scan Status

The MCU can send this command to the CYW207xx to change the scan status of the target player. Each command submitted by the MCU will change the setting on the remote to the next available setting, cycling through all possible settings one at a time. The CYW207xx reports the initial scan status and subsequent status changes in the AVRC Setting Change event (see [“AVRC Controller Setting Change”](#)).

Item	Description	
Operating code	0x12	
Parameters	Connection handle (2 bytes)	The connection handle as reported in the Audio Connected event (see <a href="#">“Audio Connected”</a> ).

Table 4-82. AVRC Controller Set Scan Status Command

#### 4.9.19 AVRC Controller Set Volume

The MCU can send this command to the CYW207xx to pass a new volume setting to the connected AV sink device. An MCU should use this command only if the *Absolute Volume Capable* flag is true as indicated in the Audio Connected event (see [Audio Connected](#)).

Item	Description	
Operating code	0x13	
Parameters	Connection handle (2 bytes)	The connection handle as reported in the Audio Connected event (see <a href="#">“Audio Connected”</a> ).
	Volume level (1 byte)	The percentage (0 to 100) of the maximum volume level to be used by a connected peer device.

Table 4-83. AVRC Controller Set Volume Command

### 4.10 Test Commands— HCI\_CONTROL\_GROUP\_TEST

The Test commands allow the host to execute various tests on the CYW207xx.

#### 4.10.1 Encapsulated HCI Command

Primarily for manufacturing test purposes, this test command allows the host to send encapsulated HCI commands to the CYW207xx to control the BT controller for RF test purposes. For example, Bluetooth LE RF testing usually requires the support of the LE Transmitter Test, LE Receiver Test, and LE Test End HCI commands (see [BLUETOOTH SPECIFICATION Version 4.2 \[Vol 2, Part E\]](#), Section 7.8.28, 7.8.29, and 7.8.30 [2] for details). All of which can be formatted into this Encapsulated HCI Command.

The CYW207xx also provides support for Vendor Specific commands (*Radio\_Tx\_Test* and *Radio\_Rx\_Test*) which enable a connectionless transmit and receive mode to send and receive respectively Bluetooth packets at a specified frequency. Please refer to the WMBT tool included in WICED Studio under Tools\wmbt.

When the CYW207xx receives a test command, it is put into a Test Mode. While in the Test Mode all the events received from the controller are passed to the MCU as Encapsulated HCI Events (see [Encapsulated HCI Event](#)) and not processed by the stack. Because of that the CYW207xx must be reset and reinitialized to continue normal application operation.

Item	Description	
Operating code	0x10	
Parameters	HCI Command (variable bytes)	Fully formatted HCI Command.

Table 4-84. Encapsulated HCI Command

## 4.11 ANCS Commands: HCI\_CONTROL\_GROUP\_ANCS

The Apple Notification Control Service (ANCS) commands let an MCU perform various ANCS-related procedures using the CYW207xx. Refer to the Apple ANCS Specification [3] for more information.

### 4.11.1 ANCS Action

This command instructs the CYW207xx to pass a positive or negative action with respect to a specific notification sent by the iOS device. The command is sent after the CYW207xx reports the notification in the ANCS Notification event (see “ANCS Notification”).

Item	Description	
Operating code	0x01	
Parameters	Notification ID (4 bytes)	The Notification ID as reported in the ANCS Notification Event.
	Action (1 byte)	0: Positive action. 1: Negative action.

Table 4-85. ANCS Action Command

### 4.11.2 ANCS Connect

This command instructs the CYW207xx to activate the ANCS service on the iOS device connected to the given LE Connection Handle. The MCU should not send this command until after it has received the ANCS Service Found event and has verified that the LE connection is Encrypted since the ANCS service requires Authentication.

Item	Description	
Operating code	0x02	
Parameters	Connection Handle (2 bytes)	The connection handle reported in the LE Connected event.

Table 4-86. ANCS Connect Command

### 4.11.3 ANCS Disconnect

This command instructs the CYW207xx to deactivate the ANCS service on the iOS device connected to the given LE Connection Handle by unsubscribing to notifications for the service.

Item	Description	
Operating code	0x03	
Parameters	Connection Handle (2 bytes)	The connection handle reported in the LE Connected event.

Table 4-87. ANCS Disconnect Command

## 4.12 AMS Commands: HCI\_CONTROL\_GROUP\_AMS

The Apple Media Service (AMS) commands let an MCU perform various AMS-related procedures using the CYW207xx. Refer to the Apple developer AMS Specification [4] for more information:

### 4.12.1 AMS Connect

This command instructs the CYW207xx to activate the AMS service on the iOS device connected to the given LE Connection Handle. The MCU should not send this command until after it has received the AMS Service Found event and has verified that the LE connection is Encrypted since the AMS service requires Authentication.

Item	Description	
Operating code	0x01	
Parameters	Connection Handle (2 bytes)	The connection handle reported in the LE Connected event.

Table 4-88. AMS Connect Command

### 4.12.2 AMS Disconnect

This command instructs the CYW207xx to deactivate the AMS service on the iOS device connected to the given LE Connection Handle by unsubscribing to notifications for the service.

Item	Description	
Operating code	0x02	
Parameters	Connection Handle (2 bytes)	The connection handle reported in the LE Connected event.

Table 4-89. AMS Disconnect Command

## 4.13 iAP2 Commands: HCI\_CONTROL\_GROUP\_IAP2

The Apple iPod Accessory Protocol (iAP2) commands allows an MCU to establish and send data over an iAP2 External Accessory (EA) session implemented on a CYW207xx.

### 4.13.1 IAP2 Connect

The MCU can send this command to the CYW207xx to establish an EA session with a specified device. Upon receiving the command, the CYW207xx establishes an ACL data connection, performs an SDP search for the iAP2 service, and establishes an EA session to the iAP2 service.

After the EA session is successfully established, the CYW207xx will send an IAP2 Connected event (see "IAP2 Connected") back to the MCU. If the operation fails, then either the IAP2 Connection Failed event (see "IAP2 Connection Failed") or IAP2 Service Not Found event (see "IAP2 Service Not Found") is sent.

Item	Description	
Operating code	0x01	
Parameters	bd_addr (6 bytes)	Bluetooth address of the peer device.

Table 4-90. IAP2 Connect Command

### 4.13.2 IAP2 Disconnect

The MCU can send this command to disconnect a previously established EA session.

Item	Description	
Operating code	0x02	
Parameters	Session handle (2 bytes)	The session handle as reported in the IAP2 Connected event (see <a href="#">"IAP2 Connected"</a> ).

Table 4-91. IAP2 Disconnect Command

### 4.13.3 IAP2 Data

An MCU issues this command to send data over an established EA session.

Upon receiving this command, the CYW207xx attempts to allocate a buffer and queue a data packet for transmission. After successfully enqueueing a packet, the CYW207xx sends the IAP2 TX Complete event (see ["IAP2 TX Complete"](#)). If the queue is full because data is received over the UART faster than it can be delivered to the peer, then the sending of the TX Completed event is delayed until after the packet is successfully enqueue.

Item	Description	
Operating code	0x03	
Parameters	Session handle (2 bytes)	The session handle as reported in the IAP2 Connected event (see <a href="#">"IAP2 Connected"</a> ).
	Data (variable bytes)	Data to be transmitted to the iOS device.

Table 4-92. IAP2 Data Command

### 4.13.4 IAP2 Get Auth Chip Info

The MCU can send this command to read the chip information from the authentication coprocessor connected to the CYW207xx.

Item	Description
Operating code	0x04
Parameters	-

Table 4-93. IAP2 Get Auth Chip Info Command

## 4.14 Hands-free AG Commands: HCI\_CONTROL\_GROUP\_AG

The Hands-free AG commands let an MCU establish signaling and audio connections to a peer hands-free device. The current version of the protocol defined in this document supports a simple implementation that can be used only for voice control and not for actual calls, conferences, and more.

### 4.14.1 AG Connect

An MCU can send this command to the CYW207xx to establish an hands-free audio gateway connection to a specified device. Upon receiving the command, the CYW207xx establishes an ACL data connection, performs an SDP search for the RFCOMM service, establishes a connection with the RFCOMM service, and establishes a signaling connection with the specified hands-free device.

After an AG connection is successfully established, the CYW207xx will send the AG Connected event (see "[AG Connected](#)") back to the MCU.

Item	Description	
Operating code	0x01	
Parameters	bd_addr (6 bytes)	Bluetooth address of the peer device.

Table 4-94. AG Connect Command

### 4.14.2 AG Disconnect

An MCU can send this command to disconnect a previously established AG signaling connection.

Item	Description	
Operating code	0x02	
Parameters	Session handle (2 bytes)	The session handle as reported in the AG Connected event (see " <a href="#">AG Connected</a> ").

Table 4-95. AG Disconnect Command

### 4.14.3 AG Audio Connect

An MCU can send this command to establish an audio channel over a previously established AG signaling connection.

Item	Description	
Operating code	0x03	
Parameters	Session handle (2 bytes)	The session handle as reported in the AG Connected event (see " <a href="#">AG Connected</a> ").

Table 4-96. AG Audio Connect Command

#### 4.14.4 AG Audio Disconnect

An MCU can send this command to disconnect the audio channel previously established over the AG signaling connection.

Item	Description	
Operating code	0x04	
Parameters	Session handle (2 bytes)	The session handle as reported in the AG Connected event (see "AG Connected").

Table 4-97. AG Audio Disconnect Command

### 4.15 AIO Server Commands: HCI\_CONTROL\_GROUP\_AIO\_SERVER

The Automation IO (AIO) server commands let an MCU perform various AIO server procedures using the CYW207xx.

#### 4.15.1 AIO Digital Input

This command allows an MCU to simulate a change in an AIO server digital input.

Item	Description	
Operating code	0x01	
Parameters	Index (1 byte)	Index of digital IO, starting with 0.
	Data (variable bytes)	An array of 2-bit values in a bit field in little endian order, which identifies the state of the digital input. 00: Inactive state 01: Active state 10: Tristate 11: Unknown state

Table 4-98. AIO Digital Input Command

After a CYW207xx receives this command, it sets the new value in the database and, if a value/time trigger is set and the condition is met, sends a notification or indication with the new value to the AIO client.

#### 4.15.2 AIO Analog Input

This command allows an MCU to indicate a change in an AIO server analog input value.

Item	Description	
Operating code	0x02	
Parameters	Index (1 byte)	Index of digital IO, starting with 0.
	Data (2 bytes)	The value of the analog signal as an unsigned 16-bit integer.

Table 4-99. AIO Analog Input Command

After a CYW207xx receives this command, it sets the new value in the database and, if a value/time trigger is set and the condition is met, sends a notification or indication with the new value to the AIO client.

## 4.16 AIO Client Commands: HCI\_CONTROL\_GROUP\_AIO\_CLIENT

The Automation IO Client commands let an MCU perform various AIO client procedures using the CYW207xx.

### 4.16.1 AIO Connect

This command instructs the AIO client on a CYW207xx to connect to an AIO server.

Item	Description	
Operating code	0x01	
Parameters	bd_addr (6 bytes)	Bluetooth address of the AIO server to which a connection is made.

Table 4-100. AIO Connect Command

After the CYW207xx receives this command, it tries to establish a connection to the specified AIO server. If a Bluetooth device address is not specified or set to all zeros, it starts LE scanning and connects to the first AIO server it finds. After a connection is established, the CYW207xx performs characteristic and characteristic descriptor discoveries.

### 4.16.2 AIO Read

This command instructs the AIO client on a CYW207xx to read a value from the AIO server.

Item	Description	
Operating code	0x02	
Parameters	Type (1 byte)	1: Analog IO 2: Digital IO 3: Aggregate IO
	Index (1 byte)	Index of the analog, digital, or aggregate IO, starting with 0.

Table 4-101. AIO Read Command

After a CYW207xx receives this command, it sends a read request to the AIO server. After a read response comes back from the AIO server, the CYW207xx will send the value back to the MCU in an AIO Read Response event (see “[AIO Read Response](#)”).

### 4.16.3 AIO Write

This command instructs the AIO client on a CYW207xx to write a value to the AIO server.

Item	Description	
Operating code	0x03	
Parameters	Type (1 byte)	1: Analog IO 2: Digital IO
	Index (1 byte)	Index of the analog or digital IO, starting with 0.
	Data (variable bytes)	An unsigned 16-bit integer for analog IO, or an array of 2-bit values in a bit field for digital IO.

Table 4-102. AIO Write Command

After the CYW207xx receives this command, it sends a write request to the AIO server.



#### 4.16.4 AIO Register for Notification

This command instructs the AIO client on a CYW207xx to register for notification or indication on the AIO server.

Item	Description	
Operating code	0x04	
Parameters	Type (1 byte)	1: Analog IO 2: Digital IO 3: Aggregate IO
	Index (1 byte)	Index of the analog or digital IO, starting with 0.
	Value (1 byte)	0: Unregister notification/indication 1: Register for notification 2: Register for indication

Table 4-103. AIO Register for Notification Command

After a CYW207xx receives this command, it sends a write request to the AIO server to set a client characteristic configuration descriptor. The notification and/or indication configuration is set through a combination of the client characteristic configuration descriptor and the value and/or time trigger settings. See “AIO Set Value Trigger” and “AIO Set Time Trigger” for information regarding setting value and time triggers.

#### 4.16.5 AIO Set Value Trigger

This command instructs the AIO client on a CYW207xx to set a value trigger on the AIO server.

Item	Description	
Operating code	0x06	
Parameters	Type (1 byte)	1: Analog IO 2: Digital IO
	Index (1 byte)	Index of the analog or digital IO, starting with 0.
	Condition (1 byte)	0: Value changed 1: Crossed boundary 2: On the boundary 3: Value change exceeds a set value 4: Mask then compare 5: Crossed boundaries 6: On the boundaries 7: No value trigger
	Values (variable bytes)	These bytes are a function of the condition set. They represent one or more boundaries or a set value.

Table 4-104. AIO Set Value Trigger Command

After a CYW207xx receives this command, it sends a write request to an AIO server to set a value trigger descriptor.

#### 4.16.6 AIO Set Time Trigger

This command instructs the AIO client on a CYW207xx to set a time trigger on the AIO server.

Item	Description	
Operating code	0x07	
Parameters	Type (1 byte)	1: Analog IO 2: Digital IO
	Index (1 byte)	Index of the analog or digital IO, starting with 0.
	Condition (1 byte)	0: No time trigger 1: Periodic 2: Not more often than a set time 3: Value changed N times, where N is a count that can be set.
	Values (variable bytes)	These bytes are a function of the condition set.

Table 4-105. AIO Set Time Trigger Command

After a CYW207xx receives this command, it sends a write request to the AIO server to set a time trigger descriptor.

#### 4.16.7 AIO Set User Description

This command instructs the AIO client on a CYW207xx to set the user description on the AIO server.

Item	Description	
Operating code	0x08	
Parameters	Type (1 byte)	1: Analog IO 2: Digital IO
	Index (1 byte)	Index of the analog or digital IO, starting with 0.
	Description (variable bytes)	User description

Table 4-106. AIO Set User Description Command

#### 4.16.8 AIO Disconnect

This command instructs the AIO client on a CYW207xx to disconnect from the AIO server.

Item	Description
Operating code	0x09
Parameters	-

Table 4-107. AIO Disconnect Command

After a CYW207xx receives this command, it terminates its connection with the AIO server.

### 4.17 Audio Sink Commands: HCI\_CONTROL\_GROUP\_AUDIO\_SINK

The audio sink commands let an MCU establish an AV sink connection to a peer device over the AVDT protocol.

### 4.17.1 Audio Sink Connect

The Audio Sink Connect command instructs the CYW207xx to establish an AV Sink connection to a specified device. Upon receiving the command, the CYW207xx establishes an ACL data connection, performs Service Discovery Protocol (SDP) searches for the A2DP service, and establishes an AVDTP signaling connection. It is source responsibility to discover and configure streaming endpoint.

If the operation succeeds, the CYW207xx will send the Audio Sink Connected event back to the MCU. If the operation fails, the Audio Sink Connection Failed, or Audio Sink Service Not Found event is sent.

Item	Description	
Operating code	0x01	
Parameters	Address (6 bytes)	Bluetooth device address of the peer device.

Table 4-108 Audio Sink Connect Command

### 4.17.2 Audio Sink Disconnect

The Audio Sink Disconnect command instructs the CYW207xx to disconnect a previously established AV sink connection.

Item	Description	
Operating code	0x02	
Parameters	Connection handle (2 bytes)	The connection handle as reported in the Audio Sink Connected event.

Table 4-109 Audio Sink Disconnect Command

### 4.17.3 Audio Sink Start

The Audio Sink Start command instructs the CYW207xx to send start audio streaming request from the MCU to the remote device. Upon receiving the command, if the CYW207xx determines that it's appropriate and necessary, it configures the codec settings, audio route and sends AVDTP START request to peer device.

The MCU can send an Audio Sink Start command only after an audio sink connection to the peer device has been established; that is, after an Audio Sink Connected event has been received (see ["Audio Sink Connected"](#)).

If the MCU was previously streaming data and it issued the Audio Sink Stop command (see ["Audio Sink Stop"](#)), it should not send another Audio Sink Start command until after it receives the Audio Sink Stopped event (see ["Audio Sink Stopped"](#)).

If the operation is successful, then the CYW207xx will send the Audio Sink Started event (see ["Audio Sink Started"](#)) back to the MCU. If the operation fails, then the Audio Stopped event (see ["Audio Sink Stopped"](#)) will be sent.

Item	Description	
Operating code	0x03	
Parameters	Connection handle (2 bytes)	The connection handle as reported in the Audio Connected event.

Table 4-110 Audio Sink Start Command

### 4.17.4 Audio Sink Stop

The Audio Sink Stop command instructs the CYW207xx to send stop streaming the audio to the remote device. Upon receiving the command, the CYW207xx resets codec and sends AVDTP SUSPEND request to the peer. When the CYW207xx receives AVDTP SUSPEND CONFIRM event from peer, it sends Audio Sink Stopped event (see ["Audio Sink Stopped"](#)) to the MCU.

Item	Description	
Operating code	0x04	

Parameters	Connection handle (2 bytes)	The connection handle as reported in the Audio Sink Connected event.
------------	-----------------------------	--

Table 4-111 Audio Sink Stop Command

### 4.17.5 Audio Sink Start Response

The Audio Sink Start Response command instructs the CYW207xx to accept/reject the Audio Stream Start request identified by connection handle.

Item	Description	
Operating code	0x05	
Parameters	Connection handle (2 bytes)	The connection handle as reported in the Audio Sink Connected event.
	Label (1 byte)	Transaction Label received in Audio Sink Start Indication event.
	Flag (1 byte)	0: Accept Audio Start Streaming Request 1: Reject Audio Start Streaming Request

Table 4-112 Audio Sink Start Response Command

When the CYW207xx receives and processes this command, it attempts to accept/reject the Audio Start Request identified by the passed handle.

### 4.17.6 Audio Sink Change Route

The Audio Sink Change Route command instructs the CYW207xx to change the output data route identified by connection handle.

The MCU can send an Audio Sink Change Route command only after an audio sink connection to the peer device has been established and before audio streaming is started. This command should be sent on receiving [Audio Sink Codec Configured](#) event.

Item	Description	
Operating code	0x06	
Parameters	Connection handle (2 bytes)	The connection handle as reported in the Audio Sink Connected event.
	Route (1 byte)	0: I2S - Route the PCM Samples over I2S (Default) 1: UART - Route the PCM samples over transport 4: Compressed Transport - Route the compressed audio data over transport.

Table 4-113 Audio Sink Change Route

## 4.18 Miscellaneous Commands: HCI\_CONTROL\_GROUP\_MISC

The miscellaneous commands allow the host to send the general commands as defined by the CYW207xx.

### 4.18.1 Ping Request

This miscellaneous command sends a Ping Request to the CYW207xx. The application running on the CYW207xx is expected to respond back with a Ping Reply event (see ["Ping Request Reply"](#)). The Ping Reply event is expected to return back the data sent as part of the Ping Request.

Item	Description
Operating code	0x01
Parameters	Data (variable bytes)

*Table 4-114. Ping Request Command*

#### 4.18.2 Get Version

This miscellaneous command requests the CYW207xx to report the WICED Studio version used to build the embedded application. The application running on the CYW207xx is expected to respond back with a Version Info event (see [“Version Info”](#)).

Item	Description
Operating code	0x02

*Table 4-115. Get Version Command*

## 5 WICED HCI Control Protocol Events

### 5.1 Device Events: HCI\_CONTROL\_GROUP\_DEVICE

The device events are general events and state transitions reported by the CYW207xx.

#### 5.1.1 Command Status

The Command Status event indicates to the MCU that execution of the command has been started or that a command has been rejected due to the state of the hci\_control application.

Item	Description	
Operating code	0x01	
Parameters	Status (1 byte)	0: Execution of the command has started.
		1: The command has been rejected because the previous command is still executing.
		2: The Connect command has been rejected because the specified device is already connected.
		3: The Disconnect command has been rejected because the connection is down.
		4: The handle parameter in the command is invalid.
		5: The Discover, Read, or Write command has been rejected because the previous command has not finished executing.
		6: Invalid parameters passed in the command.
		7: Bluetooth stack on CYW207xx failed to execute the command.
		8: Embedded application loaded on the CYW207xx does not support processing of the commands of the requested group
		9: Embedded application loaded on CYW207xx does not support the command requested by the MCU.
		10: LE application cannot send notification or indication because the GATT client is not registered.
		11: Out of memory.
		12: Operation disallowed.

Table 5-1. Command Status Event

#### 5.1.2 WICED Trace

When tracing is enabled (see “Trace Enable”), the CYW207xx sends WICED\_BT\_TRACE statements over UART for the MCU to display.

Item	Description
Operating code	0x02
Parameters	WICED_BT_TRACE statements (ASCII string)

Table 5-2. WICED Trace Event

### 5.1.3 HCI Trace

When tracing is enabled (see “[Trace Enable](#)”), the CYW207xx sends binary data with the HCI commands, events, and data over UART for the MCU to display.

Item	Description	
Operating code	0x03	
Parameters	Type (1 byte)	0: HCI event 1: HCI command 2: Incoming HCI data 3: Outgoing HCI data
	Raw HCI bytes (variable bytes)	Data formatted according to the Bluetooth Core Specification Vol. 2 Part E. <a href="#">[2]</a>

Table 5-3. HCI Trace Event

### 5.1.4 NVRAM Data

For the situations when the CYW207xx does not have internal persistent storage, an application running on the CYW207xx can send data to the MCU in the NVRAM Data events.

Item	Description	
Operating code	0x04	
Parameters	nvrām_id (2 bytes)	ID of the NVRAM information chunk
	nvrām_data (variable bytes)	Data corresponding to the nvrām_id

Table 5-4. NVRAM Data Event

### 5.1.5 Device Started

The hci\_control application sends a Device Started event at the end of application initialization. Upon receiving the event, the MCU can assume that there are no active connections. The application logic determines the initial BLE scanning or advertising state and whether the Bluetooth device is discoverable and/or connectable.

Item	Description
Operating code	0x05
Parameters	-

Table 5-5. Device Started Event

### 5.1.6 Inquiry Result

The hci\_control application sends an Inquiry Result event when the CYW207xx is performing the inquiry procedure and information is received about a discoverable peer device.

Item	Description
Operating code	0x06
Parameters	Address (6 bytes)
	Class of device (CoD) (3 bytes)
	RSSI (1 byte)
	Extended inquiry response (EIR) data (variable bytes)

Table 5-6. Inquiry Result Event

### 5.1.7 Inquiry Complete

The hci\_control application sends an Inquiry Complete event on completion of the inquiry process.

Item	Description
Operating code	0x07
Parameters	-

Table 5-7. Inquiry Complete Event

### 5.1.8 Pairing Completed

The hci\_control application sends a Pairing Completed event when a secure bond with the peer device has been established or when an attempt to establish a bond has failed.

Item	Description
Operating code	0x08
Parameters	Pairing result (1 byte):  0: Success 1: Passkey Entry Failure 2: OOB Failure 3: Pairing Authentication Failure 4: Confirm Value Failure 5: Pairing Not Supported 6: Encryption Key Size Failure 7: Invalid Command 8: Pairing Failure Unknown 9: Repeated Attempts 10: Internal Pairing Error 11: Unknown I/O Capabilities 12: SMP Initialization Failure 13: Confirmation Failure 14: SMP Busy 15: Encryption Failure 16: Bonding Started 17: Response Timeout 18: Generic Failure 19: Connection Timeout
	Bluetooth device address (6 bytes)

Table 5-8. Pairing Complete Event



### 5.1.9 Encryption Changed

The hci\_control application sends an Encryption Changed event when a link to the peer device has been encrypted or when encryption has been turned off.

Item	Description	
Operating code	0x09	
Parameters	Encryption status (1 byte):	0: Encryption enabled Else: Encryption disabled
	Bluetooth device address (6 bytes)	

Table 5-9. Encryption Changed Event

### 5.1.10 Connected Device Name

The application running on the CYW207xx can send this command to inform the MCU of the friendly name of the connected device.

Item	Description
Operating code	0x0A
Parameters	A variable length UTF-8 string representing a peer's device name.

Table 5-10. Connected Device Name Event

### 5.1.11 User Confirmation Request

The application running on the CYW207xx device can be written to support numerical-comparison pairing or require a user permission to pair with another device. For these cases, the application sends this event to the MCU.

Item	Description
Operating code	0x0B
Parameters	Bluetooth device address (6 bytes)
	Numeric comparison code (4 bytes)

Table 5-11. User Confirmation Request Event

### 5.1.12 Device Error

The CYW207xx sends this event when it runs into a situation where it cannot proceed and needs to reset in order to recover. This can occur if the controller or the embedded application detects that it has entered a bad state.

Item	Description	
Operating code	0x0C	
Parameters	Application Error Code (1 byte)	Error code reported by application
	Firmware Error Code (1 byte)	Error code reported by controller

Table 5-12. Device Error Event

### 5.1.13 Local Bluetooth Device Address

The CYW207xx sends this event in response to the Read Local Bluetooth Device Address Command.

Item	Description
Operating code	0x0D
Parameters	A 6-byte Bluetooth device address

*Table 5-13. Local Bluetooth Device Address Event*

### 5.1.14 Maximum Number of Paired Devices Reached

The CYW207xx sends this event if the maximum amount of keys stored for paired devices is reached. When this event occurs, the CYW207xx will also disable pairing since there are no more buffers available to store more pairing keys. The host will need to delete one or more NVRAM entries and enable pairing in order to pair with more devices.

Item	Description
Operating code	0x0E
Parameters	-

*Table 5-14. Maximum Number of Paired Devices Reached Event*

### 5.1.15 Buffer Pool Usage Statistics

The CYW207xx sends this event when the Read Buffer Pool Usage Statistics is received. The Buffer Pool Usage Statistics event message provides the buffer pool usage since the start of the application running on the CYW207xx. This event message provides all buffer pool information such as the number of buffers allocated at the instance of receiving the Read Buffer Pool Usage Statistics command, the maximum number of buffers in use at a given time since the start of the system, and the total number of buffers in a pool. The actual number of pools are application dependent.

Item	Description
Operating code	0x0F
Parameters	Pool ID (1 byte)
	Pool Buffer Size (2 byte)
	Current Allocated Count (2 bytes)
	Maximum Allocated Count (2 bytes)
	Total Allocated Count (2 bytes)

*Table 5-15. Buffer Pool Usage Statistics Event*

## 5.2 LE Events—HCI\_CONTROL\_GROUP\_LE

The LE events are related to the LE GAP profile and reported by the CYW207xx.

### 5.2.1 LE Command Status

This event indicates to the MCU that LE command execution has started or that a command has been rejected due to the state of the hci\_control application.

Item	Description	
Operating code	0x01	
Parameters	Status (1 byte)	See “Command Status Event”

Table 5-16. LE Command Status Event

### 5.2.2 LE Scan Status

The hci\_control application sends a Scan Status event when the CYW207xx enters a new scanning state. A scanning state transition can be caused by a received LE Scan Command or internal application or stack logic.

Item	Description	
Operating code	0x02	
Parameters	State <sup>a</sup>	0 No scan
		1 High-duty-cycle scan
		2 Low-duty-cycle scan

a. The high-duty-cycle and low-duty-cycle scan parameters for each state are defined in the wiced\_bt\_cfg.c file, which is included in every application.

Table 5-17. LE Scan Status Event

### 5.2.3 LE Advertisement Report

The hci\_control application sends an LE Advertisement Report event when the CYW207xx is scanning and it receives an advertisement or a scan response from a peer device.

Item	Description
Operating code	0x03
Parameters	Event type indicating the type of advertisement report (1 byte)
	Address type indicating the Bluetooth address type (1 byte)
	Bluetooth device address (6 bytes)
	RSSI of the advertisement (1 byte)
	Advertisement data (variable bytes)

Table 5-18. LE Advertisement Report Event

## 5.2.4 LE Advertisement State

The hci\_control application sends an Advertisement State event when the CYW207xx enters a new advertisement state. An advertisement state change can be caused by an Advertisement Command received from the MCU or by internal application or stack logic.

Item	Description	
Operating code	0x04	
Parameters	State <sup>a</sup>	0 Not Discoverable
		1 High-duty-cycle discoverable
		2 Low-duty-cycle discoverable

a. The advertisement intervals and durations for each state are defined in the wiced\_bt\_cfg.c file, which is included in every application.

Table 5-19. LE Advertisement State Event

## 5.2.5 LE Connected

The hci\_control application sends the LE Connected event when the CYW207xx establishes a connection with a peer Bluetooth LE device identified by address type and address. The connection handle identifies the connection and can be used in consecutive requests to disconnect or transfer data. If the Role parameter is zero, then the CYW207xx is a Master/Central in a newly established connection. Otherwise, the CYW207xx performs as a Slave/Peripheral. If the CYW207xx is performing as a GATT client, then the MCU can issue the GATT Command Read Request, GATT Command Write, or GATT Command Write Request commands to send data to the peer. Otherwise, the GATT Command Notify or GATT Command Indicate commands should be used.

Item	Description	
Operating code	0x05	
Parameters	Type (1 byte)	Bluetooth-device address type.
	Address (6 bytes)	Bluetooth-device address
	Connection handle (2 bytes)	This is the connection handle reported in the LE Connected event.
	Role (1 byte)	The role is either peripheral or central.

Table 5-20. LE Connected Event

## 5.2.6 LE Disconnected

When the Bluetooth LE connection with a peer device is disconnected, the hci\_control application sends the LE Disconnected event. The connection handle and disconnection reason are passed as parameters.

Item	Description	
Operating code	0x06	
Parameters	Connection handle (2 bytes)	This is the connection handle reported in the LE Connected event.
	Disconnection reason (1 byte)	-

Table 5-21. LE Disconnected Event

### 5.2.7 LE Identity Address

When the LE Get Identity Address is called, the resolved Identity Address of the peer is returned via this event message.

Item	Description	
Operating code	0x07	
Parameters	Address (6 bytes)	Resolved Identity address

Table 5-22. LE Identity Address Event

### 5.2.8 LE Peer MTU

When the CYW207xx receives a Client MTU Request, this event will be passed to the MCU indicating the negotiated MTU size.

Item	Description	
Operating code	0x08	
Parameters	Connection handle (2 bytes)	This is the connection handle reported in the LE Connected event
	MTU size (2 bytes)	

Table 5-23. LE Peer MTU Event

### 5.2.9 LE Connection Parameters

When the CYW207xx receives a connection update complete event from a peer device, this LE Connection Parameters event will be passed to the MCU indicating the negotiated connection parameters or error code reflected by the Status byte.

Item	Description	
Operating code	0x09	
Parameters	Status (1 byte)	0: Success, Else: Failure
	Peer Address (6 bytes)	
	Connection Interval (2 bytes)	
	Connection Latency (2 bytes)	
	Supervision Timeout (2 bytes)	

Table 5-24. LE Connection Parameters Event

## 5.3 GATT Events

The GATT events are related to the GATT profile and reported by the CYW207xx.

### 5.3.1 GATT Command Status

This event indicates to the MCU that GATT command execution has started or that a command has been rejected due to the state of the hci\_control application.

Item	Description	
Operating code	0x01	
Parameters	Status (1 byte)	See "Command Status Event"

Table 5-25. GATT Command Status Event

### 5.3.2 GATT Discovery Complete

The GATT Discovery Complete event indicates to an MCU that all results from a previously issued GATT Discover Services, GATT Discover Characteristics, or GATT Discover Descriptors command have been delivered. After receiving this event, the MCU can start a new discovery procedure.

Item	Description	
Operating code	0x02	
Parameters	Connection handle (2 bytes)	This is the connection handle reported in the LE Connected event.

Table 5-26. GATT Discovery Complete Event

### 5.3.3 GATT Service Discovered

While performing a service discovery, the hci\_control application sends the GATT Service Discovered event for every service found on a peer device. The connection handle identifies the connection to the peer device. The start and end handles identify the handles used by the service. The UUID identifies the remote service and can be either 2 or 16 bytes.

Item	Description	
Operating code	0x03	
Parameters	Connection handle (2 bytes)	This is the connection handle reported in the LE Connected event.
	UUID (2 or 16 bytes)	The UUID of the discovered service.
	Start handle (2 bytes)	The start handle of the service.
	End handle (2 bytes)	The end handle of the service.

Table 5-27. GATT Service Discovered Event

### 5.3.4 GATT Characteristic Discovered

While performing a characteristic discovery, the hci\_control application sends the GATT Characteristic Discovered event for every characteristic discovered on the peer device. The connection handle identifies the connection to the peer device. The value handle can be used by the MCU in consecutive GATT Read, GATT Write Command, GATT Write Request, GATT Notify, or GATT Indicate calls to send data to the peer. The UUID identifies the remote characteristic and can be either 2 or 16 bytes.

Item	Description	
Operating code	0x04	
Parameters	Connection handle (2 bytes)	This is the connection handle reported in the LE Connected event.
	Characteristic handle (2 bytes)	-
	UUID (2 or 16 bytes)	The UUID of the characteristic found.
	Characteristic properties (1 byte)	A bit mask of the properties supported by the discovered characteristic.
	Value handle (2 bytes)	The characteristic-value handle that can be used in consecutive reads and write.

Table 5-28. GATT Characteristic Discovered Event

### 5.3.5 GATT Descriptor Discovered

While performing a characteristic descriptor discovery, the hci\_control application sends the GATT Descriptor Discovered event for every characteristic descriptor discovered on the peer device. The connection handle identifies the connection to the peer device. The handle can be used by the MCU in consecutive GATT Read or GATT Write Request commands to set or get a descriptor value. The UUID identifies the remote descriptor and can be either 2 or 16 bytes

Item	Description	
Operating code	0x05	
Parameters	Connection handle (2 bytes)	This is the connection handle reported in the LE Connected event.
	UUID (2 or 16 bytes)	The descriptor UUID.
	Handle (2 bytes)	The descriptor handle, which can be used in subsequent reads and writes.

Table 5-29. GATT Descriptor Discovered Event

### 5.3.6 GATT Event Read Request

The GATT Event Read Request can be sent to the MCU to provide the value of the specific attribute. The connection handle identifies the connection to the peer device requesting the operation and the attribute handle identifies the attribute requested by the peer device. Upon receiving this request, the MCU should send the GATT Command Read Response (see “GATT Command Read Response”).

Item	Description	
Operating code	0x06	
Parameters	Connection handle (2 bytes)	This is the connection handle reported in the LE Connected event.
	Attribute handle (2 bytes)	The attribute handle of the value being read.

Table 5-30. GATT Event Read Request

See [Figure 4-4 Reading a Dynamic Attribute from a Peer](#) for a message sequence example where the GATT Event Read Request is used.

### 5.3.7 GATT Event Read Response

The GATT Event Read Response indicates to the MCU that the execution of the GATT Command Read Request has completed. The event includes the received data. The connection handle identifies the connection to the peer device for which the read procedure has been performed.

Item	Description	
Operating code	0x07	
Parameters	Connection handle (2 bytes)	This is the connection handle reported in the LE Connected event.
	Data (variable bytes)	-

Table 5-31. GATT Event Read Response

See [Figure 4-3 Reading a Static Attribute from a Peer](#) and [Figure 4-4 Reading a Dynamic Attribute from a Peer](#) for message sequence examples where the GATT Event Read Response is used.

### 5.3.8 GATT Event Write Request

The GATT Event Write Request indicates to the MCU that a write request from a connected peer has been received. The connection handle identifies the connection of the peer device that issued the write request and the attribute handle identifies the characteristic to be written.

The CYW207xx application can be designed to wait for the GATT Command Write Response (see “GATT Command Write Response”) or to reply automatically to indicate the success of the write operation to the peer. Waiting for the GATT Command Write Response is required when the MCU needs to be able to reject peer write attempts.

Item	Description	
Operating code	0x08	
Parameters	Connection handle (2 bytes)	This is the connection handle reported in the LE Connected event.
	Attribute handle (2 bytes)	The attribute handle of the value being written.
	Data (variable bytes)	-

Table 5-32. GATT Event Write Request

See [Figure 4-7. GATT Command Write Request – MCU Is Involved in a Write](#) for a message sequence example where the GATT Event Write Request is used.



### 5.3.9 GATT Event Write Response

The GATT Event Write Response indicates to the MCU that the execution of a GATT Command Write, GATT Command Write Request, GATT Command Notify, or GATT Command Indicate has completed. The event includes the result of the write operation. The connection handle identifies the connection to the peer device for which the procedure has been performed.

For the GATT Command Write Request and GATT Command Indicate commands, issuance of the GATT Event Write Response indicates that the write has completed and that the peer has confirmed receiving the data. For the GATT Command Write and GATT Command Notify commands, issuance of the GATT Event Write Response indicates that the buffer has been allocated and a command has been scheduled for transmission.

Item	Description	
Operating code	0x09	
Parameters	Connection handle (2 bytes)	This is the connection handle reported in the LE Connected event.
	Result (1 byte)	-

Table 5-33. GATT Event Write Response

See [Figure 4-7. GATT Command Write Request – MCU Is Involved in a Write](#) for a message sequence example where the GATT Event Write Response is used.

### 5.3.10 GATT Event Indication

The GATT Event Indication event passes data received from a peer-sent GATT Indication to the MCU. The connection handle identifies the connection to the peer device from which the GATT Indication was received. The attribute handle identifies the characteristic value or descriptor to which data has been written.

The application running on the CYW207xx can behave in one of the following two ways after receiving a GATT Indication:

- It can reply automatically (with the success).
- In a flow-controlled scenario, it can pass the event up to the MCU and wait for the GATT Command Indicate Confirm from the MCU before replying.

Item	Description	
Operating code	0x0A	
Parameters	Connection handle (2 bytes)	This is the connection handle reported in the LE Connected event.
	Attribute handle (2 bytes)	This the handle of the attribute being accessed.
	Data (variable bytes)	-

Table 5-34. GATT Event Indication Event

See [Figure 4-9. GATT Command Indicate Message Sequence](#) for a message sequence example where the GATT Event Indication is used.

### 5.3.11 GATT Event Notification

The GATT Event Notification forwards data received from a peer-sent GATT Command Notify to the MCU. The connection handle identifies the connection to the peer device from which the GATT Command Notify was received. The attribute handle identifies the characteristic value to which data has been written.

Item	Description	
Operating code	0x0B	
Parameters	Connection handle (2 bytes)	This is the connection handle reported in the LE Connected event.
	Attribute handle (2 bytes)	This is the handle of the attribute being accessed.

Table 5-35. GATT Event Notification Event

See [Figure 4-8. GATT Command Notify Message Sequence](#) for a message sequence example where the GATT Event Notification is used.

### 5.3.12 GATT Event Read Error

The GATT Event Read Error message will be sent to the MCU in the case where a GATT Read Request command resulted in an error. This event message will include the received read result GATT error code, e.g. Insufficient Authentication.

Item	Description	
Operating code	0x0C	
Parameters	Connection handle (2 bytes)	This is the connection handle reported in the LE Connected event.
	Read result (1 byte)	Received GATT error code.

Table 5-36. GATT Event Read Error

### 5.3.13 GATT Event Write Request Error

The GATT Event Write Request Error message will be sent to the MCU in the case where a GATT Write Request command resulted in an error. This event message will include the received read result GATT error code, e.g. Insufficient Authentication.

Item	Description	
Operating code	0x0D	
Parameters	Connection handle (2 bytes)	This is the connection handle reported in the LE Connected event.
	Read result (1 byte)	Received GATT error code.

Table 5-37. GATT Event Write Request Error

## 5.4 HF Events: HCI\_CONTROL\_GROUP\_HF

These events sent by the CYW207xx pertain to the functionality of the Hands-Free profile.

### 5.4.1 HF Open

This event is sent when an RFCOMM connection is established with an AG. At this point, the Service Level Connection (SLC) is still not established, so commands cannot yet be sent. The Bluetooth device address and connection handle are passed as parameters. The connection handle can be used by the MCU to send commands or to identify a peer device that caused the event.

Item	Description
Operating code	0x01
Parameters	Connection handle (2 bytes)
	Bluetooth device address of the AG (6 bytes)
	Status (1 byte)

Table 5-38. HF Open Event

### 5.4.2 HF Close

This event is sent when an RFCOMM connection with an AG is closed.

Item	Description
Operating code	0x02
Parameters	Connection handle (2 bytes)

Table 5-39. HF Close Event

### 5.4.3 HF Connected

This event is sent when the hands-free device and the AG have completed the protocol exchange necessary to establish an SLC. At this point, the application can send any commands to the CYW207xx.

Item	Description
Operating code	0x03
Parameters	Connection handle (2 bytes)
	32-bit mask of AG supported features

Table 5-40. HF Connected Event

### 5.4.4 HF Audio Open

This event is sent when an audio connection with an AG is opened.

Item	Description
Operating code	0x04
Parameters	Connection handle (2 bytes)

Table 5-41. HF Audio Open Event

### 5.4.5 HF Audio Close

This event is sent when an audio connection with an AG is closed.

Item	Description
Operating code	0x05
Parameters	Connection handle (2 bytes)

Table 5-42. HF Audio Close Event

### 5.4.6 HF Audio Connection Request

This event is sent to the MCU on receiving an audio connection request from the AG. The MCU shall use the [HF Accept/Reject Audio Connection](#) command to accept/reject the connection request.

Item	Description
Operating code	0x06
Parameters	Bluetooth device address of the AG (6 bytes)
	SCO Index (2 bytes)

Table 5-43. HF Audio Connection Request Event

### 5.4.7 HF Response

The HF Response events are sent when a response is received from the AG for a command sent by the application.

Item	Description
Operating code	See <a href="#">Table 5-45. HF Response Event Details</a>
Parameters	Connection handle (2 bytes)
	Numeric value (2 bytes)
	Optional supporting character string

Table 5-44. HF Response Event Format

[Table 5-45](#) shows various available values for the operating code, numeric value, and optional string parameters of [Table 5-44](#)

Operating Code		Numeric Value	Optional String
Code	Description		
0x20	OK response	Command index of last command	-
0x21	Error response	Command index of last command	-
0x22	Extended error response	Command index of last command	Error code
0x23	Incoming call	-	-
0x24	Speaker gain	0–15	-
0x25	Microphone gain	0–15	-
0x26	Incoming call waiting	-	The calling party's number and number type. For example: "nnnnn, 128"
0x27	Call hold	0: Release all held calls	-

Operating Code		Numeric Value	Optional String
Code	Description		
		1: Release all active calls 2: Swap active and held calls 3: Hold active call	
0x28	AG indicators	-	The AG indicators
0x29	Caller phone number	-	The caller's number
0x2A	AG indicator changed	-	The indicator number [1-7] and value. For example: "1,2" 1: Service indicator 2: Call status indicator 3: Call set up status indicator 4: Call hold status indicator 5: Signal Strength indicator 6: Roaming status indicator 7: Battery Charge indicator
0x2B	Number attached to voice tag	-	Phone number. For example: "nnnnnn"
0x2C	Voice recognition status	0: VR disabled in AG 1: VR enabled in AG	-
0x2D	In-band ring tone	0: No AG in-band ring tone 1: AG provides in-band ring tone	-
0x2E	Subscriber number	-	The subscriber number and number type. For example: "nnnnn, 128"
0x2F	Call hold status	0: AG put incoming call on hold 1: AG accepted held incoming call 2: AG rejected held incoming call	-
0x30	Operator information	-	-
0x31	Active call list	-	List of active calls
0x32	Supported HF indicators	-	-
0x33	Bluetooth Codec Selection	1: CVSD Codec 2: MSBC Codec	-
0x34	Unknown AT response	-	The unknown response that was received from the AG.

Table 5-45. HF Response Event Details

## 5.5 SPP Events— HCI\_CONTROL\_GROUP\_SPP

These events sent by the CYW207xx pertain to the functionality of the Serial Port Profile (SPP).

### 5.5.1 SPP Connected

This event is sent when an SPP connection has been established with a peer device. The Bluetooth device address and connection handle are passed as parameters. The connection handle can be used by the MCU for future commands to send commands or data and to identify a peer device that has sent data.

Item	Description
Operating code	0x01
Parameters	Bluetooth device address (6 bytes)
	Connection handle (2 bytes)

Table 5-46. SPP Connected Event

### 5.5.2 SPP Service Not Found

This event is sent when a CYW207xx is able to connect to a peer device and perform SDP discovery, but the SPP service is not found.

Item	Description
Operating code	0x02
Parameters	-

Table 5-47. SPP Service Not Found Event

### 5.5.3 SPP Connection Failed

A CYW207xx sends this event when a connection attempt requested by an MCU is unsuccessful.

Item	Description
Operating code	0x03
Parameters	-

Table 5-48. SPP Connection Failed Event

### 5.5.4 SPP Disconnected

This event is sent when an SPP connection has been dropped.

Item	Description
Operating code	0x04
Parameters	Connection handle (2 bytes)

Table 5-49. SPP Disconnected Event

### 5.5.5 SPP TX Complete

A CYW207xx sends this event after a data packet received from an MCU, in an SPP Send Data command, has been queued for transmission. The MCU should not send another data packet until it has received this event for the previous packet.

Item	Description
Operating code	0x05
Parameters	Connection handle (2 bytes)
	Result (1 byte) 0 = Success, other result codes defined in WICED Studio header file <code>wiced_bt_rfcomm.h</code> <code>wiced_bt_rfcomm_result_t</code> enum

Table 5-50. SPP TX Complete Event

### 5.5.6 SPP RX Data

A CYW207xx forwards SPP data received from a peer device in the SPP RX Data event.

Item	Description
Operating code	0x06
Parameters	Connection handle (2 bytes)
	Data received from the peer

Table 5-51. SPP RX Data Event

### 5.5.7 SPP Command Status

This event indicates to the MCU that a SPP command execution has started or that a command has been rejected due to the state of the `hci_control` application.

Item	Description
Operating code	0x07
Parameters	Status (1 byte)
	See "Command Status Event".

Table 5-52. SPP Command Status Event

## 5.6 Audio Events—HCI\_CONTROL\_GROUP\_AUDIO

These events sent by the CYW207xx pertain to audio (A2DP) profile functionality.

### 5.6.1 Audio Command Status

This event indicates to the MCU that an Audio command execution has started or that a command has been rejected due to the state of the hci\_control application.

Item	Description
Operating code	0x01
Parameters	Status (1 byte)
	See “Command Status Event”.

Table 5-53. Audio Command Status Event

### 5.6.2 Audio Connected

This event is sent when an audio connection has been established with a peer device. The Bluetooth device address and connection handle are passed as parameters. The connection handle can be used by the MCU to send commands or data, and to identify a peer device that has sent data.

The *Absolute Volume Capable* flag indicates to the MCU whether a peer device can accept commands to set the volume.

Item	Description	
Operating code	0x02	
Parameters	Address (6 bytes)	Bluetooth device address of peer.
	Connection handle (2 bytes)	The handle to use during command and data exchanges.
	Absolute volume capable (1 byte)	1: Peer can accept commands to set volume. 0: Peer cannot accept commands to set volume.
	A2DP Features Flags (2 bytes)	The bitmap of the supported features published in the A2DP service of the connected AV sink device. Note that publishing of the features is optional. A value of zero indicates that the AV sink does not publish the features in the SDP record.

Table 5-54. Audio Connected Event



### 5.6.3 Audio Service Not Found

A CYW207xx sends this event when it is able to connect to a peer device and perform SDP discovery, but there is no A2DP service.

Item	Description
Operating code	0x03
Parameters	-

Table 5-55. Audio Service Not Found Event

### 5.6.4 Audio Connection Failed

A CYW207xx sends this event when a connection attempt requested by the MCU is unsuccessful.

Item	Description
Operating code	0x04
Parameters	-

Table 5-56. Audio Connection Failed Event

### 5.6.5 Audio Disconnected

A CYW207xx sends this event when an audio connection has been dropped.

Item	Description
Operating code	0x05
Parameters	Connection handle (2 bytes)

Table 5-57. Audio Disconnected Event

### 5.6.6 Audio Data Request

A CYW207xx sends this event when an audio stream is configured to send audio data over UART. The host is expected to maintain and send the number of packets requested as well as the number of bytes per packet.

Item	Description	
Operating code	0x06	
Parameters	Bytes per packet (2 bytes)	
	Number of packets (1 byte)	
	Total Number of packets requested (2 bytes)	Total number of audio packets requested since the start of audio streaming, including the current Number of packets request
	Total Number of packets received (2 bytes)	Total number of audio packets received from the MCU

Table 5-58. Audio Data Request Event

### 5.6.7 Audio Started

A CYW207xx sends this event when an audio stream has been started by an MCU-sent Audio Start command (see “Audio Start”).

Item	Description
Operating code	0x07
Parameters	Connection handle (2 bytes)

Table 5-59. Audio Started Event

### 5.6.8 Audio Stopped

A CYW207xx sends this event when an audio stream has been stopped by an MCU-sent Audio Stop command (see “Audio Stop”).

Item	Description
Operating code	0x08
Parameters	Connection handle (2 bytes)

Table 5-60. Audio Stopped Event

## 5.7 AV Remote Control Controller Events: HCI\_CONTROL\_GROUP\_AVRC\_CONTROLLER

### 5.7.1 AVRC Controller Connected

A CYW207xx sends the AVRC Connected event to an MCU when a peer device establishes an AVRC connection or after a connection requested by an AVRC Connect command has been successfully established.

Item	Description	
Operating code	0x01	
Parameters	bd_addr (6 bytes)	Bluetooth address of the connected player.
	Status (1 byte)	Status of the connection establishment event. If 0, then the connection has been established successfully.
	Session handle (2 bytes)	The session handle as reported in the AVRC Connected event.

Table 5-61. AVRC Controller Connected Event

### 5.7.2 AVRC Controller Disconnected

A CYW207xx sends the AVRC Disconnected event to an MCU to indicate that the AVRC connection has been terminated.

Item	Description	
Operating code	0x02	
Parameters	Session handle (2 bytes)	The session handle as reported in the AVRC Connected event.

Table 5-62. AVRC Controller Disconnected Event

### 5.7.3 AVRC Controller Current Track Info

A CYW207xx sends this event when it receives information about new attributes of the track playing on the connected player. Each attribute reported by the player will be passed to the MCU in a separate AVRC Current Track Info event.

Item	Description	
Operating code	0x03	
Parameters	Session handle (2 bytes)	The session handle as reported in the AVRC Connected event (see <a href="#">"AVRC Controller Connected"</a> ).
	Status (1 byte)	AVRC Response Status
	Attribute ID (1 byte)	1: Title 2: Artist 3: Album 4: Track number 5: Number of tracks 6: Genre 7: Playing time
	Attribute length (2 bytes)	The length of the attribute data string.
	Data (variable bytes)	Attribute data string.

Table 5-63. AVRC Controller Current Track Info Event

### 5.7.4 AVRC Controller Play Status

A CYW207xx sends the AVRC Play Status event when a connected player reports a change in player status.

Item	Description	
Operating code	0x04	
Parameters	Session handle (2 bytes)	The session handle as reported in the AVRC Connected event (see <a href="#">"AVRC Controller Connected"</a> ).
	Play status (1 byte)	0: Stopped 1: Playing 2: Paused 3: Forward seek 4: Reverse seek 255: Error

Table 5-64. AVRC Controller Play Status Event

### 5.7.5 AVRC Controller Play Position

A CYW207xx sends an AVRC Play Status event when a connected player reports a change in the play position.

Item	Description	
Operating code	0x05	
Parameters	Session handle (2 bytes)	The session handle as reported in the AVRC Connected event (see <a href="#">"AVRC Controller Connected"</a> ).
	Play position (4 bytes)	The play position in milliseconds since the beginning of the track.

Table 5-65. AVRC Controller Play Position Event

### 5.7.6 AVRC Controller Track Change

A CYW207xx sends an AVRC Track Changed event when a connected player reports a track change. It is incumbent upon the MCU to request the updated track information.

Item	Description	
Operating code	0x06	
Parameters	Session handle (2 bytes)	The session handle as reported in the AVRC Connected event (see <a href="#">"AVRC Controller Connected"</a> ).

Table 5-66. AVRC Controller Track Change Event

### 5.7.7 AVRC Controller Track End

A CYW207xx sends an AVRC Track End event when a connected player reports reaching the end of a track.

Item	Description	
Operating code	0x07	
Parameters	Session handle (2 bytes)	The session handle as reported in the AVRC Connected event (see <a href="#">"AVRC Controller Connected"</a> ).

Table 5-67. AVRC Controller Track End Event

### 5.7.8 AVRC Controller Track Start

A CYW207xx sends an AVRC Track Start event when a connected player reports starting a new track.

Item	Description	
Operating code	0x08	
Parameters	Session handle (2 bytes)	The session handle as reported in the AVRC Connected event (see <a href="#">"AVRC Controller Connected"</a> ).

Table 5-68. AVRC Controller Track Start Event

### 5.7.9 AVRC Controller Settings Available

A CYW207xx sends an AVRC Settings Available event to report the player settings available for the connected player.

Item	Description	
Operating code	0x09	
Parameters	Session handle (2 bytes)	The session handle as reported in the AVRC Connected event (see "AVRC Controller Connected").
	Settings (variable bytes)	<p>An array of bytes indicating which attributes are supported by the connected player. Any value set in these bytes indicates that the setting is supported. The bits indicate the possible values for each setting:</p> <p>1: The player supports an Equalizer.</p> <ul style="list-style-type: none"> <li>Bit 0: Unused</li> <li>Bit 1: Off supported</li> <li>Bit 2: On supported</li> </ul> <p>2: The player supports Repeat mode.</p> <ul style="list-style-type: none"> <li>Bit 0: Unused</li> <li>Bit 1: Off supported</li> <li>Bit 2: Single Track repeat supported</li> <li>Bit 3: All Track repeat supported</li> <li>Bit 4: Group repeat supported</li> </ul> <p>3: The player supports Shuffle mode.</p> <ul style="list-style-type: none"> <li>Bit 0: Unused</li> <li>Bit 1: Off supported</li> <li>Bit 2: All Track shuffle supported</li> <li>Bit 4: Group shuffle supported</li> </ul> <p>4: The player supports Scan mode.</p> <ul style="list-style-type: none"> <li>Bit 0: Unused</li> <li>Bit 1: Off supported</li> <li>Bit 2: All track scan supported</li> </ul>

Table 5-69. AVRC Controller Settings Available Event

### 5.7.10 AVRC Controller Setting Change

A CYW207xx sends an AVRC Setting Change event to report the initial value or a settings change on a connected player.

Item	Description	
Operating code	0x0A	
Parameters	Session handle (2 bytes)	The session handle as reported in the AVRC Connected event (see "AVRC Controller Connected").
	Number of Settings (1 byte)	Number of ID-Value Pairs
	Setting ID (1 byte)	The following values indicate the ID of the player setting: 1: Equalizer. 2: Repeat mode. 3: Shuffle mode. 4: Scan mode.
	Setting value (1 byte)	For ID = 1 (Equalizer): 1: On 2: Off For ID = 2 (Repeat mode): 1: Off 2: Repeat a single track 3: Repeat all tracks 4: Repeat a group of tracks For ID = 3 (Shuffle mode): 1: Off 2: Shuffle all tracks 3: Shuffle a group of tracks For ID = 4 (Scan mode): 1: Off 2: Scan all tracks 3: Scan a group of tracks

Table 5-70. AVRC Controller Setting Change Event

### 5.7.11 AVRC Controller Player Change

A CYW207xx sends an AVRC Player change event to report a change in the named connected player.

Item	Description
Operating code	0x0B
Parameters	Name (n bytes). Character string that identifies the player by name.

Table 5-71. AVRC Controller Player Change Event

### 5.7.12 AVRC Controller Command Status

This event indicates to the MCU that an AVRC command execution has started or that a command has been rejected due to the state of the hci\_control application.

Item	Description
Operating code	0xFF
Parameters	Status (1 byte). See "Command Status Event".

Table 5-72. AVRC Controller Command Status Event

## 5.8 AV Remote Control Target Events: HCI\_CONTROL\_GROUP\_AVRC\_TARGET

### 5.8.1 AVRC Target Connected

A CYW207xx device sends the AVRC Connected event to an MCU when a peer device establishes an AVRC connection or after a connection requested by an AVRC Connect command has been successfully established.

Item	Description	
Operating code	0x01	
Parameters	bd_addr (6 bytes).	Bluetooth address of the connected player.
	Session handle (2 bytes)	The session handle as reported in the AVRC Connected event.

Table 5-73. AVRC Target Connected Event

### 5.8.2 AVRC Target Disconnected

A CYW207xx sends the AVRC Disconnected event to an MCU to indicate that the AVRC connection has been terminated.

Item	Description	
Operating code	0x02	
Parameters	Session handle (2 bytes).	The session handle as reported in the AVRC Connected event.

Table 5-74. AVRC Target Disconnected Event

### 5.8.3 AVRC Target Play

The CYW207xx sends this event to the MCU when a play command is received from a connected AVRC controller.

Item	Description
Operating code	0x03
Parameters	Connection handle (2 bytes)

Table 5-75. AVRC Target Play Event

### 5.8.4 AVRC Target Stop

The CYW207xx sends this event to the MCU when a stop command is received from a connected AVRC controller.

Item	Description
Operating code	0x04
Parameters	Connection handle (2 bytes)

Table 5-76. AVRC Target Stop Event

### 5.8.5 AVRC Target Pause

The CYW207xx sends this event to the MCU when a pause command is received from a connected AVRC controller.

Item	Description
Operating code	0x05
Parameters	Connection handle (2 bytes)

Table 5-77. AVRC Target Pause Event

### 5.8.6 AVRC Target Next Track

The CYW207xx sends this event to the MCU when a next track command is received from a connected AVRC controller.

Item	Description
Operating code	0x06
Parameters	Connection handle (2 bytes)

Table 5-78. AVRC Target Next Track Event

### 5.8.7 AVRC Target Previous Track

The CYW207xx sends this event to the MCU when a previous track command is received from a connected AVRC controller.

Item	Description
Operating code	0x07
Parameters	Connection handle (2 bytes)

Table 5-79. AVRC Target Previous Track Event

### 5.8.8 AVRC Target Begin Fast Forward

The CYW207xx sends this event to the MCU when a connected AVRC controller starts fast-forward operation. The target application should continue the fast forward operation until the End Fast Forward event is received.

Item	Description
Operating code	0x08
Parameters	Connection handle (2 bytes)

Table 5-80. AVRC Target Begin Fast Forward Event



### 5.8.9 AVRC Target End Fast Forward

The CYW207xx sends this event to the MCU when a connected AVRC controller terminates fast-forward operation.

Item	Description
Operating code	0x09
Parameters	Connection handle (2 bytes)

Table 5-81. AVRC Target End Fast Forward Event

### 5.8.10 AVRC Target Begin Rewind

The CYW207xx sends this event to the MCU when a connected AVRC controller starts rewind operation. The MCU should continue the Rewind operation until the End Rewind event is received.

Item	Description
Operating code	0x0A
Parameters	Connection handle (2 bytes)

Table 5-82. AVRC Target Begin Rewind Event

### 5.8.11 AVRC Target End Rewind

The CYW207xx sends this event to the MCU when a connected AVRC controller terminates rewind operation.

Item	Description
Operating code	0x0B
Parameters	Connection handle (2 bytes)

Table 5-83. AVRC Target End Rewind Event

### 5.8.12 AVRC Target Volume Level

The CYW207xx sends this event to the MCU when it receives a volume-level indication from a connected AVRC controller.

Item	Description
Operating code	0x0C
Parameters	Connection handle (2 bytes)
	Volume level (1 byte). The percentage (0 to 100) of the maximum volume level of the local audio player to be set.

Table 5-84. AVRC Target Volume Level Event

### 5.8.13 AVRC Target Repeat Settings

The CYW207xx sends this event to the MCU when a connected remote controller changes the player repeat attribute settings value.

Item	Description	
Operating code	0x0D	The following are possible values:
Parameters	Setting value (1 byte)	0x01: Off
		0x02: Single Track Repeat
		0x03: All Track Repeat
		0x04: Group Repeat

Table 5-85. AVRC Target Repeat Settings Event

### 5.8.14 AVRC Target Shuffle Settings

The CYW207xx sends this event to the MCU when a connected remote controller changes the player shuffle attribute settings value.

Item	Description	
Operating code	0x0E	The following are possible values:
Parameters	Setting value (1 byte)	0x01: Off
		0x02: All Track Shuffle
		0x03: Group Shuffle

Table 5-86. AVRC Target Shuffle Event

### 5.8.15 AVRC Target Command Status

This event indicates to the MCU that an AVRC command execution has started or that a command has been rejected due to the state of the hci\_control application.

Item	Description	
Operating code	0xFF	The following are possible values:
Parameters	Status (1 byte)	See " <a href="#">Command Status Event</a> "

Table 5-87. AVRC Target Command Status Event

## 5.9 HID Device Events: HCI\_CONTROL\_GROUP\_HIDD

These events sent by the CYW207xx pertain to HID device profile functionality.

### 5.9.1 HID Opened

This event is sent when a HID connection has been fully established with a peer device, including control and interrupt channels.

Item	Description
Operating code	0x01
Parameters	-

Table 5-88. HID Opened Event

### 5.9.2 HID Virtual Cable Unplugged

The CYW207xx sends this event when a connected host sends a Virtual Cable Unplug message over the HID control channel.

Item	Description
Operating code	0x02
Parameters	-

Table 5-89. HID Virtual Cable Unplugged Event

### 5.9.3 HID Data

The CYW207xx sends a HID data event after receiving a HID report on either the control or interrupt channel.

Item	Description
Operating code	0x03
Parameters	Report type (1 byte)
	Report data (variable bytes)

Table 5-90. HID Data Event

### 5.9.4 HID Closed

The CYW207xx sends this event when a HID connection has been disconnected.

Item	Description
Operating code	0x04
Parameters	Reason (1 byte)

Table 5-91. HID Closed Event

## 5.10 AIO Server Events: HCI\_CONTROL\_GROUP\_AIO\_SERVER

These events sent by a CYW207xx pertain to AIO server functionality.

### 5.10.1 AIO Digital Output

This event sends a digital output value to an MCU.

Item	Description	
Operating code	0x01	
Parameters	Index (1 byte)	Digital IO index, starting with 0.
	Data (variable bytes)	An array of 2-bit values in a bit field in little endian order.

Table 5-92. AIO Digital Output Event

### 5.10.2 AIO Analog Output

This event sends an analog output value to an MCU.

Item	Description	
Operating code	0x02	
Parameters	Index (1 byte)	Analog IO index, starting with 0.
	Data (2 bytes)	The value of the analog signal as an unsigned 16-bit integer.

Table 5-93. AIO Analog Output Event

## 5.11 AIO Client Events: HCI\_CONTROL\_GROUP\_AIO\_CLIENT

These events sent by a CYW207xx pertain to AIO client functionality.

### 5.11.1 AIO Command Status

This event indicates to an MCU that AIO command execution has started or that a command was rejected due to the state of the application.

Item	Description	
Operating code	0x01	
Parameters	Status (1 byte)	0: Command execution has started. 1: Command rejected because the previous command is still executing. 2: Connect command rejected; the specified device is already connected. 3: Disconnect command rejected because the connection is down. 4: Characteristic is not found. 5: Characteristic Descriptor is not found. 6: Invalid parameters passed in the command

Table 5-94. AIO Command Status Event

### 5.11.2 AIO Connected

This event instructs an MCU that a connection with an AIO server had been created.

Item	Description
Operating code	0x02
Parameters	Device address (6 bytes)

Table 5-95. AIO Connected Event

### 5.11.3 AIO Read Response

This event sends a read response to an MCU.

Item	Description	
Operating code	0x03	
Parameters	Status (1 byte)	0: Success. 2: Read not permitted.
	Data (variable bytes)	An unsigned 16-bit integer for analog IO or an array of 2-bit values in a bit field for digital IO.

Table 5-96. AIO Read Response Event

### 5.11.4 AIO Write Response

This event sends a write response to an MCU.

Item	Description	
Operating code	0x04	
Parameters	Status (1 byte)	0: Success. 3: Write not permitted.
	Data (variable bytes)	An unsigned 16-bit integer for analog IO or an array of 2-bit values in a bit field for digital IO.

Table 5-97. AIO Write Response Event

### 5.11.5 AIO Input

The AIO client sends this event to an MCU after it receives notification about an IO module input change on the server.

Item	Description	
Operating code	0x05	
Parameters	Type (1 byte)	1: Analog IO. 2: Digital IO.
	Index (1 byte)	Analog or digital IO index, starting with 0.
	Data (variable bytes)	An unsigned 16-bit integer for analog IO or an array of 2-bit values in a bit field for digital IO.

Table 5-98. AIO Input Event

### 5.11.6 AIO Disconnected

This event informs an MCU that an AIO server has been disconnected.

Item	Description
Operating code	0x06
Parameters	Reason (1 byte)

Table 5-99. AIO Disconnected Event

## 5.12 Current Time Events: HCI\_CONTROL\_GROUP\_TIME

### 5.12.1 Time Update

An application running on a CYW207xx sends this event to an MCU when it can to connect to a peer device and retrieve the current time via a current-time service or when a current-time service running on a peer device sends a time update notification (for example, a notification that daylight savings time [DST] has taken effect).

The date and time values are the local date and time reported by the server device. The time the server device provides is normally the correct time for the location adjusted for time zone and DST.

Item	Description	
Operating code	0x01	
Parameters	Year (2 bytes)	Current year
	Month (1 byte)	Current month
	Day (1 bytes)	Current day of month
	Hour (1 byte)	Current hour
	Minutes (1 byte)	Current minutes
	Seconds (1 byte)	Current seconds
	Exact time 256 (1 byte)	Current seconds fraction. LSB = 1/256 seconds.
	Day of week (1 byte)	Current day of the week: 1: Monday 2: Tuesday 3: Wednesday 4: Thursday 5: Friday 6: Saturday 7: Sunday
Adjust Reason (1 byte)	Bit field indicating the reason for the change in the time on the server. Bit 0: Manual time update Bit 1: External reference time update Bit 2: Time zone change Bit 3: Daylight savings time change	

Table 5-100. Time Update Event

## 5.13 Test Events: HCI\_CONTROL\_GROUP\_TEST

The Test events pertain to the Test command functionality to allow the host to execute various tests on the CYW207xx.

### 5.13.1 Encapsulated HCI Event

While in the Test Mode, the application encapsulates all the HCI Events received from the controller in the Encapsulated HCI Events and sends them to the MCU.

Item	Description	
Operating code	0x10	
Parameters	HCI Event (variable bytes)	Fully formatted HCI Event

Table 5-101. Encapsulated HCI Event

## 5.14 ANCS Events: HCI\_CONTROL\_GROUP\_ANCS

The Apple Notification Control Service (ANCS) events pertain to the ANCS commands that let an MCU perform various ANCS-related procedures using the CYW207xx. Refer to the Apple ANCS Specification [3] for more information.

### 5.14.1 ANCS Notification

An application running on a CYW207xx sends this event to an MCU when it receives a notification from a connected iOS device.

Item	Description	
Operating code	0x01	
Parameters	Notification UID (4 bytes)	Notification Unique Identifier
	Event ID (1 byte)	0: Notification added 1: Notification modified 2: Notification removed
	Category (1 bytes)	0: Other 1: Incoming call 2: Missed call 3: Voicemail 4: Social 5: Schedule 6: Email 7: News 8: Health and fitness 9: Business and finance 10: Location 11: Entertainment
	Flags (1 byte)	Bit mask of event flags Bit 0: Silent Bit 2: Important Bit 3: Preexisting Bit 4: Positive action possible Bit 5: Negative action possible



Item	Description	
Parameters	Title (variable bytes)	Zero terminated UTF8 string with notification title.
	Message (variable bytes)	Zero terminated UTF8 string with notification message.
	Positive Action (variable bytes)	Zero terminated UTF8 string with positive action that can be performed by the MCU.
	Negative Action (variable bytes)	Zero terminated UTF8 string with negative action that can be performed by the MCU.

Table 5-102. ANCS Notification Event

### 5.14.2 ANCS Command Status

This event indicates to the MCU that ANCS command execution has started or that a command has been rejected due to the state of the application.

Item	Description	
Operating code	0x02	
Parameters	Status (1 byte)	See <a href="#">"Command Status Event"</a> .

Table 5-103. ANCS Command Status Event

### 5.14.3 ANCS Service Found

This event indicates to the MCU that the ANCS service has been found on the given LE Connection Handle.

Item	Description	
Operating code	0x03	
Parameters	Connection Handle (2 bytes)	The connection handle reported in the LE Connected event.

Table 5-104. ANCS Service Found Event

### 5.14.4 ANCS Connected

This event indicates to the MCU that ANCS service has started. The MCU can expect to start receiving ANCS Notification events after the ANCS Connected event has occurred.

Item	Description	
Operating code	0x04	
Parameters	Connection Handle (2 bytes)	The connection handle reported in the LE Connected event.
	Result (1 byte)	Provides additional status information, see <a href="#">"Command Status Event"</a>

Table 5-105. ANCS Connected Event

### 5.14.5 ANCS Disconnected

This event indicates to the MCU that ANCS service has stopped or has been unsubscribed to. ANCS Notification events shall not occur after the ANCS service has been disconnected.

Item	Description	
Operating code	0x05	
Parameters	Connection Handle (2 bytes)	The connection handle reported in the LE Connected event.
	Result (1 byte)	Provides additional status information, see <a href="#">"Command Status Event"</a>

Table 5-106. ANCS Disconnected Event

## 5.15 AMS Events: HCI\_CONTROL\_GROUP\_AMS

The Apple Media Service (AMS) events pertain to the AMS commands that let an MCU perform various AMS-related procedures using the CYW207xx. Refer to the Apple developer AMS Specification [4] for more information:

### 5.15.1 AMS Command Status

This event indicates to the MCU that AMS command execution has started or that a command has been rejected due to the state of the application.

Item	Description	
Operating code	0x01	
Parameters	Status (1 byte)	See <a href="#">"Command Status Event"</a>

Table 5-107. AMS Command Status Event

### 5.15.2 AMS Service Found

This event indicates to the MCU that the AMS service has been found on the given LE Connection Handle.

Item	Description	
Operating code	0x02	
Parameters	Connection Handle (2 bytes)	The connection handle reported in the LE Connected event.

Table 5-108. AMS Service Found Event

### 5.15.3 AMS Connected

This event indicates to the MCU that AMS service has started.

Item	Description	
Operating code	0x03	
Parameters	Connection Handle (2 bytes)	The connection handle reported in the LE Connected event.
	Status (1 byte)	See <a href="#">"Command Status Event"</a>

Table 5-109. AMS Connected Event

### 5.15.4 AMS Disconnected

This event indicates to the MCU that AMS service has stopped or has been unsubscribed to.

Item	Description	
Operating code	0x04	
Parameters	Connection Handle (2 bytes)	The connection handle reported in the LE Connected event.
	Status (1 byte)	See <a href="#">"Command Status Event"</a>

Table 5-110. AMS Disconnected Event

## 5.16 Alert Events: HCI\_CONTROL\_GROUP\_ALERT

### 5.16.1 Alert Notification

An application running on a CYW207xx forwards alerts received from a peer device in this event.

Item	Description	
Operating code	0x01	
Parameters	Alert level (1 byte)	Alert level requested by the peer device. 0: No alert 1: Medium alert 2: High alert.

Table 5-111. Alert Notification Event

## 5.17 iAP2 Events: HCI\_CONTROL\_GROUP\_IAP2

The CYW207xx uses Apple iPod Accessory Protocol (iAP2) events to provide an MCU with protocol status changes and data received over an iAP2 External Accessory (EA) session.

### 5.17.1 IAP2 Connected

This event is sent when an EA session has been established with a peer device. The Bluetooth device address and connection handle are passed as parameters. The connection handle can be used by the MCU when sending subsequent commands or data and for identifying a peer device that has sent data.

This event can be sent for a connection originated by the MCU or by a peer iOS device.

Item	Description	
Operating code	0x01	
Parameters	bd_addr (6 bytes)	Bluetooth device address of the peer device with which an EA session has been established.
	Handle (2 bytes)	iAP2 EA session handle.

Table 5-112. IAP2 Connected Event

### 5.17.2 IAP2 Service Not Found

A CYW207xx sends this event when it is able to connect to a peer device and perform SDP discovery, but the iAP2 service is not found.

Item	Description
Operating code	0x02
Parameters	-

Table 5-113. IAP2 Service Not Found Event

### 5.17.3 IAP2 Connection Failed

The CYW207xx sends this event when a connection attempt requested by the MCU is unsuccessful.

Item	Description
Operating code	0x03
Parameters	-

Table 5-114. IAP2 Connection Failed Event

### 5.17.4 IAP2 Disconnected

This event is sent when a previously established EA session is disconnected.

Item	Description	
Operating code	0x04	
Parameters	Connection handle (2 bytes)	Connection handle reported in an IAP2 Connected event.

Table 5-115. IAP2 Disconnected Event

### 5.17.5 IAP2 TX Complete

A CYW207xx sends this event after a data packet received from an MCU in an IAP2 Send Data command has been queued for transmission. After sending the IAP2 Send Data command, an MCU should not send another data packet until it has received this event.

Item	Description	
Operating code	0x05	
Parameters	Connection handle (2 bytes)	Connection handle reported in an IAP2 Connected event.

Table 5-116. IAP2 TX Complete Event

### 5.17.6 IAP2 RX Data

A CYW207xx sends this event to forward iAP2 data received from a peer device during an EA session.

Item	Description	
Operating code	0x06	
Parameters	Connection handle (2 bytes)	Connection handle reported in an IAP2 Connected event.
	Data (variable bytes)	Data received from a peer.

Table 5-117. IAP2 RX Data Event

### 5.17.7 IAP2 Auth Chip Info

The CYW207xx sends this event after successfully processing an IAP2 Get Auth Chip Info command with chip information received from the authentication coprocessor.

Item	Description	
Operating code	0x07	
Parameters	Device version (1 byte)	Device version reported by the auth chip
	Firmware version (1 byte)	Firmware version reported by the auth chip
	Protocol version (Major) (1 byte)	Protocol version reported by the auth chip
	Protocol version (Minor) (1 byte)	Protocol version reported by the auth chip
	Device ID (4 bytes)	Device identification reported by the auth chip

Table 5-117. IAP2 Auth Chip Info Event

### 5.17.8 IAP2 Auth Chip Certificate

The CYW207xx sends this event after successfully receiving IAP2 Auth Chip Certificate.

Item	Description	
Operating code	0x08	
Parameters	Data (variable byte)	Auth chip certificate

Table 5-118. IAP2 Auth Chip Info Event

### 5.17.9 IAP2 Auth Chip Signature

The CYW207xx sends this event after successfully receiving IAP2 Auth Chip Signature.

Item	Description	
Operating code	0x09	
Parameters	Data (variable byte)	Auth chip signature

Table 5-119. IAP2 Auth Chip Info Event

## 5.18 AG Events: HCI\_CONTROL\_GROUP\_AG

These events sent by the CYW207xx pertain to the functionality of the hands-free profile audio gateway.

### 5.18.1 AG Open

This event is sent when an RFCOMM connection is established with a hands-free device. At this point, the Service Level Connection (SLC) is still not established, so commands cannot yet be sent. The Bluetooth device address and connection handle are passed as parameters. The connection handle can be used by the MCU to send commands or to identify a peer device that caused the event.

Item	Description	
Operating code	0x01	
Parameters	Connection handle (2 bytes)	Connection handle reported in an AG Connected event.
	Address (6 bytes)	Bluetooth device address of the AG.
	Status (1 byte)	-

Table 5-120. AG Open Event

### 5.18.2 AG Close

This event is sent when an RFCOMM connection with a hands-free device is closed.

Item	Description	
Operating code	0x02	
Parameters	Connection handle (2 bytes)	Connection handle reported in an AG Connected event.

Table 5-121. AG Close Event

### 5.18.3 AG Connected

This event is sent when the hands-free device and the AG have completed the protocol exchange necessary to establish an SLC. At this point, the application can send a command to establish an audio connection to the CYW207xx.

Item	Description	
Operating code	0x03	
Parameters	Connection handle (2 bytes)	Connection handle reported in an AG Connected event.
	Mask (4 bytes)	Mask of hands-free supported features.

Table 5-122. AG Connected Event

### 5.18.4 AG Audio Open

This event is sent when an audio connection with a hands-free device is opened.

Item	Description	
Operating code	0x04	
Parameters	Connection handle (2 bytes)	Connection handle reported in an AG Connected event.

Table 5-123. AG Audio Open Event

### 5.18.5 AG Audio Close

This event is sent when an audio connection with a hands-free device is closed.

Item	Description	
Operating code	0x05	
Parameters	Connection handle (2 bytes)	Connection handle reported in an AG Connected event.

Table 5-124. AG Audio Close Event

## 5.19 Audio Sink Events: HCI\_CONTROL\_GROUP\_AUDIO\_SINK

These events sent by the CYW207xx pertain to audio (A2DP) profile functionality.

### 5.19.1 Audio Sink Command Status

This event indicates to the MCU that an Audio Sink command execution has started or that a command has been rejected due to the state of the hci\_control application.

Item	Description	
Operating code	0x01	
Parameters	Status (1 byte)	
	See "Command Status Event".	

Table 5-125 Audio Sink Command Status Event

### 5.19.2 Audio Sink Connected

This event is sent when an audio sink connection has been established with a peer device. The Bluetooth device address and connection handle are passed as parameters. The connection handle can be used by the MCU to send commands or data, and to identify a peer device that has sent data.

Item	Description	
Operating code	0x02	
Parameters	Address (6 bytes)	Bluetooth device address of peer.
	Connection handle (2 bytes)	The handle to use during command and data exchanges.

Table 5-126 Audio Sink Connected Event

### 5.19.3 Audio Sink Service Not Found

A CYW207xx sends this event when it can connect to a peer device and perform SDP discovery, but there is no A2DP service.

Item	Description
Operating code	0x03
Parameters	-

Table 5-127 Audio Sink Service Not Found Event

### 5.19.4 Audio Sink Connection Failed

A CYW207xx sends this event when a connection attempt requested by the MCU is unsuccessful.

Item	Description
Operating code	0x04
Parameters	-

Table 5-128 Audio Sink Connection Failed Event

### 5.19.5 Audio Sink Disconnected

A CYW207xx sends this event when an audio sink connection has been dropped.

Item	Description
Operating code	0x05
Parameters	Connection handle (2 bytes)

Table 5-129 Audio Sink Disconnected Event

### 5.19.6 Audio Sink Started

A CYW207xx sends this event when an audio stream has been started by an MCU-sent Audio Sink Start command (see [“Audio Sink Start”](#)) or accept Audio Start Streaming request sent by peer ( see [“Audio Sink Start Response”](#)).

Item	Description
Operating code	0x06
Parameters	Connection handle (2 bytes)

Table 5-130 Audio Sink Started Event

### 5.19.7 Audio Sink Stopped

A CYW207xx sends this event when an audio stream has been stopped by an MCU-sent Audio Stop command (see [“Audio Sink Stop”](#)) or peer remote device stop audio streaming.

Item	Description
Operating code	0x07
Parameters	Connection handle (2 bytes)

Table 5-131 Audio Sink Stopped Event



### 5.19.8 Audio Sink Codec Configured

A CYW207xx sends this event when it receives AVDT SETCONFIG or AVDT RECONFIG command from peer audio source device in stream configuration process. On receiving this command MCU can configure the codec setting based on the received parameter.

Item	Description	
Operating code	0x08	
Parameters	Codec Id (1 byte)	0: SBC 1: MPEG-1, 2 2: MPEG-2, 4 0xFF: Vendor Specific
	Sampling Frequency (1 byte)	0x80: 16kHz 0x40: 32kHz 0x20: 44.1kHz 0x10: 48kHz
	Channel Mode (1 byte)	0x08: Mono 0x04: Dual 0x02: Stereo 0x01: Joint Stereo
	Block Length (1 byte)	0x80: 4 blocks 0x40: 8 blocks 0x20: 12 blocks 0x10: 16 blocks
	No of Sub bands (1 byte)	0x08: 4 0x04: 8
	Allocation Method (1 byte)	0x02: SNR 0x01: Loudness
	Max Bit pool (1 byte)	
	Min Bit pool (1 byte)	

Table 5-132 Audio Sink Codec Configured Event

### 5.19.9 Audio Sink Start Indication

This event is sent to the MCU on receiving an audio sink start request from the audio source device. The MCU shall use the [Audio Sink Start Response](#) command to accept/reject the audio stream start request.

Item	Description
Operating code	0x09
Parameters	Connection handle (2 bytes)
	Label (1 bytes)

Table 5-133 Audio Sink Start Indication

### 5.19.10 Audio Sink Data

This event is sent to the MCU on receiving audio steaming data from the audio source, when audio route is not I2S. Data can be encoded or decoded based on the audio route is selected. ( See ["Audio Sink Change Route"](#))

Item	Description
Operating code	0x0A
Parameters	Data (Variable length)

*Table 5-134 Audio Sink Data Event*

## 5.20 Miscellaneous Events: HCI\_CONTROL\_GROUP\_MISC

These events sent by the CYW207xx pertain to miscellaneous group of commands.

### 5.20.1 Ping Request Reply

This miscellaneous event is sent when the host sends a Ping Request (see “[Ping Request](#)”). The CYW207xx device responds with the exact data received in the Ping Request.

Item	Description
Operating code	0x01
Parameters	Data (variable bytes)

Table 5-135. Ping Request Reply Event

### 5.20.2 Version Info

The Version Info miscellaneous event is sent in reply to the MCU sending Get Version command (see “[Get Version](#)”).

Item	Description
Operating code	0x02
Parameters	Major version (1 byte)
	Minor version (1 byte)
	Revision number (1 byte)
	Build number (2 bytes)
	Chip ID (3 bytes)
	Power class (1 byte)

Table 5-136. Version Info Event

An application that runs on a CYW207xx with power class 1 and built using WICED Studio 1.0.1.188 should report 0x01, 0x00, 01, 0xBC, 0x00, 0xE2, 0x50, 0x00, 0x01.

## References

Document (or Item) Name	Number	Source
[1] CYW20706 WICED Kit Guide	002-18191	<a href="http://community.cypress.com">community.cypress.com</a>
[2] Bluetooth Core Specification, Version 4.2	–	<a href="http://www.bluetooth.org">www.bluetooth.org</a>
[3] Apple ANCS Specification	–	<a href="https://developer.apple.com/library/ios/documentation/CoreBluetooth/Reference/AppleNotificationCenterServiceSpecification/Specification/Specification.html">https://developer.apple.com/library/ios/documentation/CoreBluetooth/Reference/AppleNotificationCenterServiceSpecification/Specification/Specification.html</a>
[4] Apple AMS Specification	–	<a href="https://developer.apple.com/library/ios/documentation/CoreBluetooth/Reference/AppleMediaService_Reference/Specification/Specification.html">https://developer.apple.com/library/ios/documentation/CoreBluetooth/Reference/AppleMediaService_Reference/Specification/Specification.html</a>

## Document Revision History

Document Title: WICED HCI UART Control Protocol

Document Number: 002-16618

Revision	ECN	Issue Date	Description of Change
**	5659736	03/24/2017	Initial release in Cypress template, updates for current WICED Studio, download sections expanded.
*A	5856177	08/17/2017	Updated board names referenced in the document

# Worldwide Sales and Design Support

Cypress maintains a worldwide network of offices, solution centers, manufacturer's representatives, and distributors. To find the office closest to you, visit us at [Cypress Locations](#).

## Products

ARM® Cortex® Microcontrollers	<a href="http://cypress.com/arm">cypress.com/arm</a>
Automotive	<a href="http://cypress.com/automotive">cypress.com/automotive</a>
Clocks & Buffers	<a href="http://cypress.com/clocks">cypress.com/clocks</a>
Interface	<a href="http://cypress.com/interface">cypress.com/interface</a>
Internet of Things	<a href="http://cypress.com/iot">cypress.com/iot</a>
Memory	<a href="http://cypress.com/memory">cypress.com/memory</a>
Microcontrollers	<a href="http://cypress.com/mcu">cypress.com/mcu</a>
PSoC	<a href="http://cypress.com/psoc">cypress.com/psoc</a>
Power Management ICs	<a href="http://cypress.com/pmic">cypress.com/pmic</a>
Touch Sensing	<a href="http://cypress.com/touch">cypress.com/touch</a>
USB Controllers	<a href="http://cypress.com/usb">cypress.com/usb</a>
Wireless Connectivity	<a href="http://cypress.com/wireless">cypress.com/wireless</a>

## PSoC® Solutions

[PSoC 1](#) | [PSoC 3](#) | [PSoC 4](#) | [PSoC 5LP](#) | [PSoC 6](#)

## Cypress Developer Community

[Forums](#) | [WICED IOT Forums](#) | [Projects](#) | [Videos](#) | [Blogs](#)  
| [Training](#) | [Components](#)

## Technical Support

[cypress.com/support](http://cypress.com/support)



Cypress Semiconductor  
198 Champion Court  
San Jose, CA 95134-1709

© Cypress Semiconductor Corporation, 2017. This document is the property of Cypress Semiconductor Corporation and its subsidiaries, including Spansion LLC ("Cypress"). This document, including any software or firmware included or referenced in this document ("Software"), is owned by Cypress under the intellectual property laws and treaties of the United States and other countries worldwide. Cypress reserves all rights under such laws and treaties and does not, except as specifically stated in this paragraph, grant any license under its patents, copyrights, trademarks, or other intellectual property rights. If the Software is not accompanied by a license agreement and you do not otherwise have a written agreement with Cypress governing the use of the Software, then Cypress hereby grants you a personal, non-exclusive, nontransferable license (without the right to sublicense) (1) under its copyright rights in the Software (a) for Software provided in source code form, to modify and reproduce the Software solely for use with Cypress hardware products, only internally within your organization, and (b) to distribute the Software in binary code form externally to end users (either directly or indirectly through resellers and distributors), solely for use on Cypress hardware product units, and (2) under those claims of Cypress's patents that are infringed by the Software (as provided by Cypress, unmodified) to make, use, distribute, and import the Software solely for use with Cypress hardware products. Any other use, reproduction, modification, translation, or compilation of the Software is prohibited.

TO THE EXTENT PERMITTED BY APPLICABLE LAW, CYPRESS MAKES NO WARRANTY OF ANY KIND, EXPRESS OR IMPLIED, WITH REGARD TO THIS DOCUMENT OR ANY SOFTWARE OR ACCOMPANYING HARDWARE, INCLUDING, BUT NOT LIMITED TO, THE IMPLIED WARRANTIES OF MERCHANTABILITY AND FITNESS FOR A PARTICULAR PURPOSE. To the extent permitted by applicable law, Cypress reserves the right to make changes to this document without further notice. Cypress does not assume any liability arising out of the application or use of any product or circuit described in this document. Any information provided in this document, including any sample design information or programming code, is provided only for reference purposes. It is the responsibility of the user of this document to properly design, program, and test the functionality and safety of any application made of this information and any resulting product. Cypress products are not designed, intended, or authorized for use as critical components in systems designed or intended for the operation of weapons, weapons systems, nuclear installations, life-support devices or systems, other medical devices or systems (including resuscitation equipment and surgical implants), pollution control or hazardous substances management, or other uses where the failure of the device or system could cause personal injury, death, or property damage ("Unintended Uses"). A critical component is any component of a device or system whose failure to perform can be reasonably expected to cause the failure of the device or system, or to affect its safety or effectiveness. Cypress is not liable, in whole or in part, and you shall and hereby do release Cypress from any claim, damage, or other liability arising from or related to all Unintended Uses of Cypress products. You shall indemnify and hold Cypress harmless from and against all claims, costs, damages, and other liabilities, including claims for personal injury or death, arising from or related to any Unintended Uses of Cypress products.

Cypress, the Cypress logo, Spansion, the Spansion logo, and combinations thereof, WICED, PSoC, CapSense, EZ-USB, F-RAM, and Traveo are trademarks or registered trademarks of Cypress in the United States and other countries. For a more complete list of Cypress trademarks, visit [cypress.com](http://cypress.com). Other names and brands may be claimed as property of their respective owners.