



PSoC1 3-Opamp INSAMP

Project Name: Example_INSAMP

Programming Language: C

Associated Part Families: CY8C24x23, CY8C27x43, CY8C29x66
CY8C24x94, CY8C21x34

Software Version: PSoC[®] 1 Designer™ 5.2

Related Hardware : CY3210 PSoCEval1 Board

Project Objective

This project demonstrates the operation of INSAMP user module with three Opamp topology of the PSoC[®] 1 device.

Overview

In this project, a differential signal is applied at the input of an instrumentation amplifier. Both the amplified signal and the common mode output voltage are routed to analog output pins. The output of the INSAMP is also fed to an ADC and the measure voltage is displayed on an LCD.

User Module List and Placement

The following table lists the user modules used in this project and the hardware resources occupied by each user module.

User Module	Placement
INSAMP	ACB00 (Non inverting input) ACB01 (Inverting input) ASD11 (Conversion amplifier)
ADCINCVR	ASC21 (Integrator) DBB00 (Counter) DBB01 (PWM16_LSB) DCB02 (PWM16_MSB)
LCD	P2[0] to P2[6]
RefMux	ACB02

User Module Parameter Settings

The following tables show the user module parameter settings for each of the user modules used in the project.

INSAMP		
Parameter	Value	Comments
AnalogBus	AnalogOutBus_1	Output of instrumentation amplifier is routed to analog output buffer 1.
CommonModeOut	Via NON_INV Block	The common mode signal is brought out using the Non Inverting block on Analog Column 0 and through the Analog output buffer to P0[3]
DifferentialGain	2.000	See Note
Conversion Gain	1.000	See Note

Note

The overall gain of the instrumentation amplifier is the product of differential gain and conversion gain. The differential gain is set by resistive dividers in the CT blocks and the Conversion gain is set by the ratio of input and feedback capacitors in the SC block. In this project the overall gain of the instrumentation amplifier is 2.000.

The CommonModeOut signal provides the common mode voltage of the differential input signal and can be routed to an external pin. In practical applications, this signal can be used to improve the noise immunity of a system by connecting to a shield around the +ve and -ve input signals.

The three OpAmp topology INSAMP uses an SC block for the Conversion Gain section. The analog column clock for the column that has the SC block should not exceed the maximum column clock specification. Refer the user module data sheet for the maximum column clock value for various analog powers. In this project, the column clock for the INSAMP is set to VC2 which is 1 MHz.

ADCINCVR		
Parameter	Value	Comments
Input	AnalogOutBus_1	Output of instrumentation amplifier is routed to the input of ADCINCVR through the analog output buffer1.
Clock_Phase	Norm	Phi1 > Acquire charge Phi2 > Transfer charge
Clock	VC2	Column clock for ADCINCVR is 1 MHz.
ADC Resolution	13 Bit	Sampled data is represented using 13 bits.
Calc Time	45	Time taken for CPU to calculate intermediate integration result is 45 data clock.
Data Format	Signed	12 bits are used to represent magnitude and one bit is used to represent sign.

Notes

- The Clock phase parameter is set to be the opposite of the clock phase of the SCBLOCK, which sources the data. In the default configuration of INSAMP, SCBLOCK uses the clock phase as "Normal". So, the ADC's clock phase is set to "Swap". More details on the clock phase can be found in the below article.

[PSoC 1 ADCs – The Five Golden Rules](#)

- CalcTime is calculated using the data clock and the resolution of the ADC. Refer to the UM data sheet for the formula and calculations.
- The column clock to the ADCINCVR should be same as the data clock. In this case, the column clock to Analog Column 2 should be set to VC2. More details on this can be found in the same article, PSoC 1 ADCs – The Five Golden Rules.

RefMux		
Parameter	Value	Comments
Reference Select	AGND	AGND is routed to P0[4] through analog output buffer2.

Note: The ReMux is used to bring out the internal Analog Ground to P0[4]. The AGND is used as the -ve input for the INSAMP.

LCD		
Parameter	Value	Comments
LCDPort	Port_2	Port 2 is used to send data to LCD
BarGraph	Disable	Bar graph is not used in this project

Global Resources

Important Global Resources		
Parameter	Value	Comments
CPU Clock	SysClk/2	Sets the CPU frequency to 12 MHz.
VC1	12	Divide 24 MHz system clock by 12 to get 2 MHz clock.
VC2	2	Divide VC1 clock by 2 to get 1 MHz clock, which is given as column clock for ADCINCVR user module.
Analog Power	SC On/Ref High	Set the maximum operating power of analog blocks to Ref High.
Ref Mux	$(V_{dd}/2) \pm (V_{dd}/2)$	Ref High = 5 V Ref Low = 0 V AGND = 2.5 V

All other global resources are left at the default value because they are not specific to this project.

Pin Configuration

Pin Out			
Pin	Select	Drive	Direction
Port 0_1	Analog input	High Z analog	Input
Port 0_2	Analog input	High Z analog	Input
Port 0_5	AnalogOutBuf_1	High Z analog	Output
Port 0_4	AnalogOutBuf_2	High Z analog	Output
Port2_0-Port2_6	StdCPU	Strong	Output

Hardware Connections

The following figure shows the schematic of the project.

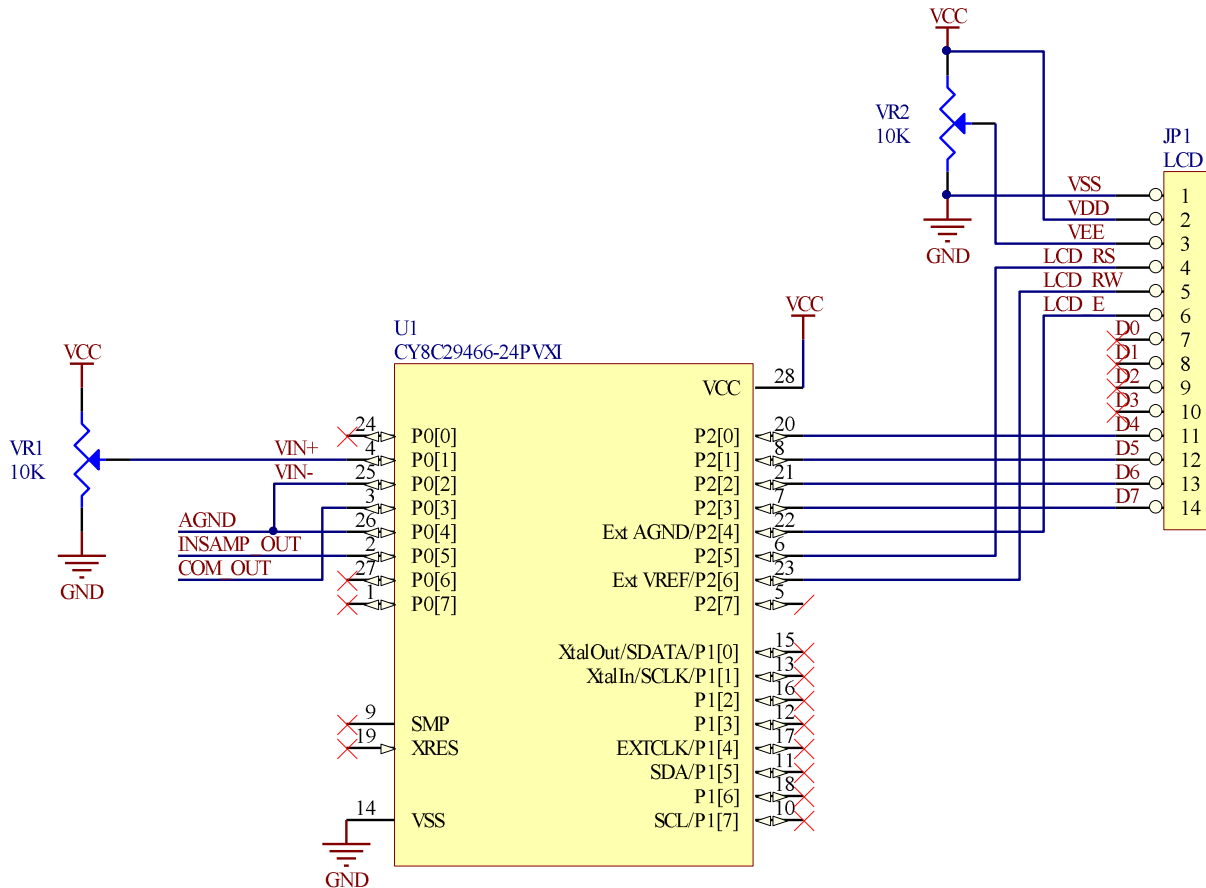

P0[1] is the +ve input and P0[2] is the –ve input to the INSAMP. AGND is brought out on P0[4] and is tied to the –ve input of the INSAMP. The +ve input to the INSAMP comes from potentiometer VR1. The analog output of the INSAMP is available on P0[5]. The common mode output of the INSAMP is available on P0[3]. In practical applications, the common mode signal is used to increase the noise immunity of the system by creating a guard trace around the +ve and –ve input signals and connecting this guard trace to the common mode voltage.

The project can be tested using CY3210 – PSoC Eval1 board. To test the project, make the following connections:

- Connect P0[1] of J6 to VR of J5. This is the +ve input to the INSAMP
- Connect P0[2] of J6 to P0[4] of J6. This is the –ve input to the INSAMP
- Connect LCD module to J9 header
- Connect a voltmeter between P0[5] and P0[4] of J6 header to measure the output of INSAMP
- The Common mode voltage output may be measured on P0[3] of J6

Operation

On program execution, all hardware settings from the device configuration are loaded into the device and *main.c* is executed.

The following operations are performed inside *main.c*.

1. Enable global interrupts.
2. Start RefMux user module.
3. Start instrumentation amplifier in high power mode. The instrumentation amplifier becomes operational at this point and needs no more CPU intervention. All the code that follows is to convert the INSAMP output to digital value and display on the LCD.
4. Start incremental ADC in high power mode.
5. Start LCD.
6. Run the ADCINCVR in continuous sampling mode.
7. Wait for the ADCINCVR output data to be ready. If ADCINCVR output data is available, go to step 8. Else go to step 7.
8. Get the converted data from ADCINCVR and clear the status flag.
9. Multiply ADCINCVR output data by step size of analog to digital conversion. (Step size is calculated by the user and the calculated value is defined as macro using #define directive in the top of *main.c*.
Step size = $(\text{RefHigh} - \text{RefLow}) / (2^{\text{Resolution}})$).
10. Make the cursor position on LCD as row 0 column 0.
11. Display the String "INSAMP OUTPUT" on LCD.
12. Make the cursor position on LCD as row 1 column 0.
13. Clear previously displayed value on LCD.
14. Make the cursor position on LCD as row 1 column 0.
15. Convert the float value obtained from step 9 to ASCII using ftoa() function and display the string returned by the ftoa() function on LCD.
16. Display the character "V" on the LCD in current cursor position.
17. Go to step 7.

Testing the Project

To test the project using CY3210 PSoCEval1 board, follow these steps:

Make the connections as shown in the Hardware connections section.

Vary the position of potentiometer to change the input to the INSAMP. Measure the input voltage between P0[1] and P0[2] and the output voltage between P0[4] and P0[5]. The output voltage should be $(2 * \text{Input voltage})$. At the same time, the output voltage is displayed on the LCD.

For example, if the differential signal input between P0[1] and P0[2] is 1 V, then the output of instrumentation amplifier between P0[4] and P0[5] is approximately 2 V and the LCD displays the voltage.

INSAMP OUTPUT

2.0458327 V

Experiment with different values of Differential and Conversion gains and verify that the INSAMP is operating correctly.

PSoC is a registered trademark and PSoC Designer is a trademark of Cypress Semiconductor Corporation. All other trademarks or registered trademarks referenced herein are the property of their respective owners.

Cypress Semiconductor
198 Champion Court
San Jose, CA 95134-1709
Phone: 408-943-2600
Fax: 408-943-4730
<http://www.cypress.com/>

© Cypress Semiconductor Corporation, 2009-2011. The information contained herein is subject to change without notice. Cypress Semiconductor Corporation assumes no responsibility for the use of any circuitry other than circuitry embodied in a Cypress product. Nor does it convey or imply any license under patent or other rights. Cypress products are not warranted nor intended to be used for medical, life support, life saving, critical control or safety applications, unless pursuant to an express written agreement with Cypress. Furthermore, Cypress does not authorize its products for use as critical components in life-support systems where a malfunction or failure may reasonably be expected to result in significant injury to the user. The inclusion of Cypress products in life-support systems application implies that the manufacturer assumes all risk of such use and in doing so indemnifies Cypress against all charges. This Source Code (software and/or firmware) is owned by Cypress Semiconductor Corporation (Cypress) and is protected by and subject to worldwide patent protection (United States and foreign), United States copyright laws and international treaty provisions. Cypress hereby grants to licensee a personal, non-exclusive, non-transferable license to copy, use, modify, create derivative works of, and compile the Cypress Source Code and derivative works for the sole purpose of creating custom software and or firmware in support of licensee product to be used only in conjunction with a Cypress integrated circuit as specified in the applicable agreement. Any reproduction, modification, translation, compilation, or representation of this Source Code except as specified above is prohibited without the express written permission of Cypress.

Disclaimer: CYPRESS MAKES NO WARRANTY OF ANY KIND, EXPRESS OR IMPLIED, WITH REGARD TO THIS MATERIAL, INCLUDING, BUT NOT LIMITED TO, THE IMPLIED WARRANTIES OF MERCHANTABILITY AND FITNESS FOR A PARTICULAR PURPOSE. Cypress reserves the right to make changes without further notice to the materials described herein. Cypress does not assume any liability arising out of the application or use of any product or circuit described herein. Cypress does not authorize its products for use as critical components in life-support systems where a malfunction or failure may reasonably be expected to result in significant injury to the user. The inclusion of Cypress' product in a life-support systems application implies that the manufacturer assumes all risk of such use and in doing so indemnifies Cypress against all charges.

Use may be limited by and subject to the applicable Cypress software license agreement.