



## Converting STK25C48 to STK12C68

### Introduction

This document provides guidance on converting a design that is currently using the STK25C48 to the Simtek recommended part STK12C68

### Feature set and limitations of the STK25C48

Function Category	STK25C48	STK12C68
Autostore	Yes, by specified slow VCC fall rate	Wire for immunity from ramp rate using a 68uf capacitor
Software store	Yes	Yes
Software recall	Yes	Yes

### Package Comparison

The STK25C48 is only available in the 24 pin 600mil plastic dip package. The closest package is the 600 mil 28 pin PDIP and being larger may cause layout difficulty.

Package	PKC Code	STK25C48	STK12C68	Notes
350 mil SOIC – 28 pin	S	Not available	Available	Surface mount – smallest PCB area
600 mil pdip -- 28 pin	W	Available	Available	Through hole
300 mil cdip -- 28 pin	C	Not available	Available	Through hole
600 mil pdip -- 24pin	W	Not available	Available	Through hole

### Issues to consider during the conversion

The key difference is that the STK25C48 has been internally configured to autostore but does not use a 68uf capacitor. This means there is no protection from power that falls too fast. This is no longer a recommended application and is no longer supported by Simtek. The STK12C68 will be wired using the 68uf power storage capacitor on the VCAP pin. The converted STK12C68 application will then be fully immune from the minimum ramp rate requirement. This application will process an autostore using power stored on a 68uf capacitor. Also, the new HSB signal is unused. All other pins have the same function.

## Schematic changes for conversion:

This is a feature upgrade and conversion of the STK25C48 to the mainstream STK12C68. Applications requiring a minimum ramp rate are no longer supported or recommended. So, this conversion is to the full featured STK12C68 application with autostore being powered from a storage capacitor. This requires the addition of a 68uf capacitor and wired to VCAP pin 1. Also, the bypass capacitor moves to the VCAP pin. The choice of package is open with the “S” package being the most area efficient surface mount choice.

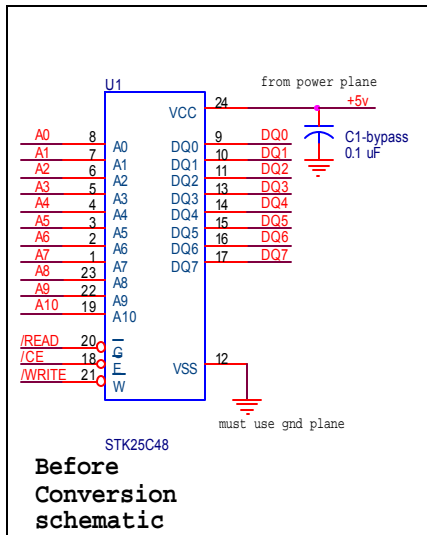

In this conversion, old bypass capacitor C1 is moved from +5v on pin 24 to pin 1. The storage capacitor C2 is added to pin 1 and system power is connected to pin 28. The 12C69 pins 23 and 2 (A11 and A12) are tied low or you may utilize the additional memory space: (if you expand the space, be sure to expand the memory space in the /E logic decoding). The new signal /HSB is left open and unused.

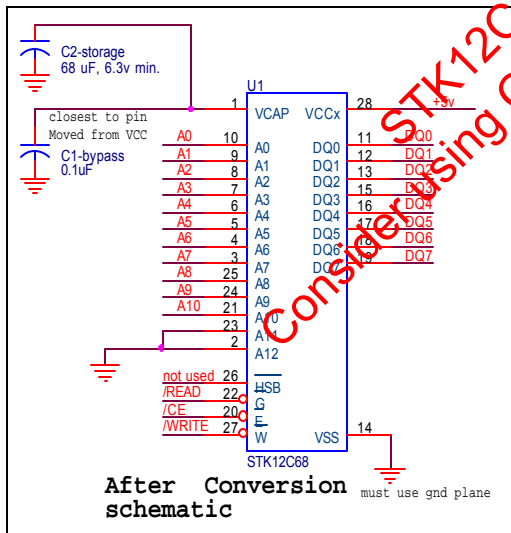

On the next page, pin by pin comparisons of the two show all pins are the same except for the bypass capacitor moving to pin 1 and connected to system power, +5v.

## Corresponding pin Connections

Pin for pin comparison of the two parts is given in the table below:

STK25C48 NAME	Pin	STK12C68 NAME	Pin	Comments
--none--		VCAP	1	Must connect 0.1UF BYPASS and 68uf, 6.3v min.
--none--		A12	2	Tie to gnd
A7	1	A7	3	No change
A6	2	A6	4	"
A5	3	A5	5	"
A4	4	A4	6	"
A3	5	A3	7	"
A2	6	A2	8	"
A1	7	A1	9	"
A0	8	A0	10	"
DQ0	9	DQ0	11	"
DQ1	10	DQ1	12	"
DQ2	11	DQ2	13	"
VSS	12	VSS	14	"
DQ3	13	DQ3	15	"
DQ4	14	DQ4	16	"
DQ5	15	DQ5	17	"
DQ6	16	DQ6	18	"
DQ7	17	DQ7	19	"
E#	18	E#	20	"
A10	19	A10	21	"
G#	20	G#	22	"
--none--		A11	23	Tie to gnd
A9	22	A9	24	No change
A8	23	A8	25	"
--none--		HSB	26	LEAVE OPEN UNUSED
W#	21	W#	27	No change
VCC	24	VCC	28	This pin now must continue to be connected to +5v, bypass of 0.1uF is ok but unneeded.

STK12C68 is in NRND Status.  
Consider using C144E256LA instead of STK12C68.